

DRAFT

**INITIAL STUDY/
MITIGATED NEGATIVE DECLARATION**

**VALLEY VIEW PARK PROJECT
CASTRO VALLEY, ALAMEDA COUNTY, CALIFORNIA**



LSA

April 2023

This page intentionally left blank

**INITIAL STUDY/
MITIGATED NEGATIVE DECLARATION**

**VALLEY VIEW PARK PROJECT
CASTRO VALLEY, ALAMEDA COUNTY, CALIFORNIA**

Submitted to:

Hayward Area Recreation and Park District
1099 E Street
Hayward, CA 94541

Prepared by:

LSA
157 Park Place
Pt. Richmond, California 94801
510.236.6810

Project No. WRT2102



April 2023

This page intentionally left blank

TABLE OF CONTENTS

1.0 PROJECT INFORMATION	1-1
2.0 PROJECT DESCRIPTION	2-1
2.1 PROJECT SITE	2-1
2.2 PROJECT BACKGROUND AND OBJECTIVES	2-6
2.3 PROPOSED PROJECT	2-8
2.4 PROJECT APPROVALS	2-24
3.0 ENVIRONMENTAL FACTORS POTENTIALLY AFFECTED.....	3-1
3.1 Determination	3-1
4.0 CEQA ENVIRONMENTAL CHECKLIST	4-1
4.1 Aesthetics	4-1
4.2 Agriculture and Forestry Resources	4-4
4.3 Air Quality	4-6
4.4 Biological Resources.....	4-15
4.5 Cultural Resources	4-43
4.6 Energy.....	4-47
4.7 Geology and Soils	4-50
4.8 Greenhouse Gas Emissions	4-56
4.9 Hazards and Hazardous Materials	4-61
4.10 Land Use and Planning	4-76
4.11 Mineral Resources.....	4-83
4.12 Noise.....	4-84
4.13 Population and Housing	4-98
4.14 Public Services.....	4-99
4.15 Recreation	4-102
4.16 Transportation	4-103
4.17 Tribal Cultural Resources	4-108
4.18 Utilities and Service Systems.....	4-111
4.19 Wildfire.....	4-116
4.20 Mandatory Findings of Significance	4-119
5.0 LIST OF PREPARERS	5-1
6.0 REFERENCES	6-1

APPENDICES

- A: CALEEMOD OUTPUT SHEETS
- B: TRAFFIC VOLUME DATA

FIGURES AND TABLES

FIGURES

Figure 1: Regional Location	2-3
Figure 2: Aerial Photograph of the Project Site and Surrounding Land Uses	2-4
Figure 3: Conceptual Site Plan	2-9
Figure 4: Site Detail - Active Uses	2-10
Figure 5: Site Detail – Passive Uses.....	2-13
Figure 6: Planting and Conserved Natural Vegetation	2-17
Figure 7: Site Engineering	2-21
Figure 8: Noise Monitoring Locations	4-89

TABLES

Table 2.A: Proposed Design Features of Valley View Park	2-7
Table 2.B: Potential Permits and Approvals	2-24
Table 4.A: Project Construction Emissions (in Pounds Per Day).....	4-10
Table 4.B: Project Operational Emissions	4-12
Table 4.C: Wildlife Species Observed During the Field Survey	4-18
Table 4.D: Special-Status Plant Species Evaluated for the Project	4-20
Table 4.E: Special-Status Wildlife Species Evaluated for the Proposed Project	4-27
Table 4.F: Estimated Annual Energy Use of Proposed Project	4-48
Table 4.G: Exterior Noise Level Standards – Sensitive Land Uses.....	4-85
Table 4.H: Detailed Assessment Construction Noise Criteria	4-86
Table 4.I: Interpretation of Vibration Criteria for Detailed Analysis.....	4-86
Table 4.J: Construction Vibration Damage Criteria.....	4-87
Table 4.K: Typical Construction Equipment Noise Levels	4-92
Table 4.L: Vibration Source Amplitudes for Construction Equipment.....	4-95
Table 4.M: Trip Generation Summary	4-104
Table 4.N: Roadway Traffic Volume.....	4-105
Table 4.O: Vehicle Level of Service Summary	4-105

LIST OF ABBREVIATIONS AND ACRONYMS

AB	Assembly Bill
AB 52	Assembly Bill 52
ABAG	Association of Bay Area Governments
ACCWP	Alameda Countywide Clean Water Program
ACDEH	Alameda County Department of Environmental Health
ACFD	Alameda County Fire Department
ACM	asbestos-containing material
APN	Assessor's Parcel Number
BAAQMD	Bay Area Air Quality Management District
Basin Plan	Water Quality Control Plan
bgs	below ground surface
BMP	Best Management Practices
CAIP	Corrective Action Implementation Plan
CalEEMod	California Emissions Estimator Model
California Register	California Register of Historical Resources
CAP	Corrective Action Plan
CBC	California Building Code
CCR	California Code of Regulations
CDFW	California Department of Fish and Wildlife
CEC	California Energy Commission
CEQA	California Environmental Quality Act
CGS	California Geological Survey
CH ₄	methane

Clean Air Plan	BAAQMD 2017 Clean Air Plan
CNEL	community noise equivalent level
CO	carbon monoxide
CO ₂	carbon dioxide
CO ₂ e	carbon dioxide equivalents
CoIWMP	Countywide Integrated Waste Management Plan
dB	decibel
dBA	A-weighted (sound level) decibels
DOSH	California Division of Occupational Safety and Health
DOT	U.S. Department of Transportation
EBCE	East Bay Community Energy
EBMUD	East Bay Municipal Utility District
Eden MAC	Eden Area Municipal Advisory Council
EFZ	Earthquake Fault Zones
EOC	Alameda County Emergency Operations Center
EOP	Alameda County Emergency Operations Plan
ESA	Phase I Environmental Site Assessment
ESL	Environmental Screening Level
FHWA	Federal Highway Administration
FTA	Federal Transit Administration
GHG	greenhouse gas
GP	General Permit
GWP	Global Warming Potential
HARD	Hayward Area Recreation and Park District

HFCs	hydrofluorocarbons
HSP	Health and Safety Plan
I-580	Interstate 580
in/sec	inches per second
IS/MND	Initial Study/Mitigated Negative Declaration
LBP	lead-based paint
L _{dn}	day-night average level
L _{eq}	equivalent continuous sound level
L _{max}	maximum instantaneous noise level
LUST	Leaking Underground Storage Tank
L _v	velocity in decibels
MDR	Medium Density Residential
mgd	million gallons per day
MLD	Most Likely Descendant
MMI	Modified Mercalli Intensity
mpg	miles per gallon
MRP	Regional Water Quality Control Board Municipal Regional Permit
MTBE	methyl tert-butyl ether
MTC	Metropolitan Transportation Commission
N ₂ O	nitrous oxide
NAHC	California Native American Heritage Commission
NO ₂	nitrogen dioxide
NO _x	nitrogen oxide
NPDES	National Pollutant Discharge Elimination System

NWIC	Northwest Information Center
OES	Alameda County Sheriff's Office of Emergency Services
OLSD	Oro Loma Sanitary District
OSHA	Occupational Health and Safety Administration
Pb	lead
PCB	polychlorinated biphenyl
PFCs	perfluorocarbons
PM ₁₀	respirable particulate matter
PM _{2.5}	fine particulate matter
POTW	publicly owned treatment works
PPV	peak particle velocity
PRC	Public Resources Code
RCRA	Federal Resource Conservation and Recovery Act
RMS	root-mean-square
ROG	reactive organic gases
RWQCB	San Francisco Bay Regional Water Quality Control Board
SBA	SBA Communications
SB	Senate Bill
SF ₆	sulfur hexafluoride
SO ₂	sulfur dioxide
State Water Board	State Water Resources Control Board
SWPPP	Storm Water Pollution Prevention Plan
TACs	toxic air contaminants
TPL	The Trust for Public Land

USDA	United States Department of Agriculture
UST	underground storage tank
VCA	Voluntary Cleanup Agreement
VdB	vibration velocity in decibels
VMT	vehicle miles traveled
WTP	water treatment plant

This page intentionally left blank

1.0 PROJECT INFORMATION

1. Project Title:

Valley View Park Project

2. Lead Agency Name and Address:

Hayward Area Recreation and Park District
1099 E Street
Hayward, CA 94541

3. Contact Person and Phone Number:

Darcie DeLashmutt, Project Bond Manager
510-750-4723

4. Project Location:

The project site is located within the unincorporated community of Castro Valley in Alameda County (County). The approximately 24-acre project site is located south of Lake Chabot Regional Park and is bound by residential uses and Sydney Way to the north, residential uses and Carlton Avenue to the east, residential uses and Stanton Avenue to the west, and residential uses and Jennifer Drive to the south.

The site consists of Assessor's Parcel Numbers (APNs): 84B-0425-006-01, 84B-0425-001-01, 84B-0425-001-11, 84B-0425-003, 84B-0425-012, 84B-0425-005-03, 84B-0441-032, 84B-0441-033, 84B-0441-034, 84B-0441-036, 84B-0420-004-05, 84B-0420-004-06, 84B-0420-005, 84B-0420-010-01, 84B-0420-011-01, 84B-0460-010, 84B-0460-012, 84B-0460-009-07, 84B-0460-011, 84B-0460-013, 84B-460-1, 84B-460-003, 84B-0455-005-05, 84B-455-5-5, 84B-0441-035, and portions of 84B-0415-007-07, 84B-0455-005-05, 84B-0415-007-07.

5. Project Sponsor's Name and Address:

Hayward Area Recreation and Park District
1099 E Street
Hayward, CA 94541

6. General Plan Designation:

Hillside Residential (RH) 4-8 dwelling units/acre
Open Space – Parks (OSP)

7. Zoning:

Single-Family Residential with conditional secondary unit (CSU) and recreational vehicle (RV) combining districts (R1-CSU-RV)
Open Space-Parks with CSU and RV combining districts (OSP-CSU-RV)
Planned Development with CSU and RV combining districts (PD-CSU-RV)

- 8. Description of Project:** The Hayward Area Recreation and Park District (HARD) proposes to develop a new community park in the unincorporated community of Castro Valley, Alameda County. The proposed Valley View Park Project (project) would provide recreation and gathering space for the surrounding neighborhoods and the greater community. Existing site conditions, project background, and individual components of the proposed project itself, are described in Section 2.0 Project Description.
- 9. Surrounding Land Uses and Setting:** The project site is surrounded by residential neighborhoods in western Castro Valley. Immediately north of the project site is Sydney Way and single-family residential uses, which extend north towards Lake Chabot Regional Park. The project site is bounded to the east by Carlton Avenue and single-family residential uses. Further east are additional residential uses and the Castro Valley Community Center. Jennifer Drive partially bounds the project site to the south. Additional residential uses are also located to the south of the project site. Stanton Elementary School and Eden Medical Center are located further south. Stanton Avenue and single-family residential uses bound the site to the west. Additional information on the surrounding land uses and setting are provided in Section 2.0, Project Description.

10. Other Public Agencies Whose Approval is Required (e.g., permits, financial approval, or participation agreements):

Public agencies whose approval would be required include, but are not limited to the following:

- Alameda County
- State Water Resources Control Board
- Bay Area Air Quality Management District
- Regional Water Quality Control Board

11. Have California Native American tribes traditionally and culturally affiliated with the project area requested consultation pursuant to Public Resource Code section 21080.3.1? If so, is there a plan for consultation that includes, for example, the determination of significance of impacts to tribal cultural resources, procedures regarding confidentiality, etc.?

On March 24, 2022, the Native American Heritage Commission (NAHC) provided a list of California Native American tribes and tribal representatives that may be culturally-affiliated with the project site. On January 24, 2023, HARD offered potentially interested tribal representatives the opportunity to consult on the proposed project. The letters, sent via certified mail to the tribal contacts, described the project, provided maps of the project site, and invited the tribes to request consultation should they have any concerns.

On February 24, 2023, Corrina Gould, Tribal Chair of the Confederated Villages of Lisjan Nation responded by email to request additional information regarding the project site and the results of the Sacred Lands File search. HARD responded via email on February 28, 2023 and followed up with a second email on April 20, 2023. To date, consultation is ongoing.

2.0 PROJECT DESCRIPTION

The following describes the proposed Valley View Park Project (project) that is the subject of this Initial Study/Mitigated Negative Declaration (IS/MND) prepared pursuant to the California Environmental Quality Act (CEQA). The proposed project is the development of a 24-acre undeveloped hilltop site to create a new community park in the unincorporated community of Castro Valley.

2.1 PROJECT SITE

The following describes the project location, existing conditions, surrounding land uses, and the regulatory setting.

2.1.1 Project Location

The project site is located within the unincorporated community of Castro Valley in Alameda County (County). The approximately 24-acre project site consists of Assessor's Parcel Numbers (APNs): 84B-0425-006-01, 84B-0425-001-01, 84B-0425-001-11, 84B-0425-003, 84B-0425-012, 84B-0425-005-03, 84B-0441-032, 84B-0441-033, 84B-0441-034, 84B-0441-036, 84B-0420-004-05, 84B-0420-004-06, 84B-0420-005, 84B-0420-010-01, 84B-0420-011-01, 84B-0460-010, 84B-0460-012, 84B-0460-009-07, 84B-0460-011, 84B-0460-013, 84B-460-1, 84B-460-003, 84B-0455-005-05, 84B-455-5-5, 84B-0441-035, and portions of 84B-0415-007-07, 84B-0455-005-05, 84B-0415-007-07.

The site is located south of Lake Chabot Regional Park and is bound by residential uses and Sydney Way to the north, residential uses and Carlton Avenue to the east, residential uses and Stanton Avenue to the west, and residential uses and Jennifer Drive to the south. The project's location and regional vicinity is shown in Figure 1 and an aerial of the project site and surrounding land uses are shown in Figure 2.

2.1.2 Existing Conditions

The project site is currently an undeveloped hilltop landscape surrounded by residential neighborhoods featuring views of Castro Valley including Lake Chabot and regional open spaces; the East Bay Hills including Mount Diablo; and the distant San Francisco Bay and Santa Cruz Mountains. The project site is not currently open for public access; however, residents do access the site and have created informal passive recreation features, including a tire swing and dirt paths used by bicyclists and pedestrians. Along most of its perimeter, the site is bordered by residential backyards. The perimeter of the site currently has a variety of fence types and some planting, primarily installed by adjacent neighborhoods, that provide varying degrees of security and privacy screening.

Topography of the project site varies considerably from generally level to 100 percent slopes in certain areas of the site. Slope failures have occurred on the western part of the site and rock outcropping are present on the southeast portion of the site, which may suggest topsoil depth is very limited.

The majority of the project site consists of a non-native annual grassland interspersed with groves of tree. Trees observed in the groves/forest include native coast live oak (*Quercus californicus*), Fremont cottonwood (*Populus fremontii*), and black walnut (*Juglans*

This page intentionally left blank

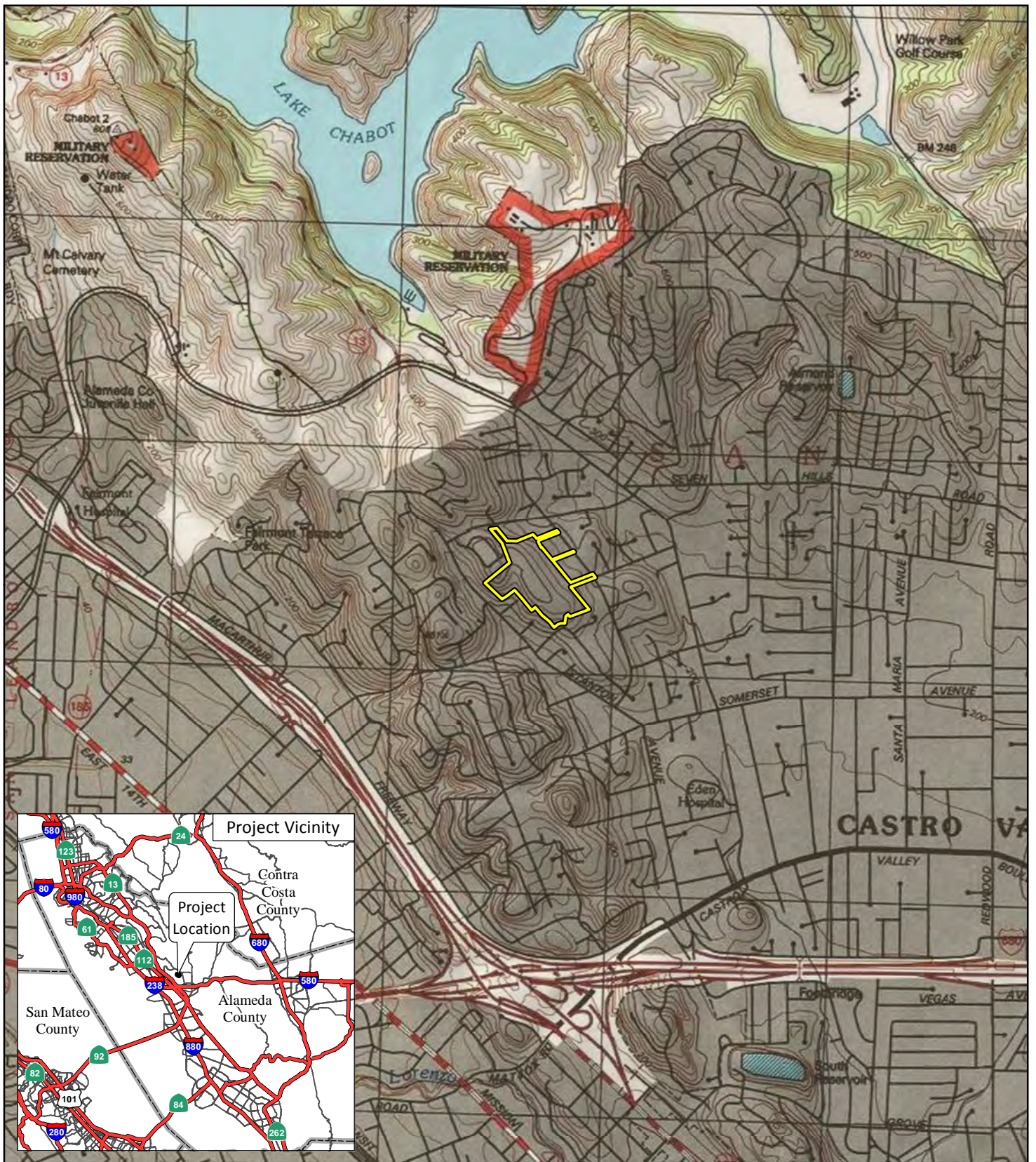
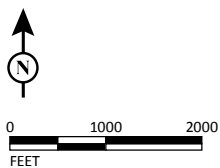

FIGURE 1

LSA

LEGEND
 Project Location



SOURCE: USGS 7.5' Quad - Hayward (1980), CA
 I:\WRT2102\GIS\MXD\ProjLoc_USGS.mxd (2/3/2022)



FIGURE 2

LSA

 Project Site Boundary

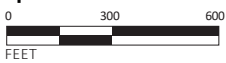

SOURCES: Google Earth, 8/5/2020; LSA, 2023

Valley View Park Master Plan Project
Aerial Photograph of the Project Site and Surrounding Land Uses

I:\WRT2102\g\Aerial Photo of Site & Surrounding LU.ai (1/9/2023)

hindsii) and non-native red ironbark (*Eucalyptus sideroxylon*), Coulter pine (*Pinus coulteri*), Torrey pine (*Pinus torreyana*), acacia (*Acacia* sp.), Italian cypress (*Cupressus sempervirens*), olive (*Olea europaea*), plum (*Prunus* spp.), and Peruvian pepper (*Schinus molle*). Developed portions of the project site include paved asphalt roads and remains of old building foundations. A former storm drain culvert that appears to be collapsed and not-functional is present near an asphalt road, but no wetland vegetation was observed at the bottom of the culvert.

2.1.2.1 Surrounding Land Uses

As shown in Figure 2, the project site is surrounded by residential neighborhoods in western Castro Valley. Immediately north of the project site is Sydney Way and single-family residential uses, which extend north towards Lake Chabot Regional Park. The project site is bounded to the east by Carlton Avenue and single-family residential uses. Further east are additional residential uses and the Castro Valley Community Center. Jennifer Drive partially bounds the project site to the south. Additional residential uses are also located to the south of the project site. Stanton Elementary School and Eden Medical Center are located further south. Stanton Avenue and single-family residential uses bound the site to the west.

2.1.3 Parking, Circulation, and Access

Pedestrian access to the site is provided from Carlton Avenue at three locations along Sydney Way, Stanton Avenue, and Jennifer Drive. On-street parking is also provided along these access roads. Pedestrian access throughout the project site is provided by trails and pathways.

The site is a 5-minute walk (approximately 0.5-mile) from the Castro Valley Community Center to the east, a 10-minute walk (approximately 0.5-mile) from Stanton Elementary School to the south, and a 10-minute walk (approximately 0.7-mile) to Lake Chabot Regional Park to the north. Sidewalks and crosswalks are missing on most segments of these street connections and fast-moving traffic, limited sightlines due to topography, and informal parking result in safety challenges in pedestrian access to the site. Access to the interior of the site requires walking up steep slopes and vehicular access and accessible parking stalls would be needed to meet the requirements of the Americans with Disabilities Act (ADA).

AC Transit's Route 28 serves the project site, with a stop at Stanton Avenue near Jennifer Drive, and provides service to central Castro Valley to the east and Bayfair Center and San Leandro to the northwest. Regional access to the project site is provided by the Miramar Avenue on- and off-ramp of Interstate 580 (I-580), located in San Leandro. Local access to the project site is provided by Stanton Avenue, Lake Chabot Road, and Somerset Avenue.

2.1.4 Regulatory Setting

The project site is subject to the regulatory framework of the Castro Valley Area General Plan adopted in 2012 and is within the Castro Valley Urban Area.¹

¹ Alameda County Community Development Agency, *Castro Valley General Plan*. March 2012.

The project site is designated as Open Space-Park (OS-P) and Hillside Residential (RH) in the Castro Valley Area General Plan and contains three zoning designations according to the Unincorporated Alameda County Zoning Map:² Single-Family Residential (R1) with a Conditional Secondary Unit (CSU) combining district, Recreational Vehicle (RV) combining district, and a Hillside Overlay combining district (R1-CSU-RV-HO); Open Space-Parks with a CSU combining district and RV combining district (OSP-CSU-RV) and Planned Development with a CSU combining district (PD-CSU).

The OS-P land use designation provides for current and expected future locations for public parks of all sizes and types in the community. Parks may include a wide range of uses including active playing fields, recreational facilities including buildings, picnic areas, plazas, bicycle and walking trails, water features, passive green spaces, and landscaped areas. The RH land use designation is used in areas of steep slopes and/or high fire hazard areas to ensure that adequate mitigation are identified for the development of single-family detached dwellings. Lots range from 5,000 to 10,000 square feet resulting in residential densities between 4 and 8 dwelling units per net acre.

The R1 zoning district provides for single-family residential uses. Conditional uses allowed within the R1 zoning district include community facilities, community clubhouses, parking lots, plant nurseries or greenhouses used for the cultivation and wholesale of plant materials, medical or residential care facilities, licensed transitional or supportive housing, mobile home parks, collection boxes, and soil importing. The OSP Zone provides for current and expected future locations for public parks of all sizes and types within the community. These include a wide range of uses including active playing fields recreation facilities including buildings picnic areas plazas, bicycle and walking trails, water features, passive green spaces, and landscaped areas.

The CSU combining district allows for a secondary dwelling unit on a lot zoned for not more than one residence. The RV combining district allows for the parking and storage of personally owned recreational vehicles. The HO combining district is established in areas with steep slopes or near high fire hazards and has a variety of additional development restrictions including design standards, minimum lot size requirement based on average slope of the parcel, and other measures.

2.2 PROJECT BACKGROUND AND OBJECTIVES

The Valley View Park Project is in Castro Valley, an unincorporated community in Alameda County in the San Francisco Bay Area. Castro Valley is a primarily residential community in the East Bay foothills and development occurred rapidly between the 1950s and 1980s, with primarily single-family houses nestled in the hills and commercial development along Castro Valley Boulevard. Lake Chabot Regional Park to the north of the project site provides a recreational resource to Castro Valley, however the community itself has limited park land or recreational amenities. Valley View Park would fulfill an important need for the surrounding neighborhood and for Castro Valley. At the same time, the proposed project would offer a unique open space area in a densifying urban region.

HARD purchased the site in 2014 and initiated a park visioning process with the community the following year. HARD and community priorities from that time were brought together in two

² Alameda County, Community Development Agency, *Zoning Viewer Public Access Map (PAM)*. (Accessed January 6, 2023)

conceptual plan visions that were presented to the HARD Board in September 2015. One concept included a multi-use lawn picnic area, interpretive classroom, playground, dog park, disc golf course and trails through the open space areas. The second replaced the multi-use lawn and playground area with a sports field and a restroom/concession building and added more on-site parking. In 2016, voters passed the Measure F1 Bond, which included \$250,000,000 for repairs, upgrades, and new construction in the District. As a result, the visioning process for Valley View Park was paused so that it could be evaluated comprehensively in the larger context of all parks and facilities.

The HARD Parks Master Plan was completed in 2019 and included data and guidelines for over 100 parks. HARD’s systemwide Parks Master Plan recognizes the importance of the Valley View Park site in addressing a park access gap and indicates a shortfall of certain recreational amenities in Castro Valley, particularly for additional soccer fields. To expand on the findings of the Parks Master Plan, in 2020, HARD conducted focused engagement in Castro Valley to gauge this community’s priorities for recreation. Many residents were aware of the Valley View site and had different perspectives on what improvements should be made. More people felt that park improvements should be low impact, with an emphasis on open space. HARD considered the Valley View site as a possible location for sports fields but determined that other sites in the community were better suited for sports field use due to the topography and access constraints at the Valley View site. Soccer fields at Canyon Middle School are to be updated with synthetic turf and lights, and HARD is finalizing details for new soccer fields at another location.

In February 2022, HARD commenced the planning process for the current Valley View Park Master Plan. The planning process, which lasted to November 2022, included three in-person meetings and one online community workshop. Two online surveys were created and publicized, with over 1,000 responses. Based on the understanding of the site, HARD’s objectives, and community priorities, the planning team was able to define core features of the future Valley View Park including access, recreation features, park elements, and habitat. These features are discussed further in Table 2.A below.

Table 2.A: Proposed Design Features of Valley View Park

Design Feature	Description of Proposed Design Features
Access	<ul style="list-style-type: none"> • Provide access to as many people as possible including younger and older and those with limited mobility options • Integrate park into the fabric of the surrounding neighborhood, with multiple access points • Provide vehicle access and parking at two entrances • Provide access in a way that minimizes impacts to the site’s ecological functions • Provide access for park management and maintenance access through the site
Recreation Features	<ul style="list-style-type: none"> • Paths and trails, enabling use of the site that builds on how people use the site today • Two trail loops: paved loop at the top of the hill, earthen path that loops around the lower portion of the hill • Trails will feature wayfinding markers • Play elements that harness the existing topography and natural character of the site while providing additional recreational value
Park Elements	<ul style="list-style-type: none"> • Single-stall prefab restroom building • Overlook points that include seating and shade connected with an accessible route • Seating throughout the site creating opportunities for rest and views

Table 2.A: Proposed Design Features of Valley View Park

Design Feature	Description of Proposed Design Features
Habitat	<ul style="list-style-type: none"> • Spaces for small groups as well as organized day camp groups to gather • Preserve existing vegetation that provides habitat value • Restore and add plantings, prioritizing species with high ecological value • Design the site so that it can continue to function as part of a larger ecological corridor

The Valley View Park is intended to provide a needed recreational resource and gathering opportunities to the community of Castro Valley and the surrounding residential land uses.

2.3 PROPOSED PROJECT

HARD proposes to implement the Valley View Park Master Plan,³ which would entail development of a new neighborhood park in the unincorporated Alameda County community of Castro Valley (proposed project). The proposed project would include construction of new park facilities and associated improvements (e.g., parking, landscaping, utilities, stormwater), as further detailed below.

2.3.1 Proposed Park Improvements

The proposed project would include the establishment of active and passive open space uses around two concentric walking loops. The walking loops would be connected to the surrounding neighborhoods at two vehicular access points, Sydney Way and Carlton Avenue, and additional access points at all sides of the site for pedestrian access. The upper loop (Hilltop Loop Trail) would be a paved, accessible, multi-use path that follows the contours of the hill in order to provide a continuous view of the surrounding hills, valleys, and distant bay. The lower loop (Native Plant Loop Trail) would be an earthen trail that weaves through trees and areas of native plantings.

Active open space uses including a nature and imaginative play area, multi-purpose grass area, tot play area, dog run, and pump track would be clustered at the northern end of the hilltop and down a fold in the western slope. Passive open space uses would be located on the southern end of the hilltop and distributed along the lower loop. Proposed active and passive open space uses are described further below. The conceptual site plan highlighting these areas is shown in Figure 3.

2.3.1.1 Active Uses

Active open space uses including a nature and imaginative play area, drought tolerant multi-purpose grass area, tot play area, dog run, and pump track would be clustered at the northern end of the hilltop and down a fold in the western slope. These uses are described further below and shown in detail in Figure 4.

³ Hayward Area Recreation and Park District. 2023. *Valley View Park Master Plan*.

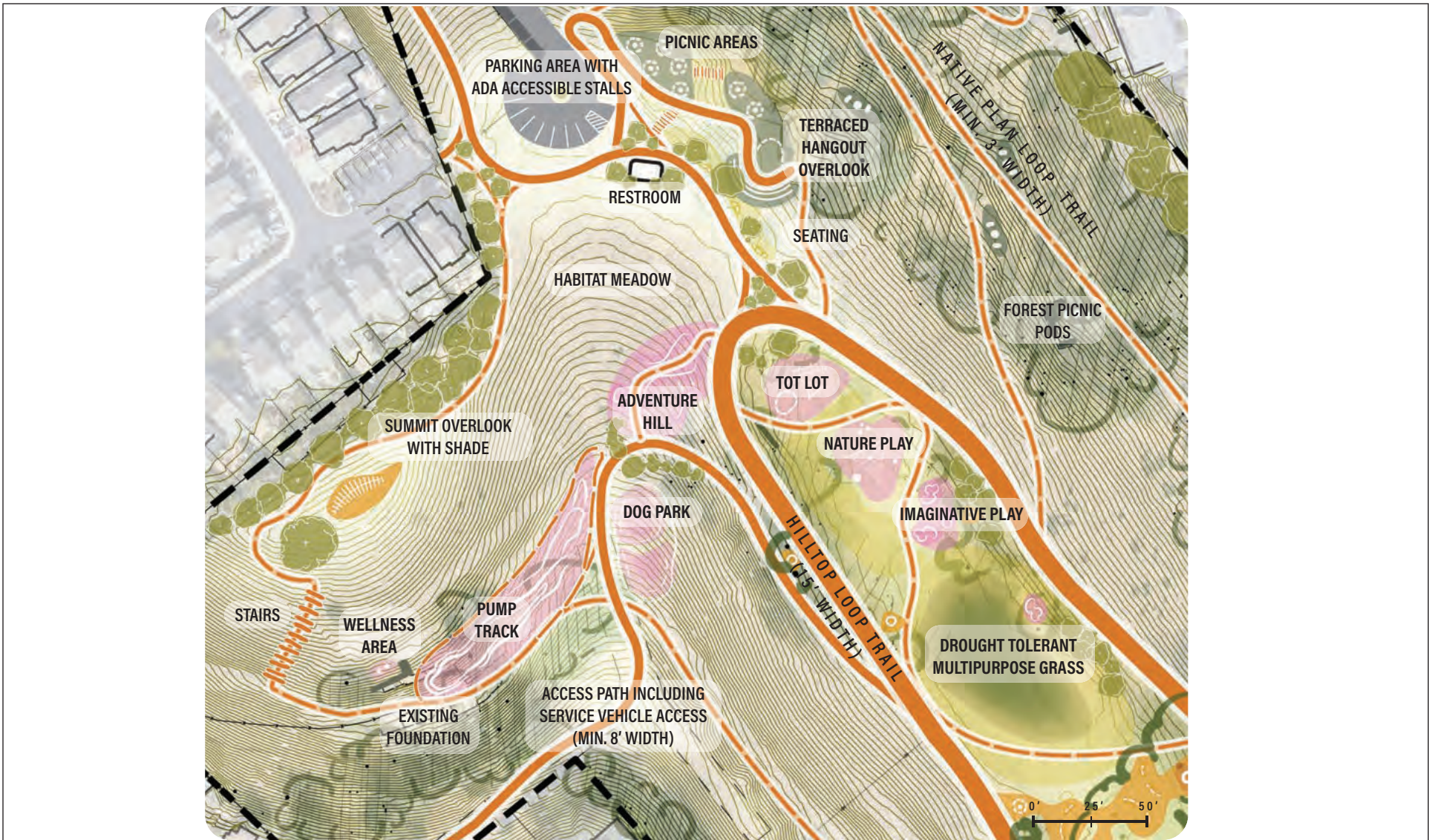
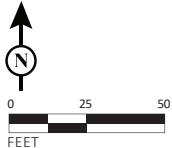

FIGURE 4

LSA



SOURCE: WRT, December 2022

I:\WRT2102\G\Site Detail-Active Uses.ai (1/10/2023)

Valley View Park Master Plan Project
Site Detail - Active Uses

- **Drought Tolerant Multi-purpose Grass.** The center of the park would feature the drought tolerant multi-purpose grass area with the nature and imaginative play area to the north and a reflection grove to the south. The multi-purpose grass area would support activities like pick-up soccer, playing catch and picnicking. This area would be planted with drought-tolerant grass, with a meadowlike perimeter that would blend with the existing annual grasses.
- **Adventure Hill.** The adventure hill consists of play elements that are built into the hillside such as slides, ladders, zip-lines, ropes and stairs appropriate for a variety of ages. Inter-spaced planting will allow these elements to blend with the park aesthetic while providing shade and visual interest.
- **Dog Park.** A fenced zone for dogs to be off-leash would provide space for dogs to exercise, while discouraging unauthorized off-leash dog use elsewhere in the park. Fencing and perimeter landscaping would blend with the natural park setting.
- **Nature and Imaginative Play Area.** Opportunities for play would be distributed in the northern section of the hilltop, including a dedicated zone for tots and nature-based elements that serve all ages. The nature and imaginative play area would utilize natural materials rather than traditional playground structures to help visitors understand the natural place and inspire creativity.
- **Tot Play Area.** A children's play area is proposed along the south boundary of the project site. The proposed playground would be geared toward children aged 3 and under.
- **Pump Track.** An engineered pump track would include paved loops and small jumps to accommodate all ages but targeted for teens. The track would be integrated with the landscape with special attention to the vegetation and materials between the pump track and the rest of the park. The pump track would be designed in a way that minimizes the impact to passive use of the site.
- **Wellness Area.** Two zones with workout equipment would be provided to accommodate a variety of age groups, as well as flexible use platforms that allow for yoga/meditation.
- **Day Camps and Small Group Picnic Areas.** Valley View Park would support various gatherings, including day camps and small group picnics with a picnic area and terraced overlook nestled in the hillside near the north end of the hilltop.
- **Restroom Building.** A prefabricated restroom structure with an integrated shade structure would be provided near the proposed parking area at the north end of the site (off of Sydney Way).

2.3.1.2 Passive Uses

Passive uses would be clustered in the southern portion of the project site and are intended to create spaces for reflection and immersion in nature. These uses are described further below and shown in Figure 5.

This page intentionally left blank

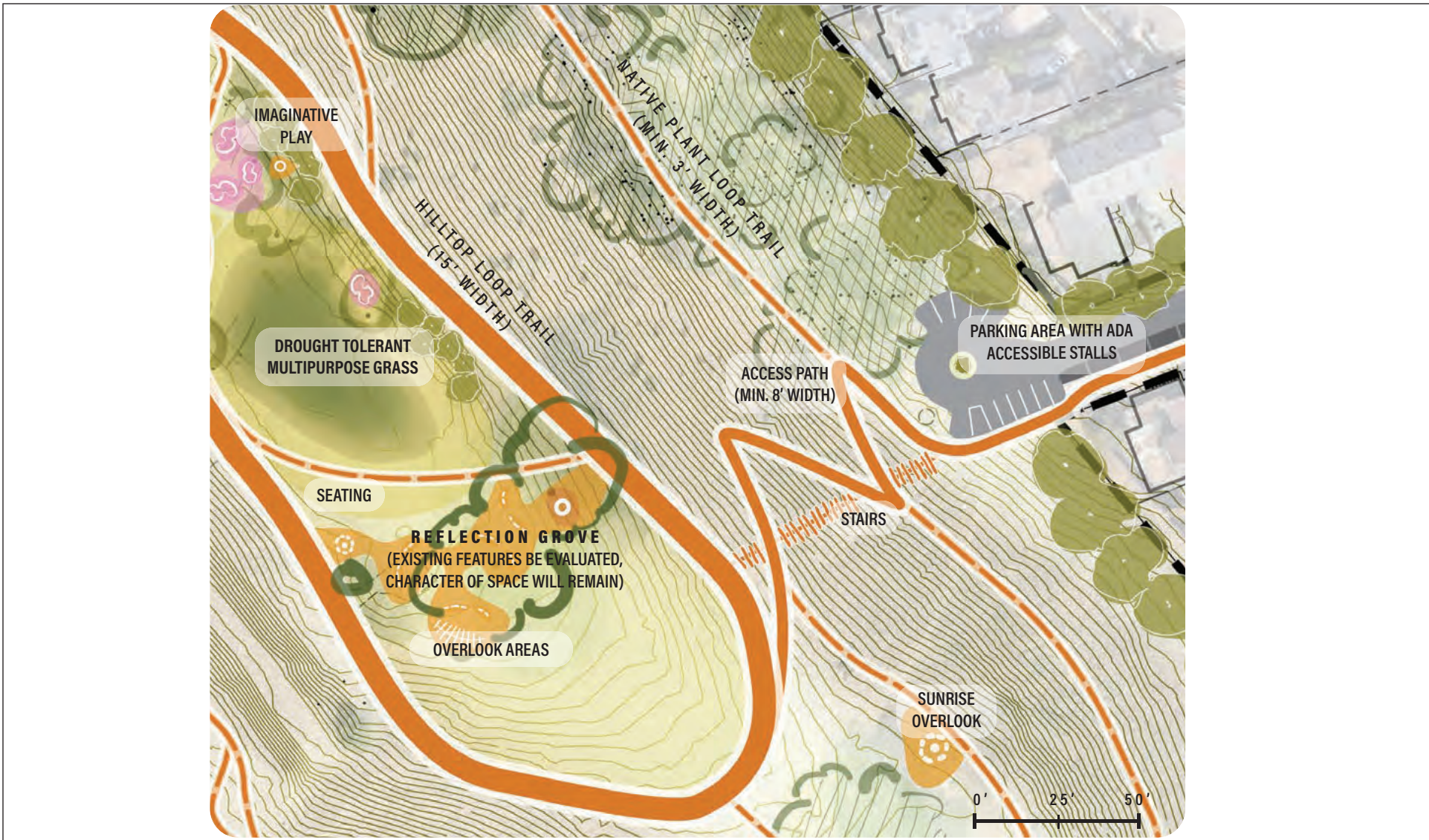
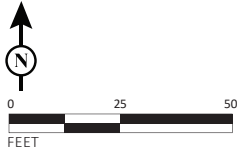

FIGURE 5

LSA



SOURCE: WRT, December 2022

I:\WRT2102\G\Site Detail-Passive Uses.ai (1/10/2023)

Valley View Park Master Plan Project
Site Detail - Passive Uses

This page intentionally left blank

- **Reflection Grove.** A reflection grove is proposed for the southern end of the hilltop. This area has been used, over the years, as a reflective overlook by residents, and includes a tire swing and a memorial. Further investigation is needed to determine if these existing facilities would remain, but HARD intends to preserve the quiet atmosphere of this portion of the project site. Small reflection areas would be established, with associated landscaping.
- **Sunrise Overlook.** A sunrise overlook is identified, providing an intimate place to watch the sunrise. The spot would include a specially-detailed seat, and would be integrated with existing rock outcroppings and surrounding fields where California poppies bloom.
- **Forest Picnic Pods.** The northeastern corner and eastern side of the project site would feature an enhanced, existing forested area. Small gathering areas to have a picnic or read would be provided within the canopy of the enhanced forest.
- **Native Plant Loop.** As described above, an approximately 0.5-mile earthen loop trail would be provided with native/restored plantings and interpretive signage to educate park visitors about the different habitats that exist at the site.

2.3.2 Associated Improvements

In addition to the elements described above, the proposed project would result in the construction of related improvements to complement the new active and passive recreation areas, including parking, landscaping, lighting, slope stabilization, and utilities and stormwater management. These improvements are described below.

2.3.2.1 Parking, Vehicle Access, and Circulation

Existing parking at the project site consists of informal street parking. As part of the proposed project, two new parking areas would be developed to provide vehicle access from Sydney Way and Carlton Avenue. The existing entrances from Sydney Way and Carlton Avenue would be extended into the project site. Each entrance would include approximately 15 to 20 shoulder parking spaces and approximately 8 to 10 parking stalls in the paved parking area, including ADA-accessible parking stalls, for a total of approximately 46 to 60 parking spaces overall. Bicycle parking would also be provided.

The project would also result in the construction of bicycle/pedestrian and service vehicle entrances from Carlton Avenue and Stanton Avenue. Bicycle/pedestrian entrances would also be provided from Jennifer Drive and the existing residential community to the north. As discussed previously, two concentric loop trails would be developed to enhance connectivity and activity within the park and to provide connections to the surrounding neighborhoods.

2.3.2.2 Landscaping

The primary goal of the landscaping plan is to maintain the site's open space character and increase its habitat value. As described above, vegetation at the project site consists primarily of non-native

annual grassland with groves of native and non-native trees. The existing mature tree canopy at the site is a significant contributor to its character and the project would retain the majority of the site's existing trees.

As part of the proposed project, some of the vegetation including diseased, invasive or noxious species of trees and plants may be removed to enhance the landscaping of the site and accommodate planned amenities, road realignments, and parking lots. However, the proposed project would include installation of new landscaping and vegetation to enhance the site's ecological value while also supporting slope stabilization and stormwater management, providing shade, offering visual interest, and screening neighboring homes. New vegetation would include trees, shrubs, grasses, and groundcovers throughout the park. Landscaping would consist of native species or drought tolerant species for water conservation.

Five planting zones were identified for the park (as shown in Figure 6): (1) strategic planting at key nodes with color/seasonal interest to enhance the aesthetic of the site at key locations; (2) native plant zones along paths with a particular emphasis on the native plant loop; (3) screening vegetation along the perimeter of the site; (4) existing vegetation that may serve an important habitat role; and (5) unaltered vegetation throughout the site that would be preserved.

Irrigation would be required for the establishment of species and during extreme drought conditions. Permanent regular irrigation may not be required, but a permanent main line with the ability to attach temporary irrigation at designated stubs may be used. Since much of the native planting would be along the Native Plant Loop Trail, a main line may be embedded in the ground for easy access and maintenance. It is likely pumps would be required for the irrigation system due to the topography.

2.3.2.3 Lighting

Minimal lighting would be provided around entrances and where necessary for safety and wayfinding. Light levels in the park would be kept low after hours to provide for safety/security but are not intended to promote use of the park after the park is closed. Motion sensors may be used to intensify light levels when movement is detected.

2.3.2.4 Security Fencing and Screening

Fencing around the perimeter of the park would be evaluated on a case by case basis, and replaced as needed to provide the desired access, screening, and security. As described in Section 2.3.2.1 above, screening vegetation would be planted along the eastern and southern boundary of the project site to provide privacy for the existing residential uses to the east and south. Screening would be achieved through the planting of trees, and in some cases shrubs.



FIGURE 6

LSA



NOT TO SCALE

SOURCE: WRT, December 2022

I:\WRT2102\G\Planting & Conserved Nat Vegetation.ai (1/10/2023)

Valley View Park Master Plan Project
Planting and Conserved Natural Vegetation

This page intentionally left blank

2.3.2.5 Slope Stabilization

The proposed project has been designed to minimize earthmoving or grading construction activities, with an emphasis on utilizing the site's existing topography. With minimal grading, slopes are not anticipated to become steeper, however existing steep slopes and signs of past slope failure suggest that slope stabilization would be required. The use of fiber roll, jute netting and hydroseeded planting specified for steep, unirrigated slopes would be implemented on the west side of the hill in the center of the site and in the northwest corner of the site. Some earthmoving would occur at the vehicular entry drives and may require small retaining walls or rock walls. Proposed site engineering, including slope stabilization and utility improvements are shown on Figure 7.

2.3.2.6 Utilities and Stormwater Management

Utilities exist under and along all streets adjacent to the project site. The park's needs for irrigation, drinking fountains, restrooms, and fire hydrants would be served by new 6-inch and 2-inch water lines and a 4-inch wastewater line that would connect to existing utilities under Sydney Way.

Under existing conditions, stormwater drainage from the site has been addressed through a variety of techniques implemented by adjacent property owners. Because the proposed site plan would involve minimal changes to existing drainage patterns, only certain areas would require comprehensive stormwater management. Storm drain connections would be developed along both vehicular access points and permeable surfacing and swales would be used to support infiltration and groundwater recharge. In locations where vegetated screens are planted for privacy, an earthen swale could be incorporated to help divert surface water.

Electrical lines would connect to existing lines of Sydney Way and the design of future park elements would consider solar generation to minimize energy use.

2.3.2.7 Fire Management

Coordination with the Alameda County Fire Department would determine the measures that would be implemented to reduce the risk for fire and ensure adequate access for fire equipment and personnel. Fire hydrants would be included in the site development and the upper loop trail may be used as an Emergency Vehicle Access (EVA) lane. Goats are currently utilized for vegetation management on a seasonal basis. Similar strategies would be employed to reduce fuel loads and noxious vegetation when site improvements are implemented. Vegetation would also be maintained to provide defensible space to reduce wildfire risks.

This page intentionally left blank



FIGURE 7

LSA



NOT TO SCALE

SOURCE: WRT, December 2022

I:\WRT2102\G\Site Engineering.ai (1/10/2023)

Valley View Park Master Plan Project
Site Engineering

This page intentionally left blank

2.3.3 Construction

Implementation of the Valley View Park Master Plan would occur in phases depending on HARD/community priorities, permitting requirements, available funds, coordination with neighbors, and site engineering constraints. However, for the purposes of this Initial Study, the environmental analysis assumes that all of these recommended facilities would be constructed in a single phase.

Construction of the proposed project would commence in 2025 and would extend for approximately 12 to 24 months. Construction hours would occur during daylight hours, from approximately 8:00 a.m. to 5:00 p.m. daily. Construction staging would occur on the project site in areas not proposed to support planned improvements. Construction workers, equipment and deliveries would access the site via existing access points from Sydney Way and Carlton Avenue.

Although the proposed project has been designed to minimize earthmoving or grading construction activities, some cut and fill would be required. It is anticipated that a total of 5,340 cubic yards of soils would be moved around the site, and of that 785 cubic yards would need to be amended. To be conservative, this analysis assumes approximately 260 cubic yards of soil may need to be imported for amendments. Consistent with County standards, potable water and fire water lines would be installed approximately 48 inches below ground surface (bgs). Sanitary sewer lines would be installed approximately 60- to 72 inches bgs.

2.3.4 Operation

Valley View Park would be open daily to informal use, including walking, biking, picnicking, pick-up sports and use of general park facilities. The park hours are sunrise to sunset, with no vehicle or pedestrian access at night after dark. Lighting, signage and wayfinding would be used to establish primary and secondary entrances and circulation patterns within the park. Leashed dogs would be allowed in the park. Dogs may be off-leash in the designated dog park.

Maintenance activities would be performed by existing HARD staff and maintenance contractors hired by HARD. Maintenance activities would include mowing, facility cleaning, vegetation management, tree care and maintenance of recreation facilities. The multi-purpose grass area on top of the hill in the center of the site is expected to support active uses, such as sports games, and would require a greater frequency of mowing and weeding compared to the rest of the site. Goats are currently used on the site during the summer months to manage fire risk associated with grassland. Given the variety of trees on the site, an arborist would regularly review trees for liability and disease concerns.

The park is also expected to be used by day camps from the nearby Castro Valley Community Center and may focus their on-site activity at the picnic areas and terraced hangout overlook at the northern end of the hilltop. Day camp use of the park is expected to expand HARD's ability to serve youth and provide new education and recreational opportunities. Elements of the play areas such as sculptures made from natural materials may require special maintenance attention and are expected to be replaced over time. Additionally, the imaginative play area may include loose elements that could be used for the creative assembly of materials into sculptures or small structures and may require signage describing the nature of the zone and additional management and maintenance in order to ensure functionality and safety.

2.4 PROJECT APPROVALS

A number of permits and approvals would be required for the proposed project. While HARD is the Lead Agency for the project, other agencies also have discretionary authority related to the project and approvals. A list of these agencies and potential permits and approvals that may be required is provided in Table 2.B below.

Table 2.B: Potential Permits and Approvals

Lead Agency	Potential Permits/Approvals
HARD	<ul style="list-style-type: none"> ● Project approval ● IS/MND adoption
Other Agencies	
Alameda County	<ul style="list-style-type: none"> ● Provision of grading, demolition, construction, tree removal, parking, traffic, erosion, and Storm Water Pollution Prevention Plan permits and approvals ● Approval of water lines, water hookups, wastewater lines, wastewater hookups
Alameda County Fire Department	<ul style="list-style-type: none"> ● Fire Department review
State Water Resources Control Board	<ul style="list-style-type: none"> ● Coverage under the Construction General Permit
Regional Water Quality Control Board	<ul style="list-style-type: none"> ● Compliance with the Municipal Regional Permit

Source: LSA (2023).

3.0 ENVIRONMENTAL FACTORS POTENTIALLY AFFECTED

The environmental factors checked below would be potentially affected by this project, involving at least one impact that is a “Potentially Significant Impact” as indicated by the checklist in Chapter 3.0.

- | | | |
|--|---|---|
| <input type="checkbox"/> Aesthetics | <input type="checkbox"/> Agriculture and Forestry Resources | <input type="checkbox"/> Air Quality |
| <input type="checkbox"/> Biological Resources | <input type="checkbox"/> Cultural Resources | <input type="checkbox"/> Energy |
| <input type="checkbox"/> Geology/Soils | <input type="checkbox"/> Greenhouse Gas Emissions | <input type="checkbox"/> Hazards & Hazardous Materials |
| <input type="checkbox"/> Hydrology/Water Quality | <input type="checkbox"/> Land Use/Planning | <input type="checkbox"/> Mineral Resources |
| <input type="checkbox"/> Noise | <input type="checkbox"/> Population/Housing | <input type="checkbox"/> Public Services |
| <input type="checkbox"/> Recreation | <input type="checkbox"/> Transportation | <input type="checkbox"/> Tribal Cultural Resources |
| <input type="checkbox"/> Utilities/Service Systems | <input type="checkbox"/> Wildfire | <input type="checkbox"/> Mandatory Findings of Significance |

The Initial Study finds that the proposed project would result in “less than significant with mitigation incorporated” environmental impacts related to the following:

- Air Quality
- Biological Resources
- Cultural Resources
- Geology and Soils
- Hazards and Hazardous Materials
- Noise

3.1 DETERMINATION

On the basis of this initial evaluation:

- I find that the proposed project COULD NOT have a significant effect on the environment, and a NEGATIVE DECLARATION will be prepared.
- I find that although the proposed project could have a significant effect on the environment, there will not be a significant effect in this case because revisions in the project have been made by or agreed to by the project proponent. A MITIGATED NEGATIVE DECLARATION will be prepared.
- I find that the proposed project MAY have a significant effect on the environment, and an ENVIRONMENTAL IMPACT REPORT is required.
- I find that the proposed project MAY have a “Potentially Significant Impact” or “Potentially Significant Unless Mitigated” impact on the environment, but at least one effect (1) has been adequately analyzed in an earlier document pursuant to applicable legal standards, and (2) has been addressed by mitigation measures based on the earlier analysis as described on attached sheets. An ENVIRONMENTAL IMPACT REPORT is required, but it must analyze only the effects that remain to be addressed.

- I find that although the proposed project could have a significant effect on the environment, because all potentially significant effects (a) have been analyzed adequately in an earlier ENVIRONMENTAL IMPACT REPORT or NEGATIVE DECLARATION pursuant to applicable standards, and (b) have been avoided or mitigated pursuant to that earlier ENVIRONMENTAL IMPACT REPORT or NEGATIVE DECLARATION, including revisions or mitigation measures that are imposed upon the proposed project, nothing further is required.

Signature

Date

4.0 CEQA ENVIRONMENTAL CHECKLIST

4.1 AESTHETICS

	Potentially Significant Impact	Less Than Significant with Mitigation Incorporated	Less Than Significant Impact	No Impact
Except as provided in Public Resources Code Section 21099, would the project:				
a. Have a substantial adverse effect on a scenic vista?	<input type="checkbox"/>	<input type="checkbox"/>	<input checked="" type="checkbox"/>	<input type="checkbox"/>
b. Substantially damage scenic resources, including, but not limited to, trees, rock outcroppings, and historic buildings within a state scenic highway	<input type="checkbox"/>	<input type="checkbox"/>	<input checked="" type="checkbox"/>	<input type="checkbox"/>
c. In non-urbanized areas, substantially degrade the existing visual character or quality of public views of the site and its surroundings? (Public views are those that are experienced from a publicly accessible vantage point.) If the project is in an urbanized area, would the project conflict with applicable zoning and other regulations governing scenic quality?	<input type="checkbox"/>	<input type="checkbox"/>	<input checked="" type="checkbox"/>	<input type="checkbox"/>
d. Create a new source of substantial light or glare which would adversely affect day or nighttime views in the area?	<input type="checkbox"/>	<input type="checkbox"/>	<input checked="" type="checkbox"/>	<input type="checkbox"/>

a. Would the project have a substantial effect on a scenic vista? (Less-Than-Significant Impact)

The Castro Valley Area General Plan contains goals and policies to protect the community character and visual quality in the Castro Valley Area, including preserving and enhancing views of natural features, such as the surrounding hillsides, canyons, and creeks, and the small-town character of Castro Valley.⁴ The Castro Valley Area General Plan and the Alameda County Scenic Routes Element identify Crow Canyon Road and Lake Chabot Road as areas of important visual resources.⁵ Crow Canyon Road, approximately 3.2 miles east of the project site, is considered a scenic corridor through Crow Canyon and Lake Chabot Road offers important views of Lake Chabot Regional Park approximately 0.3 miles north of the project site.

The project site is currently an undeveloped hilltop landscape surrounded by residential neighborhoods and features views of Castro Valley including Lake Chabot and regional open spaces, the East Bay Hills including Mount Diablo, the distant San Francisco Bay, and Santa Cruz Mountains. The project site’s topography varies considerably across the site, with a large hill in the center that provides views of the surrounding area from the top and obstructs views of the surrounding area at the base. The proposed project would result in the development of a community park. As part of park design and planning, key viewpoints within the project site have been identified and incorporated into the park’s conceptual design.

⁴ Alameda County Community Development Agency. 2012. *Castro Valley Area General Plan*. March.

⁵ Alameda County. *Scenic Route Element of the Alameda County General Plan*. May 1966 (as amended May 1994).

Visible elements of the proposed project would include the surface parking lots and access roads, nature and imaginative play area, multi-purpose grass area, tot play area, dog run, pump track, retaining walls, walkways, landscaping, and lighting. Proposed improvements would not include any tall structures or landscaping that would reduce, obstruct, or degrade scenic vistas. Additionally, the large hill in the center of the project site would continue to provide views of the surrounding area including Lake Chabot Regional Park and hillsides. The proposed project would also include the installation of new landscaping to complement the existing vegetation on the project site.

Construction activities would be visible from adjacent uses and public roadways. However, the equipment required for construction would only be visible temporarily. As described above, upon completion, project elements would be at grade or low-standing (less than 25 feet tall) and would add to the scenic quality of the area by enhancing natural landscape features and providing public access to key vista points. Therefore, impacts to scenic vistas would be less than significant.

b. Would the project substantially damage scenic resources, including, but not limited to, trees, rock outcroppings, and historic buildings within a state scenic highway? (Less-Than-Significant Impact)

The closest officially designated Scenic Highway to the project site is a segment of Interstate 580 (I-580) approximately 2.6 miles northwest of the project site. A segment of I-580 that passes through Castro Valley approximately 2 miles south of the project site is identified as an eligible California Scenic Highway, although it has not been officially designated. The Scenic Highways Element of the Alameda County General Plan designates Crow Canyon, Cull Canyon, and Lake Chabot roads as scenic routes. Crow Canyon and Cull Canyon roads are over a mile away from the project site. Lake Chabot Road is located approximately 0.5 mile to the north of the project; however, given the distance, intervening development and topography, proposed project improvements would not be visible from any of these County-designated scenic roadways, including Lake Chabot Road.

As described in Section 4.1.a, the proposed project would not impact scenic corridors or other areas considered to be of visual importance. Furthermore, the proposed project would not substantially damage trees, rock outcroppings, or historic buildings as they are not present on the project site. As such, the proposed project would have no impact on scenic resources located within view of a State Scenic Highway.

c. Would the project substantially degrade the existing visual character or quality of the site and its surroundings? (Less-Than-Significant Impact)

Goals and policies in the Castro Valley Area General Plan and the Alameda County General Plan promote the preservation of the County's rural and natural character. The project site is located in an area developed with suburban residential and commercial land uses. Implementation of the proposed project would provide a needed recreational resource and gathering opportunities to serve this residential area, and the greater community of Castro Valley.

While the project site itself is undeveloped, the surrounding area is characterized by urban development, primarily single-family residential development. As noted in Section 2.0, Project Description, the project site is designated as Open Space-Park (OS-P) and Hillside Residential (RH) in

the Castro Valley Area General Plan and is designated as Single-Family Residential with CSU, RV and HO combining districts (R1-CSU-RV-HO), Open Space-Parks with CSU and RV combining districts (OSP-CSU-RV) and Planned Development with CSU combining district (PD-CSU). The CSU combining district allows for a secondary dwelling unit on a lot zoned for not more than one residence. The HO combining district is established in areas with steep slopes or near high fire hazards and has a variety of additional development restrictions including design standards, minimum lot size requirements based on average slope of the parcel, and other measures. Community facilities are a conditionally permitted use within the R-1 district, which has a minimum allowable lot size of 5,000 square feet and a maximum height of 25 feet. As described above, upon completion, project elements would be at grade or low-standing (less than 25 feet tall) and would be consistent with County standards.

Development of the proposed project would enhance the existing visual character of the project area and vicinity by developing the area with a community park. The proposed project would result in the development of public open space areas, including walkways, picnic areas, recreational facilities (e.g. play areas, multi-purpose grass area), and landscaping, preserving and amplifying the existing natural setting of the site.

The proposed project would represent an improvement to the visual quality and character of the project area through development of recreation improvements and open space areas. Therefore, the proposed project would not degrade the existing visual character or quality of the project area and its surroundings. This impact would be less than significant.

d. Would the project create a new source of substantial light or glare which would adversely affect day or nighttime views in the area? (Less-Than-Significant Impact)

The project site is located in a developed area. Streetlights, vehicle head and taillights on nearby roadways, and lighting associated with adjacent development are the existing sources of light and glare in the project area. Similar to other HARD parks, the proposed project would be closed to the public from dusk until dawn. Light levels in the park would be kept low after hours to provide for safety/security but are not intended to promote use of the park after the park is closed.

Consistent with County requirements, all lighting would be cast downward and be at no more than both the minimum height required and the power necessary for the proposed use. Light fixtures would be directed downward and away from adjoining properties and public right of way, so that no on-site light fixture would directly illuminate any off-site areas. With adherence to these requirements, the proposed project would not create a new source of substantial light or glare, such that day or nighttime views in the area would be affected. This impact would be less than significant.

4.2 AGRICULTURE AND FORESTRY RESOURCES

	Potentially Significant Impact	Less Than Significant with Mitigation Incorporated	Less-Than-Significant Impact	No Impact
Would the project:				
a. Convert Prime Farmland, Unique Farmland, or Farmland of Statewide Importance (Farmland), as shown on the maps prepared pursuant to the Farmland Mapping and Monitoring Program of the California Resources Agency, to non-agricultural use?	<input type="checkbox"/>	<input type="checkbox"/>	<input type="checkbox"/>	<input checked="" type="checkbox"/>
b. Conflict with existing zoning for agricultural use, or a Williamson Act contract?	<input type="checkbox"/>	<input type="checkbox"/>	<input type="checkbox"/>	<input checked="" type="checkbox"/>
c. Conflict with existing zoning for, or cause rezoning of, forest land (as defined in Public Resources Code Section 12220(g)), timberland (as defined by Public Resources Code Section 4526), or timberland zoned Timberland Production (as defined by Government Code Section 51104(g))?	<input type="checkbox"/>	<input type="checkbox"/>	<input type="checkbox"/>	<input checked="" type="checkbox"/>
d. Result in the loss of forest land or conversion of forest land to non-forest use?	<input type="checkbox"/>	<input type="checkbox"/>	<input type="checkbox"/>	<input checked="" type="checkbox"/>
e. Involve other changes in the existing environment which, due to their location or nature, could result in conversion of Farmland, to non-agricultural use or conversion of forest land to non-forest use?	<input type="checkbox"/>	<input type="checkbox"/>	<input type="checkbox"/>	<input checked="" type="checkbox"/>

a. *Would the project convert Prime Farmland, Unique Farmland, or Farmland of Statewide Importance (Farmland) as shown on the maps prepared pursuant to the Farmland Mapping and Monitoring Program of the California Resources Agency, to non-agricultural use? (No Impact)*

The project site is currently an undeveloped hilltop landscape in an urbanized area of Alameda County surrounded by residential neighborhoods. Although the project site was developed for agriculture in 1939, all agricultural operations ceased between 1963 and 1968.⁶ Currently, no agricultural uses are located within or adjacent to the project site. Additionally, the project site is classified as “Urban and Built-Up Land” by the State Department of Conservation;⁷ therefore, the proposed project would not involve the conversion of Prime Farmland, Unique Farmland, or Farmland of Statewide Importance to a non-agricultural use and there would be no impact to farmland resources.

b. *Would the project conflict with existing zoning for agricultural use, or a Williamson Act contract? (No Impact)*

The project site is designated as Open Space-Park (OS-P) and Hillside Residential (RH) in the Castro Valley Area General Plan and is designated as Single-Family Residential with CSU, RV and HO

⁶ ACC Environmental Consultants. 2019. *Phase 1 Environmental Site Assessment*. December 18.

⁷ California Department of Conservation. 2016. California Important Farmland Finder. Website: maps.conservation.ca.gov/dlrp/ciff (accessed January 5, 2023).

combining districts (R1-CSU-RV-HO), Open Space-Parks with CSU and RV combining districts (OSP-CSU-RV) and Planned Development with CSU combining district (PD-CSU). None of these zoning designations allow for agricultural use. The project area is not subject to a Williamson Act contract. Therefore, the proposed project would not conflict with existing zoning for agricultural use or a Williamson Act contract, and the proposed project would have no impact.

- c. Would the project conflict with existing zoning for, or cause rezoning of, forest land (as defined in Public Resources Code Section 12220(g)), timberland (as defined by Public Resources Code Section 4526), or timberland zoned Timberland Production (as defined by Government Code Section 51104(g))?* **(No Impact)**

The project site is located within an existing urban area and is zoned R1-CSU-RV-HO, OSP-CSU-RV, and PD-CSU. None of these land use designations allow for timber production. The project site is not considered forest land (as defined in Public Resources Code section 12220[g]), timberland (as defined by Public Resources Code section 4526) and is not zoned Timberland Production (as defined by Government Code section 51104[g]). The proposed project would not conflict with the existing zoning for, or cause rezoning of, forest land or conversion of forest land to non-forest uses. Therefore, the proposed project would have no impact related to forest land, timberland, or timberland zoned Timberland Production.

- d. Would the project result in the loss of forest land or conversion of forestland to non-forest use?* **(No Impact)**

Refer to Section 4.2.1c. The project site is not considered forest land and the proposed project would not result in the loss of forest land or conversion of forestland to non-forest use. No impact would occur.

- e. Would the project involve other changes in the existing environment which, due to their location or nature, could result in conversion of Farmland, to non-agricultural use or conversion of forest land to non-forest use?* **(No Impact)**

Refer to Sections 4.2.1a and 4.2.1c. The project area is located within an existing urban environment. The proposed project would result in the development of a community park on a site that is not utilized for agricultural or forestry operations, therefore the proposed project would not involve other changes which could result in conversion of Farmland or forest land to non-agricultural or non-forest use. No impact would occur.

4.3 AIR QUALITY

Where available, the significance criteria established by the applicable air quality management district or air pollution control district may be relied upon to make the following determinations.

	Potentially Significant Impact	Less Than Significant with Mitigation Incorporated	Less Than Significant Impact	No Impact
Would the project:				
a. Conflict with or obstruct implementation of the applicable air quality plan?	<input type="checkbox"/>	<input type="checkbox"/>	<input checked="" type="checkbox"/>	<input type="checkbox"/>
b. Result in a cumulatively considerable net increase of any criteria pollutant for which the project region is non-attainment under an applicable federal or state ambient air quality standard?	<input type="checkbox"/>	<input checked="" type="checkbox"/>	<input type="checkbox"/>	<input type="checkbox"/>
c. Expose sensitive receptors to substantial pollutant concentrations?	<input type="checkbox"/>	<input type="checkbox"/>	<input checked="" type="checkbox"/>	<input type="checkbox"/>
d. Result in other emissions (such as those leading to odors) adversely affecting a substantial number of people?	<input type="checkbox"/>	<input type="checkbox"/>	<input checked="" type="checkbox"/>	<input type="checkbox"/>

The project site is located in the unincorporated Alameda County community of Castro Valley and is within the jurisdiction of the Bay Area Air Quality Management District (BAAQMD), which regulates air quality in the San Francisco Bay Area and Alameda County. Air quality conditions in the San Francisco Bay Area have improved significantly since the BAAQMD was created in 1955. Ambient concentrations of air pollutants and the number of days during which the region exceeds air quality standards have fallen substantially. In Alameda County, and the rest of the air basin, exceedances of air quality standards occur primarily during meteorological conditions conducive to high pollution levels, such as cold, windless winter nights or hot, sunny summer afternoons.

Within the BAAQMD, ambient air quality standards for ozone, carbon monoxide (CO), nitrogen dioxide (NO₂), sulfur dioxide (SO₂), particulate matter (PM₁₀, PM_{2.5}), and lead (Pb) have been set by both the State of California and the federal government. The State has also set standards for sulfate and visibility. The BAAQMD is under State non-attainment status for ozone and particulate matter standards. The BAAQMD is classified as non-attainment for the federal ozone 8-hour standard and non-attainment for the federal PM_{2.5} 24-hour standard.

a. Would the project conflict with or obstruct implementation of the applicable air quality plan? (Less-Than-Significant Impact)

The applicable air quality plan is the BAAQMD 2017 Clean Air Plan (Clean Air Plan),⁸ which was adopted on April 19, 2017. The Clean Air Plan is a comprehensive plan to improve Bay Area air quality and protect public health. The Clean Air Plan defines control strategies to reduce emissions and ambient concentrations of air pollutants; safeguard public health by reducing exposure to air pollutants that pose the greatest health risk, with an emphasis on protecting the communities most heavily affected by air pollution; and reduce greenhouse gas emissions to protect the climate.

⁸ Bay Area Air Quality Management District (BAAQMD). 2017a. *Clean Air Plan*. April 19.

Consistency with the Clean Air Plan can be determined if the project: (1) supports the goals of the Clean Air Plan; (2) includes applicable control measures from the Clean Air Plan; and (3) would not disrupt or hinder implementation of any control measures from the Clean Air Plan.

Clean Air Plan Goals. The primary goals of the Bay Area Clean Air Plan are to: attain air quality standards; reduce population exposure and protect public health in the Bay Area; and reduce greenhouse gas emissions and protect the climate.

The BAAQMD has established significance thresholds for project construction and operational impacts at a level at which the cumulative impact of exceeding these thresholds would have an adverse impact on the region's attainment of air quality standards. The health and hazards thresholds were established to help protect public health. As discussed below, implementation of the proposed project would result in less than significant operation-period emissions and, with implementation of Mitigation Measure AIR-1, the project would result in less than significant construction-period emissions. Therefore, the project would not conflict with the Clean Air Plan goals.

Clean Air Plan Control Measures. The control strategies of the Clean Air Plan include measures in the following categories: Stationary Source Measures, Transportation Measures, Energy Measures, Building Measures, Agriculture Measures, Natural and Working Lands Measures, Waste Management Measures, Water Measures, and Super-Greenhouse Gas (GHG) Pollutants Measures.

Stationary Source Control Measures. The Stationary Source Measures, which are designed to reduce emissions from stationary sources such as metal melting facilities, cement kilns, refineries, and glass furnaces, are incorporated into rules adopted by the BAAQMD and then enforced by BAAQMD Permit and Inspection programs. Since the project would not include any stationary sources, the Stationary Source Measures of the Clean Air Plan are not applicable to the project.

Transportation Control Measures. The BAAQMD identifies Transportation Control Measures as part of the Clean Air Plan to decrease emissions of criteria pollutants, toxic air contaminants (TACs), and GHGs by reducing demand for motor vehicle travel, promoting efficient vehicles and transit service, decarbonizing transportation fuels, and electrifying motor vehicles and equipment. The proposed project involves the development of a new neighborhood park in Castro Valley, including new park facilities and associated improvements. The proposed project would entail development of a new neighborhood park and would include the establishment of active and passive open space, encouraging walking and bicycling. The walking loops would be connected to the surrounding neighborhoods at two vehicular access points and additional access points at all sides of the site for pedestrian access; therefore, the project would support the ability of visitors to use alternative modes of transportation. In addition, the proposed project is not expected to result in a significant increase in the generation of vehicle trips or vehicle miles traveled (VMT). As such, the project would not conflict with BAAQMD initiatives to reduce vehicle trips and VMT and would provide access to alternate means of transportation.

Energy Control Measures. The Clean Air Plan also includes Energy Control Measures, which are designed to reduce emissions of criteria air pollutants, TACs, and GHGs by decreasing the

amount of electricity consumed in the Bay Area, as well as decreasing the carbon intensity of the electricity used by switching to less GHG-intensive fuel sources for electricity generation. Since these measures apply to electrical utility providers and local government agencies (and not individual projects), the Energy Control Measures of the Clean Air Plan are not applicable to the project.

Building Control Measures. The BAAQMD has authority to regulate emissions from certain sources in buildings such as boilers and water heaters, but has limited authority to regulate buildings themselves. Therefore, the strategies in the control measures for this sector focus on working with local governments that do have authority over local building codes, to facilitate adoption of best GHG control practices and policies. The proposed project would consist of a neighborhood park; therefore, the Building Control Measures of the Clean Air Plan are not applicable to the project.

Agriculture Control Measures. The Agriculture Control Measures are designed to primarily reduce emissions of methane. Since the project does not include any agricultural activities, the Agriculture Control Measures of the Clean Air Plan are not applicable to the project.

Natural and Working Lands Control Measures. The Natural and Working Lands Control Measures focus on increasing carbon sequestration on rangelands and wetlands, as well as encouraging local governments to enact ordinances that promote urban-tree plantings. Since the project does not include the disturbance of any rangelands or wetlands, the Natural and Working Lands Control Measures of the Clean Air Plan are not applicable to the project.

Waste Management Control Measures. The Waste Management Measures focus on reducing or capturing methane emissions from landfills and composting facilities, diverting organic materials away from landfills, and increasing waste diversion rates through efforts to reduce, reuse, and recycle. The project would comply with local requirements for waste management (e.g., recycling and composting services). Therefore, the project would be consistent with the Waste Management Control Measures of the Clean Air Plan.

Water Control Measures. The Water Control Measures focus on reducing emissions of criteria pollutants, TACs, and GHGs by encouraging water conservation, limiting GHG emissions from publicly owned treatment works (POTWs), and promoting the use of biogas recovery systems. Since these measures apply to POTWs and local government agencies (and not individual projects), the Water Control Measures are not applicable to the project.

Super-GHG Control Measures. The Super-GHG Control Measures are designed to facilitate the adoption of best GHG control practices and policies through the BAAQMD and local government agencies. Since these measures do not apply to individual projects, the Super-GHG Control Measures are not applicable to the project.

Clean Air Plan Implementation. As discussed above, the proposed project would generally implement the applicable measures outlined in the Clean Air Plan, including Transportation Control Measures. Therefore, the project would not disrupt or hinder implementation of a control measure from the Clean Air Plan, and this impact would be less than significant.

b. Would the project result in a cumulatively considerable net increase of any criteria pollutant for which the project region is non-attainment under an applicable federal or state ambient air quality standard? (Less-Than-Significant with Mitigation Incorporated)

The BAAQMD is currently designated as a non-attainment area for State and national ozone standards and national particulate matter ambient air quality standards. The BAAQMD non-attainment status is attributed to the region's development history. Past, present, and future development projects contribute to the region's adverse air quality impacts on a cumulative basis. By its very nature, air pollution is largely a cumulative impact. No single project is sufficient in size to, by itself, result in non-attainment of ambient air quality standards. Instead, a project's individual emissions contribute to existing cumulatively significant adverse air quality impacts. If a project's contribution to the cumulative impact is considerable, then the project's impact on air quality would be considered significant.

In developing thresholds of significance for air pollutants, the BAAQMD considered the emission levels for which a project's individual emissions would be cumulatively considerable. If a project exceeds the identified significance thresholds, its emissions would be cumulatively considerable, resulting in significant adverse air quality impacts to the region's existing air quality conditions. The following analysis assesses the potential construction- and operation-related air quality impacts and CO impacts of the proposed project.

Construction Emissions. During construction, short-term degradation of air quality may occur due to the release of particulate matter emissions (i.e., fugitive dust) generated by grading, hauling, and other activities. Emissions from construction equipment are also anticipated and would include CO, nitrogen oxide (NO_x), reactive organic gases (ROG), directly-emitted particulate matter (PM_{2.5} and PM₁₀), and TACs such as diesel exhaust particulate matter.

Site preparation and project construction would involve grading, paving, and other activities. Construction-related effects on air quality from the proposed project would be greatest during the site preparation phase due to the disturbance of soils. If not properly controlled, these activities would temporarily generate particulate emissions. Sources of fugitive dust would include disturbed soils at the construction site. Unless properly controlled, vehicles leaving the site would deposit dirt and mud on local streets, which could be an additional source of airborne dust after it dries. PM₁₀ emissions would vary from day to day, depending on the nature and magnitude of construction activity and local weather conditions. PM₁₀ emissions would depend on soil moisture, silt content of soil, wind speed, and the amount of operating equipment. Larger dust particles would settle near the source, while fine particles would be dispersed over greater distances from the construction site.

Water or other soil stabilizers can be used to control dust, resulting in emission reductions of 50 percent or more. The BAAQMD has established standard measures for reducing fugitive dust emissions (PM₁₀). With the implementation of these Basic Construction Mitigation Measures, fugitive dust emissions from construction activities would not result in adverse air quality impacts.

In addition to dust-related PM₁₀ emissions, heavy trucks and construction equipment powered by gasoline and diesel engines would generate CO, SO₂, NO_x, ROGs and some soot particulate (PM_{2.5}

and PM₁₀) in exhaust emissions. If construction activities were to increase traffic congestion in the area, CO and other emissions from traffic would increase slightly while those vehicles are delayed. These emissions would be temporary and limited to the immediate area surrounding the construction site.

Construction emissions were estimated for the project using the California Emissions Estimator Model (CalEEMod) version 2022.1., consistent with BAAQMD recommendations. Construction activities are expected to begin in 2025 and occur for approximately 12 to 24 months. To be conservative this analysis assumes that construction would occur for 12 months, which was included in CalEEMod. In addition, the proposed project would include the import of 260 cubic yards of soil, which was included in CalEEMod. This analysis also assumes the use of Tier 2 construction equipment. Other construction details are not yet known; therefore, default assumptions (e.g., construction phasing and construction fleet activities) from CalEEMod were used. Construction-related emissions are presented in Table 4.A. CalEEMod output sheets are included in Appendix A.

Table 4.A: Project Construction Emissions (in Pounds Per Day)

Project Construction	ROG	NO _x	Exhaust PM ₁₀	Fugitive Dust PM ₁₀	Exhaust PM _{2.5}	Fugitive Dust PM _{2.5}
Average Daily Emissions	0.5	15.5	0.5	0.5	0.5	0.2
BAAQMD Thresholds	54.0	54.0	54.0	BMP	82.0	BMP
Exceed Threshold?	No	No	No	No	No	No

Source: LSA (February 2023).

BAAQMD = Bay Area Air Quality Management District

BMP = best management practices

NO_x = nitrogen oxides

PM_{2.5} = particulate matter less than 2.5 microns in size

PM₁₀ = particulate matter less than 10 microns in size

ROG = reactive organic gases

As shown in Table 4.A, construction emissions associated with the project would be less than significant for ROG, NO_x, PM_{2.5}, and PM₁₀ exhaust emissions. The BAAQMD requires the implementation of the BAAQMD Basic Construction Mitigation Measures (best management practices) to reduce construction fugitive dust impacts to a less than significant level as follows:

Mitigation Measure AIR-1

In order to meet the Bay Area Air Quality Management District (BAAQMD) fugitive dust threshold, the following BAAQMD Basic Construction Mitigation Measures shall be implemented:

- All exposed surfaces (e.g., parking areas, staging areas, soil piles, graded areas, and unpaved access roads) shall be watered two times per day.
- All haul trucks transporting soil, sand, or other loose material off site shall be covered.
- All visible mud or dirt tracked-out onto adjacent public roads shall be removed using wet power vacuum street sweepers at least once per day. The use of dry power sweeping is prohibited.

- All vehicle speeds on unpaved roads shall be limited to 15 miles per hour.
- All roadways, driveways, and sidewalks to be paved shall be completed as soon as possible.
- Idling times shall be minimized either by shutting equipment off when not in use or reducing the maximum idling time to 5 minutes (as required by the California Airborne Toxic Control Measure Title 13, Section 2485 of the California Code of Regulations [CCR]). Clear signage shall be provided for construction workers at all access points.
- All construction equipment shall be maintained and properly tuned in accordance with manufacturers' specifications. All equipment shall be checked by a certified mechanic and determined to be running in proper condition prior to operation.
- A publicly-visible sign shall be posted with the telephone number and person to contact at Alameda County regarding dust complaints. This person shall respond and take corrective action within 48 hours. The BAAQMD's phone number shall also be visible to ensure compliance with applicable regulations.

As shown in Table 4.A, construction emissions associated with the proposed project would be below established thresholds. In addition, consistent with BAAQMD requirements, Mitigation Measure AIR-1 requires implementation of best management practices (BMPs) during construction to control fugitive dust emissions. Therefore, with implementation of this measure, construction of the proposed project would not result in a cumulatively considerable net increase of any criteria pollutant for which the project region is non-attainment under an applicable federal or State ambient air quality standard, and impacts would be less than significant with mitigation incorporated.

Operational Emissions. Long-term air pollutant emission impacts are those associated with mobile sources (e.g., vehicle trips), energy sources (e.g., electricity and natural gas), and area sources (e.g., architectural coatings and the use of landscape maintenance equipment) related to the proposed project.

PM₁₀ emissions result from running exhaust, tire and brake wear, and the entrainment of dust into the atmosphere from vehicles traveling on paved roadways. Entrainment of PM₁₀ occurs when vehicle tires pulverize small rocks and pavement and the vehicle wakes generate airborne dust. The contribution of tire and brake wear is small compared to the other PM emission processes. Gasoline-powered engines have small rates of particulate matter emissions compared with diesel-powered vehicles.

Energy source emissions result from activities in buildings for which natural gas is used. The quantity of emissions is the product of usage intensity (i.e., the amount of electricity or natural gas) and the emission factor of the fuel source.

Typically, area source emissions consist of direct sources of air emissions located at the project site, including architectural coatings and the use of landscape maintenance equipment. Area source emissions associated with the project would include emissions from the use of landscaping equipment.

Emission estimates for operation of the project were calculated using CalEEMod. Model results are shown in Table 4.B. Trip generation rates for the project were based on the project’s trip generation estimate, as identified in Section 4.17, Transportation. Based on the trip generation estimates, the proposed project would generate approximately 262 new average daily trips.

Table 4.B: Project Operational Emissions

	ROG	NO _x	PM ₁₀	PM _{2.5}
Pounds Per Day				
Mobile Source Emissions	0.9	0.8	0.6	0.1
Area Source Emissions	<0.1	0.0	0.0	0.0
Energy Source Emissions	0.0	0.0	0.0	0.0
Total Emissions	0.9	0.8	0.6	0.1
BAAQMD Thresholds	54.0	54.0	82.0	54.0
Exceed Threshold?	No	No	No	No
Tons Per Year				
Mobile Source Emissions	0.2	0.1	0.1	<0.1
Area Source Emissions	<0.1	0.0	0.0	0.0
Energy Source Emissions	0.0	0.0	0.0	0.0
Total Emissions	0.2	0.1	0.1	<0.1
BAAQMD Thresholds	10.0	10.0	15.0	10.0
Exceed Threshold?	No	No	No	No

Source: LSA (February 2023).

BAAQMD = Bay Area Air Quality Management District

NO_x = nitrogen oxides

PM_{2.5} = particulate matter less than 2.5 microns in size

PM₁₀ = particulate matter less than 10 microns in size

ROG = reactive organic gases

The primary emissions associated with the project are regional in nature, meaning that air pollutants are rapidly dispersed on release or, in the case of vehicle emissions associated with the project, emissions are released in other areas of the San Francisco Bay Area Air Basin. The daily and annual emissions associated with project operational trip generation, energy, and area sources are identified in Table 4.B for ROG, NO_x, PM₁₀, and PM_{2.5}.

The results shown in Table 4.B indicate the project would not exceed the significance criteria for daily or annual ROG, NO_x, PM₁₀ or PM_{2.5} emissions. Therefore, operation of the proposed project would not result in a cumulatively considerable net increase of any criteria pollutant for which the project region is in non-attainment under an applicable federal or State ambient air quality standard. Impacts would be less than significant.

Localized CO Impacts. Emissions and ambient concentrations of CO have decreased dramatically in the Bay Area with the introduction of the catalytic converter in 1975. No exceedances of the State or federal CO standards have been recorded at Bay Area monitoring stations since 1991. The BAAQMD 2017 CEQA Guidelines⁹ include recommended methodologies for quantifying concentrations of localized CO levels for proposed projects. A screening level analysis using guidance from the BAAQMD CEQA Guidelines was performed to determine the impacts of the project. The screening methodology provides a conservative indication of whether the implementation of a proposed project would result in significant CO emissions. According to the BAAQMD CEQA Guidelines, a proposed project would result in a less than significant impact to localized CO concentrations if the following screening criteria are met:

- The project is consistent with an applicable congestion management program established by the county congestion management agency for designated roads or highways, and the regional transportation plan and local congestion management agency plans.
- Project traffic would not increase traffic volumes at affected intersections to more than 44,000 vehicles per hour.
- The project would not increase traffic volumes at affected intersections to more than 24,000 vehicles per hour where vertical and/or horizontal mixing is substantially limited (e.g., tunnel, parking garage, bridge underpass, natural or urban street canyon, or below-grade roadway).

Implementation of the proposed project would not conflict with the policies or programs of the Alameda County Transportation Commission. As identified in Section 4.17, Transportation, the proposed project would generate approximately 15 AM peak hour trips and 24 PM peak hour trips; therefore, the project's contribution to peak hour traffic volumes at intersections in the vicinity of the project site would be well below 44,000 vehicles per hour. Therefore, the proposed project would not result in localized CO concentrations that exceed State or federal standards, and impacts would be less than significant.

c. Would the project expose sensitive receptors to substantial pollutant concentrations? (Less-Than-Significant Impact)

Sensitive receptors are defined as people that have an increased sensitivity to air pollution or environmental contaminants. Sensitive receptor locations include schools, parks and playgrounds, day-care centers, nursing homes, hospitals, and residential dwelling units. The closest sensitive receptors to the project site include residential areas located along the perimeter of the project's boundary line at approximately 10 feet.

Construction activities can expose sensitive receptors to airborne particulates and fugitive dust as well as a small quantity of construction equipment pollutants (i.e., diesel-fueled vehicles and equipment). However, construction contractors would be required to implement Mitigation Measure AIR-1 described above. With implementation of this mitigation measure, project

⁹ Bay Area Air Quality Management District (BAAQMD). 2017b. California Environmental Quality Act Air Quality Guidelines. May.

construction pollutant emissions would be well below the BAAQMD significance thresholds and would not result in substantial pollutant concentrations. Once the project is constructed, the project would not be a source of substantial emissions. Therefore, sensitive receptors would not be exposed to substantial pollutant concentrations during project construction and operation, and impacts would be considered less than significant.

d. Would the project result in other emissions (such as those leading to odors) adversely affecting a substantial number of people? (Less-Than-Significant Impact)

During project construction, some odors may be present due to diesel exhaust. However, these odors would be temporary and limited to the construction period. The proposed project would not include any activities or operations that would generate objectionable odors and once operational, the project would not be a source of odors. Therefore, the proposed project would not result in other emissions (such as those leading to odors) adversely affecting a substantial number of people. This impact would be less than significant.

4.4 BIOLOGICAL RESOURCES

	Potentially Significant Impact	Less Than Significant with Mitigation Incorporated	Less-Than-Significant Impact	No Impact
Would the project:				
a. Have a substantial adverse effect, either directly or through habitat modifications, on any species identified as a candidate, sensitive, or special-status species in local or regional plans, policies, or regulations, or by the California Department of Fish and Game or U.S. Fish and Wildlife Service?	<input type="checkbox"/>	<input checked="" type="checkbox"/>	<input type="checkbox"/>	<input type="checkbox"/>
b. Have a substantial adverse effect on any riparian habitat or other sensitive natural community identified in local or regional plans, policies, regulations or by the California Department of Fish and Game or U.S. Fish and Wildlife Service?	<input type="checkbox"/>	<input type="checkbox"/>	<input type="checkbox"/>	<input checked="" type="checkbox"/>
c. Have a substantial adverse effect on state or federally protected wetlands (including, but not limited to, marsh, vernal pool, coastal, etc.) through direct removal, filling, hydrological interruption, or other means?	<input type="checkbox"/>	<input type="checkbox"/>	<input type="checkbox"/>	<input checked="" type="checkbox"/>
d. Interfere substantially with the movement of any native resident or migratory fish or wildlife species or with established native resident or migratory wildlife corridors, or impede the use of native wildlife nursery sites?	<input type="checkbox"/>	<input type="checkbox"/>	<input checked="" type="checkbox"/>	<input type="checkbox"/>
e. Conflict with any local policies or ordinances protecting biological resources, such as a tree preservation policy or ordinance?	<input type="checkbox"/>	<input type="checkbox"/>	<input checked="" type="checkbox"/>	<input type="checkbox"/>
f. Conflict with the provisions of an adopted Habitat Conservation Plan, Natural Community Conservation Plan, or other approved local, regional, or state habitat conservation plan?	<input type="checkbox"/>	<input type="checkbox"/>	<input type="checkbox"/>	<input checked="" type="checkbox"/>

To identify special-status plant and animal species known to occur or potentially occurring in the project site vicinity, the following resources were queried: 1) California Department of Fish and Wildlife California Natural Diversity Database (CNDDDB¹⁰) for species records within a 5-mile radius of the project site using Geographic Information Systems (GIS) software; 2) California Native Plant Society's (CNPS) Inventory of Rare and Endangered Plants of California¹¹ for records of special-status plant species in the *Hayward, California* 7.5-minute U.S. Geological Survey (USGS) quadrangle; 3) U.S. Fish and Wildlife Service (USFWS) Information for Planning and Consultation on-line system;¹² 4)

¹⁰ California Department of Fish and Wildlife. 2023. California Natural Diversity Database, commercial version dated February 2023. Biogeographic Data Branch, California Department of Fish and Wildlife, Sacramento.

¹¹ California Native Plant Society, Rare Plant Program. 2023. Rare Plant Inventory (online edition, v9.5). Website <https://www.rareplants.cnps.org> [accessed February 21].

¹² United States Fish and Wildlife Service. 2023. Information for Planning and Consultation (IPaC). February 21.

eBird;¹³ and 5) Western Monarch Milkweed Tracker.¹⁴ In addition, a biologist conducted a reconnaissance-level field survey on November 5, 2021. During the survey, preliminary information on vegetation types and wildlife habitat was collected.

The scientific and vernacular nomenclature for the plant and wildlife species used in this analysis are from the following standard sources: plants, Baldwin et al.¹⁵ and updates listed on the Jepson Herbarium website;¹⁶ amphibians and reptiles, Crother¹⁷; birds, American Ornithologists' Union and supplements through 2022¹⁸; and mammals, Bradley et al.¹⁹

Existing Site Conditions

The project site consists of non-native annual grassland vegetation with scattered groves of trees and shrubs. The project site is surrounded by residential and urban development.

Non-native Annual Grasslands

The majority of the project site consists of non-native annual grasslands. During the time of the 2021 survey, grasses were not easily identifiable, but the Biological Resources Constraints Report²⁰ provides a list of several non-native grass species that were observed on the site during a January 13, 2015 reconnaissance-level survey. Non-native plant species observed during the 2021 survey include yellow star thistle (*Centaurea solstitialis*), bristly ox-tongue (*Helminthotheca echioides*), cheeseweed mallow (*Malva parviflora*), clover (*Trifolium* sp.), mustard (*Brassica* sp.), Italian rye grass (*Festuca perennis*), foxtail barley (*Hordeum murinum*), wild oats (*Avena* spp.), sweet fennel (*Foeniculum vulgare*), English plantain (*Plantago lanceolata*), filaree (*Erodium* sp.), sow thistle (*Sonchus arvensis*), common dandelion (*Taraxacum officinale*), smilo grass (*Stipa miliacea*), wild radish (*Raphanus sativus*), and stinkwort (*Diurachia graveolens*). The only native plant observed in the grasslands during the 2021 survey was California poppy (*Eschscholzia californica*).

¹³ eBird. 2023. eBird: An online database of bird distribution and abundance [web application]. Cornell Lab of Ornithology.

¹⁴ Xerces Society for Invertebrate Conservation, Idaho Department of Fish and Game, Washington Department of Fish and Game, National Fish and Wildlife Foundation, and U.S. Fish and Wildlife Service (Xerces et al.). 2023. Western Monarch Milkweed Mapper. Available at: <https://www.monarchmilkweedmapper.org>.

¹⁵ Baldwin, B.G., D.H. Goldman, D.J. Keil, R. Patterson, T.J. Rosatti, and D.H. Wilken, editors. 2012. The Jepson Manual: Vascular Plants of California, Second Edition. University of California Press, Berkeley.

¹⁶ Jepson Flora Project. 2023. Jepson eFlora. Website: ucjeps.berkeley.edu/eflora/

¹⁷ Crother, B.I. (ed.). 2017. Scientific and Standard English Names of Amphibians and Reptiles of North America North of Mexico, with Comments Regarding Confidence in Our Understanding, pp. 1-102. SSAR Herpetological Circular No. 43.

¹⁸ American Ornithologists' Union (AOU). 1998. Check-list of North American Birds. 7th Edition. American Ornithologists' Union, Washington, D.C.

¹⁹ Bradley, R.D., L.K. Ammerman, R.J. Baker, L.C. Bradley, J.A. Cook, R.C. Dowler, D.J. Schmidly, F.B. Stangl, Jr., R.A. Van Den Bussche, and B. Würsig. 2014. Revised Checklist of North American Mammals North of Mexico, 2014. Occasional Papers, Museum of Texas Tech University No. 237.

²⁰ FirstCarbon Solutions. 2015. Biological Resources Constraints Report, EBMUD Parcel/Future Park Site, Castro Valley, Alameda County, California. Prepared for the Hayward Area Recreation and Park District. February 13.

Trees and Shrubs

Groves of trees with shrubs in the understory are growing within portions of the non-native grasslands. Trees observed in the groves include native coast live oak (*Quercus californicus*), Fremont cottonwood (*Populus fremontii*), and black walnut (*Juglans hindsii*) and non-native red ironbark (*Eucalyptus sideroxylon*), Coulter pine (*Pinus coulteri*), Torrey pine (*Pinus torreyana*), acacia (*Acacia* sp.), Italian cypress (*Cupressus sempervirens*), olive (*Olea europaea*), plum (*Prunus* spp.), and Peruvian pepper (*Schinus molle*). Shrubs observed in the understory of the trees include native toyon (*Heteromeles arbutifolia*), coyote brush (*Baccharis pilularis*), and poison oak (*Toxicodendron diversilobum*) and non-native Himalayan blackberry (*Rubus armeniacus*), Victorian box (*Pittosporum undulatum*), Scotch broom (*Cytisus scoparius*), and English ivy (*Hedera helix*).

Developed

Developed portions of the project site include paved asphalt roads and remains of old building foundations.

Soils

Soils on the project site are mapped as Urban land-Tierra complex, 15 to 30 percent slopes, in the central portion of the site and Xerorthents-Altamont complex, 30 to 50 percent slopes in the northern and southern portions of the site²¹. These soils are well drained.

Wildlife

The project site supports suitable habitat for a variety of urban-adapted wildlife species. California ground squirrels (*Otospermophilus beecheyi*) and Botta's pocket gopher (*Thomomys bottae*) burrows were observed in the grasslands and tree squirrel (*Sciurus* sp.) nests were observed in many of the trees. A sharp-tailed snake (*Contia tenuis*) and black-tailed deer (*Odocoileus hemionus*) scat were also observed on the site. Numerous birds were observed foraging on the site during the field survey and additional bird species are likely present during various times of the year. Wildlife species observed during the reconnaissance-level survey are listed in Table 4.3.C. This IS/MND assumes many additional species are likely to occur on the site throughout the year based on the review of other databases.

²¹ United States Department of Agriculture. 2023. Web Soil Survey. Website: <https://websoilsurvey.sc.egov.usda.gov/App/HomePage.htm> (accessed February 21).

Table 4.C: Wildlife Species Observed During the Field Survey

Common Name	Scientific Name	Status
Reptiles		
Sharp-tailed snake	<i>Contia tenuis</i>	R
Birds		
Mourning dove	<i>Zenaida macroura</i>	R
Anna’s hummingbird	<i>Calypte anna</i>	R
Turkey vulture	<i>Cathartes aura</i>	R
Red-breasted sapsucker	<i>Sphyrapicus ruber</i>	W
Nuttall’s woodpecker	<i>Picoides nuttallii</i>	R
Northern flicker	<i>Colaptes auratus</i>	R
Black phoebe	<i>Sayornis nigricans</i>	R
California scrub-jay	<i>Aphelocoma californica</i>	R
American crow	<i>Corvus brachyrhynchos</i>	R
Common raven	<i>Corvus corax</i>	R
Chestnut-backed chickadee	<i>Poecile rufescens</i>	R
Oak titmouse	<i>Baeolophus inornatus</i>	R
Ruby-crowned kinglet	<i>Corthylio calendula</i>	W
Pygmy nuthatch	<i>Sitta pygmaea</i>	R
Northern mockingbird	<i>Mimus polyglottos</i>	R
House finch	<i>Haemorhous mexicanus</i>	R
Lesser goldfinch	<i>Spinus psaltria</i>	R
White-crowned sparrow	<i>Zonotrichia leucophrys</i>	W
Golden-crowned sparrow	<i>Zonotrichia atricapilla</i>	W
California towhee	<i>Melospiza crissalis</i>	R
Yellow-rumped warbler	<i>Setophaga coronata</i>	W
Mammals		
Botta’s pocket gopher	<i>Thomomys bottae</i>	R/burrows
California ground squirrel	<i>Otospermophilus beecheyi</i>	R/tracks
Tree squirrel	<i>Sciurus sp.</i>	R/Nests
Black-tailed deer	<i>Odocoileus hemionus</i>	R

Source: Compiled by LSA (2023).

R = Year-round resident; expected to nest/breed on the Project site or vicinity

W = Winter resident; winters on or near site but migrates out of Bay Area to nest/F

- a. *Would the project have a substantial adverse effect, either directly or through habitat modifications, on any species identified as a candidate, sensitive, or special-status species in local or regional plans, policies, or regulations, or by the California Department of Fish and Game or U.S. Fish and Wildlife Service? (Less-Than-Significant with Mitigation Incorporated)*

Special-status species are defined as follows:

- Species that are listed, formally proposed for listing, or designated as candidates for listing as threatened or endangered under the federal Endangered Species Act (ESA);
- Species that are listed, or designated as candidates for listing, as rare, threatened, or endangered under the California Endangered Species Act (CESA);

- Plant species on California Rare Plant Rank (CRPR) Lists 1A, 1B, and 2 in the CNPS Inventory of Rare and Endangered Plants;
- Animal species designated as Species of Special Concern or Fully Protected by the California Department of Fish and Wildlife (CDFW);
- Species that meet the definition of rare, threatened, or endangered under Section 15380 of the CEQA guidelines; and
- Species considered being a taxon of special concern by the relevant local agencies.

Special-Status Plants

Based on the results of the database search and literature review, 12 special-status plant species were evaluated as potentially occurring in the site vicinity (Table 4.D). The project site has the potential to support nine special-status plant species, based on the presence of grassland habitat (Table 4.B). The grasslands at the site appear to be disturbed with minimal native plant species present and, although unlikely due to prior disturbance at the site, special-status plant species could be present. No special-status plants were observed during the field survey, but the survey was a reconnaissance-level survey that was conducted outside of the blooming period of the plants.

The following nine special-status plant species have a low potential to occur due to the presence of marginal habitat in onsite grasslands, but are nevertheless assumed to be potentially present at the project site:

- Bent-flowered fiddleneck (*Amsinckia lunaris*; CRPR List 1B)
- Big-scale balsamroot (*Balsamorhiza macrolepis*; CRPR List 1B)
- Congdon's tarplant (*Centromadia parryi* ssp. *congdonii*; CRPR List 1B)
- Fragrant fritillary (*Fritillaria liliacea*; CRPR List 1B)
- Diablo helianthella (*Helianthella castanea*; CRPR List 1B)
- Loma Prieta hoita (*Hoita strobilina*; CRPR List 1B)
- Santa Cruz tarplant (*Holocarpha macradenia*; Federally Threatened; State Endangered; CRPR List 1B)
- Woodland woollythreads (*Monolopia gracilens*; CRPR List 1B)
- Most beautiful jewel-flower (*Streptanthus albidus* ssp. *peramoenus*; CRPR List 1B)

Table 4.D: Special-Status Plant Species Evaluated for the Project

Species	Status ¹ (Federal/ State/CRPR)	Habitat/Blooming Period	Potential to Occur
<i>Amsinckia lunaris</i> Bent-flowered fiddleneck	-/-/1B	Occurs on gravelly slopes in valley and foothill grassland, coastal bluff scrub, and openings within cismontane woodland. This species is often found on serpentine Elevation: 5-800 m. Blooms: March-June	Low Potential to Occur. Marginally suitable habitat is present within the project site's grasslands. The closest CNDDB occurrence is approximately 3.3 miles from the site.
<i>Astragalus tener</i> var. <i>tener</i> Alkali milk-vetch	-/-/1B	Annual herb that occurs on playas, vernal pools, and valley and foothill grasslands. Elevation: 1-60 m. Blooms: March-June	No Potential to Occur. No vernal pool habitat occurs within or adjacent to the project site. The closest CNDDB occurrences are an extirpated record from 1888 approximately 2.4 miles from the site, an extirpated record from 1936 approximately 3.7 miles from the site and a possibly extirpated record from 1959 approximately 4.6 miles from the site.
<i>Balsamorhiza macrolepis</i> Big-scale balsamroot	-/-/1B	Open grassy or rocky slopes in valley grassland and foothill woodland. Elevation: 350-1710 m. Blooms: March-June	Low Potential to Occur. Marginally suitable habitat is present within the project site's grasslands. The closest CNDDB occurrence is at Fairmont Ridge, approximately 0.6 mile from the site.
<i>Centromadia parryi</i> ssp. <i>congdonii</i> Congdon's tarplant	-/-/1B	Grazed and un-grazed annual grasslands with alkaline or saline soils and sometimes described as heavy white clay (saline clay soil). Elevation: 1-230 m. Blooms: May-October (November)	Low Potential to Occur. Marginally suitable habitat is present within the project site's grasslands. However, this species is primarily associated with alkaline/saline soil types; these types do not underlie the project site's grasslands. No Congdon's tarplant or other <i>Centromadia</i> tarplant species were observed during the reconnaissance-level survey. The closest CNDDB occurrence is approximately 1 mile from the site.
<i>Eryngium jepsonii</i> Jepson's coyote-thistle	-/-/1B	Vernal pools and valley and foothill grassland with clay soils. Elevation: 3-305 m. Blooms: April-August	No Potential to Occur. No suitable habitat present. The closest CNDDB occurrence is approximately 0.4 mile from the site.

Table 4.D: Special-Status Plant Species Evaluated for the Project

Species	Status ¹ (Federal/ State/CRPR)	Habitat/Blooming Period	Potential to Occur
<i>Fritillaria liliacea</i> Fragrant fritillary	-/-/1B	Coastal scrub, valley and foothill grassland, cismontane woodland, and coastal prairie. Most often on serpentine soils, but not exclusively as other various soils reported, though usually clay. Elevation: 3-410 m. Blooms: February-April.	Low Potential to Occur. Marginally suitable habitat is present within the project site’s grasslands. The closest CNDDB occurrence is approximately 0.3 mile from the site.
<i>Helianthella castanea</i> Diablo helianthella	-/-/1B	Open, grassy sites, usually rocky, axonal soils. Partial shade in broadleafed upland forest, chaparral, cismontane woodland, coastal scrub, riparian woodland, and valley and foothill grassland. Elevation: 200-1300 m. Blooms: March-June	Low Potential to Occur. Marginally suitable habitat is present within the project site’s grasslands. The closest CNDDB occurrence is approximately 1 mile from the site.
<i>Hoita strobilina</i> Loma Prieta hoita	-/-/1B	Chaparral and cismontane woodland, usually on soils that are underlain by ultramafic rock. Elevation: 30-860 m. Blooms: May-July (August-October)	Low Potential to Occur. Marginally suitable habitat is present within the project site’s grasslands. The closest CNDDB occurrence is an 1865 possibly extirpated record from an unknown location in the Oakland Hills, estimated in the CNDDB at approximately 0.1 mile from the site.
<i>Holocarpha macradenia</i> Santa Cruz tarplant	FT/CE/1B	Clay and sandy soils in coastal prairie, coastal scrub, and valley and foothill grassland. Elevation: 10-220 m. Blooms June–October.	Low Potential to Occur. Marginally suitable habitat is present within the project site’s grasslands. This species has largely been extirpated from Contra Costa County, extant populations, none of which occurs within 3 miles of the project site, have been introduced ²² . Due to lack of observations, extirpated status in the County, and on-site disturbance, this plant would not be expected to occur on the site. The closest CNDDB occurrence is a 1915 possibly extirpated record approximately 1.3 miles from the site.

²² California Native Plant Society, Rare Plant Program. 2023. op. cit.

Table 4.D: Special-Status Plant Species Evaluated for the Project

Species	Status ¹ (Federal/ State/CRPR)	Habitat/Blooming Period	Potential to Occur
<i>Monolopia gracilens</i> Woodland wooly threads	-/-/1B	Grassy sites, in openings, sandy to rocky soils in chaparral, serpentine grasslands, cismontane woodland, broadleaved upland forests, and north coast coniferous forests; often seen on serpentine after burns. Elevation: 100-1200 m. Blooms: March-July	Low Potential to Occur. Marginally suitable habitat is present within the project site’s grasslands. However, this species is typically associated with rocky, sandy, and serpentine soils, which are not present on the project site. Therefore, this species is unlikely to occur. The closest CNDDDB occurrence is an 1888 record from an unknown location in the Oakland Hills, estimated in the CNDDDB at approximately 0.1 mile from the site.
<i>Plagiobothrys glaber</i> Hairless popcorn-flower	-/-/1A	Annual herb that occurs often on marshes, swamps, and alkaline meadows and seeps. Elevation: 15-180 m. Blooms: March-May	No Potential to Occur. No suitable habitat present. The closest CNDDDB occurrence is approximately 3.7 miles from the site.
<i>Streptanthus albidus</i> <i>ssp. peramoenus</i> Most beautiful jewel-flower	-/-/1B	Chaparral, cismontane woodland, and valley and foothill grassland in serpentinite soils. Elevation: 94-1,000 m. Blooms: (March) April-September (October)	Low Potential to Occur. Marginally suitable habitat is present within the project site’s grasslands. The closest CNDDDB occurrence is approximately 3.5 miles from the site.

Source: Compiled by LSA (2023).

Source (unless otherwise noted): California Department of Fish and Wildlife (CDFW). 2023. California Natural Diversity Database (CNDDDB), RareFind 5 Commercial Version. California Department of Fish and Wildlife, Biogeographic Data Branch, Sacramento. February.

¹ Status: California Rare Plant Rank (CRPR)

1A = California Rare Plant Rank 1A: Plant species presumed extirpated or extinct because they have not been seen or collected in the wild in California for many years. A plant is extinct if it no longer occurs anywhere.

1B = California Rare Plant Rank 1B: Plant species rare, threatened, or endangered in California and elsewhere.

2B = California Rare Plant Rank 2B: Plant species rare, threatened or endangered in California, but more common elsewhere.

FT = Federally listed as threatened

CE = California State listed as endangered

CNDDDB = California Natural Diversity Database

If present on the project site, implementation of proposed park improvements could adversely affect special-status plant species due to staging and operation of construction vehicles in areas where these species could occur and permanent loss of habitat/species due to development of park facilities. Implementation of the following mitigation measures would reduce potential impacts to a less-than-significant level.

Mitigation Measure BIO-1a

Preconstruction botanical surveys of the project site shall be completed by a qualified botanist according to the CDFW's 2018 *Protocols for Surveying and Evaluating Impacts to Special Status Native Plant Populations and Sensitive Natural Communities*.²³ Surveys shall be floristic in nature, include areas of potential direct impacts and a minimum 50-foot surrounding area, be conducted at the time of year when species are both evident and identifiable, and be replicable. The purpose of these surveys shall be to identify the locations of special-status plants that could be affected during project construction. If special-status plants are not found in the survey area, then no further mitigation is required. If special-status plants are found in the survey area, then Mitigation Measure BIO-1b (below) shall be implemented.

Mitigation Measure BIO-1b

If special-status plant species are identified during the preconstruction botanical surveys, the locations of identified special-status plants shall be recorded by the qualified botanist using a global positioning system (GPS) unit or equivalent and flagged in the field. The GPS data shall be used to create digital and hardcopy maps for distribution to construction inspectors and contractors to inform them of areas where disturbance is prohibited, or where activities are restricted. Special-status plant species identified during surveys shall be submitted to the CNDDDB.

Where possible, identified special-status plants shall be avoided. This avoidance may include making small adjustments to the proposed improvements (within the 50 feet buffer around the development footprint), as well as the following:

- The qualified botanist shall establish an adequate buffer area to exclude activities that could harm an identified special-status plant population that is near the construction area.
- Access during construction may be restricted around special-status plant populations through appropriate field direction by the qualified botanist. This access restriction may include

²³ California Department of Fish and Wildlife (CDFW). 2018. *Protocols for Surveying and Evaluating Impacts to Special Status Native Plant Populations and Sensitive Natural Communities*. State of California, California Natural Resources Agency. March 20.

signage, buffers, seasonal restrictions, and design or no access, depending on the location and special-status species in question.

- HARD and/or its construction contractors shall install a temporary, plastic mesh-type construction fence (Tensor Polygrid or equivalent) at least 4 feet tall around any established buffer areas to prevent encroachment by construction equipment and personnel. The qualified botanist shall determine the exact location of the fencing. The fencing shall be strung tightly on posts set at maximum intervals of 10 feet (3 meters) and shall be checked and maintained weekly until all construction is complete in the area where special-status plant species occur.
- No grading, clearing, storage of equipment or machinery, or other disturbance or construction activity shall occur until all temporary construction fencing has been installed by HARD and its construction contractor, and inspected and approved by the qualified botanist.

If avoidance of special-status populations is not possible, then a Rare Plant Mitigation Plan shall be designed and implemented. CDFW approval of the Rare Plant Mitigation Plan is required before implementation of an activity that could directly or indirectly impact a federally or state listed or CNPS Rare Plant Rank 1A, 1B, 2A, or 2B species, and under no circumstances will state or federally listed plants be impacted without additional consultation with appropriate regulatory agencies. At a minimum, the plan shall include the following elements:

- For annual species, seed shall be collected from plants that will be impacted, seed stored in an appropriate seed banking facility, and a portion of the seeds shall be redistributed in the project vicinity, as directed by the qualified botanist. Individual plants may also be transplanted. For perennial species, seed collection and seed banking may be augmented by transplanting entire plants or cuttings, as directed by the qualified botanist.
- Suitable sites shall be identified on the project site (or other nearby suitable location) and prepared for redistribution of seeds (or transplants) at mitigation ratios that are appropriate for the species lifeform (e.g., annual or perennial) and success based on performance standards calibrated by established

reference populations. The plan shall outline the site preparation activities.

- Monitoring surveys of the seeded or transplanted areas shall be conducted for a minimum of three years. HARD shall prepare monitoring reports that document the monitoring results and the success of the rare plant mitigation program.
- Mitigation will be deemed successful when the mitigation population provides the same ecological functions as the impacted population, after taking into account natural fluctuations in population size, health, etc. This will include each of the relocated species establishes at least one stable population of approximately the same size of the impacted population, defined as species presence and population size over a 3-year period, taking into account fluctuations in local reference populations. If this goal is not achieved in 4 years, then contingency measures shall be implemented. Such measures will include evaluating the environmental or other characteristics affecting plant survival and implementing corrective measures, which may include additional seeding and planting; altering or implementing a weed control regime; or introducing or altering other management activities. Efforts shall continue until the mitigation site meets the success criteria for two consecutive years.

Implementation of Mitigation Measures BIO-1a and BIO-1b would require preconstruction botanical surveys, establishment of buffers (if needed) and implementation of a Rare Plant Mitigation Plan (if needed). These measures would ensure that impacts to special-status plants would be avoided to the extent feasible, and that if impacts cannot be avoided, impacted and surrounding areas would be revegetated to replace the lost plant populations. Therefore, impacts to special-status plant species would be less than significant with mitigation incorporated.

Special-Status Wildlife

Based on the results of the database search, literature review, and the reconnaissance-level field survey, 31 special-status wildlife species were evaluated for the project area (Table 4.E). Of these species, the following were determined to be present or potentially present on the project site due to the presence of suitable habitat or are discussed in detail due to their status and their close proximity of occupied habitat. These species are further discussed below.

- Alameda whipsnake (*Masticophis lateralis euryxanthus*; Federally Threatened, California Threatened)
- Burrowing owl (*Athene cunicularia*; California Species of Special Concern)

- Northern harrier (*Circus hudsonius*; California Species of Special Concern)
- Golden eagle (*Aquila chrysaetos*; California Fully Protected Species)
- White-tailed kite (*Elanus leucurus*; California Fully Protected Species)
- Grasshopper sparrow (*Ammodramus savannarum*; California Species of Special Concern)
- Loggerhead shrike (*Lanius ludovicianus*; California Species of Special Concern)
- San Francisco dusky-footed woodrat (*Neotoma fuscipes annectens*; California Species of Special Concern)
- Pallid bat (*Antrozous pallidus*; California Species of Special Concern)
- Monarch butterfly (*Danaus plexippus*; Candidate Federally Listed)
- Western bumble bee (*Bombus occidentalis*; Candidate State Listed)
- Crotch bumble bee (*Bombus crotchii*; Candidate State Listed)

Alameda Whipsnake. Because of the limited suitable habitat, the project site is not likely to be inhabited by the Alameda whipsnake (*Masticophis lateralis euryxanthus*; Federally and State Threatened). This species may occur at the Lake Chabot Regional Park, but this habitat is separated from the project site by urban development. For an Alameda whipsnake to access the project site from potentially occupied habitat in Lake Chabot Regional Park, it would have to cross Sydney Way and traverse a quarter mile south-southeast to the project site. The lack of high-quality scrub habitat within or immediately adjacent to the project site likely precludes this rare snake species from occurring on the site.

Burrowing Owl. The non-native grasslands provide suitable foraging and burrowing habitat for burrowing owls (*Athene cunicularia*; California Species of Special Concern). This owl could winter and/or nest on-site. California ground squirrel burrows were observed near Sydney Way and behind the residential backyards of the houses southeast of Sydney Circle, but no burrowing owls or burrowing owl sign (i.e., whitewash, owl pellets) were observed at the burrows. The closest CNDDB occurrence is approximately 3.7 miles from the project site. However, the presence of ground squirrel burrows and low grass height in some areas provide suitable habitat conditions for the species and the species could occur in or near construction areas as a wintering or nesting species. Therefore, construction-related activities could result in loss or abandonment of an active burrowing nest nesting through direct disturbance on an occupied burrow or through noise, vibration, or visual disturbance. In addition, construction-related activities could result in harm to winter burrowing owls, should they occur in or near the construction area. Implementation of the following mitigation measure would reduce potential direct impacts to burrowing owl to a less-than-significant level by requiring a preconstruction survey for burrowing owl and establishing buffers around occupied burrows to ensure that no direct or indirect harm to this species would occur.

Table 4.E: Special-Status Wildlife Species Evaluated for the Proposed Project

Species	Status ¹ (Federal/ State)	Habitat Requirements	Potential to Occur
Amphibians			
<i>Ambystoma californiense</i> California tiger salamander	FT/CT	Spends most of its life in underground burrows. Breeds in vernal pools and ponds, including cattle stock ponds. Breeds after the first rains in late fall and early winter, when the wet season allows the salamander to migrate to the nearest pond, a journey that may be over 1 mile and take several days. Lays eggs in small clusters or singly, which hatch after 14 to 21 days. The pools must hold water for a minimum of 12 weeks for the larvae to successfully metamorphose into their terrestrial form.	No Potential to Occur. Although suitable upland habitat is present in the on-site grasslands, no suitable breeding ponds are present on or near the site. Site is surrounded by urban development and isolated from occupied habitat. No CNDDDB occurrences have been recorded within 5 miles of the site.
<i>Rana draytonii</i> California red-legged frog	FT/CSC	Inhabits permanent and temporary pools, streams, freshwater seeps, and marshes in lowlands and foothills. Uses adjacent upland habitat for foraging and refuge. Breeds during the wet season from December through March in slow parts of streams, lakes, reservoirs, ponds, and other waters with emergent vegetation. Lays 300 to 4,000 eggs in a large cluster, which is attached to plants near the water surface. Requires water for 4 to 7 months for tadpoles to complete metamorphosis.	No Potential to Occur. No suitable aquatic habitat present at or near the site. The closest CNDDDB occurrence is approximately 3.7 miles from the site.
<i>Rana boylei</i> Foothill yellow-legged frog (Central Coast Genetic Distinct Population Segment)	Proposed FT/CE	Partly shaded streams with rocky or cobbly substrate that flow at least to May.	No Potential to Occur. No suitable aquatic habitat present at or near the site. The closest CNDDDB occurrence is a possibly extirpated record approximately 1.6 miles from the site.
Reptiles			
<i>Emys marmorata</i> Western pond turtle	-/CSC	Permanent or nearly permanent water (fresh to brackish) in a wide variety of habitat types. Requires basking sites such as steep banks, logs, or rocks. Upland areas with friable soils are required for egg laying.	No Potential to Occur. No suitable aquatic habitat present at or near the site. No CNDDDB occurrences have been recorded within 5 miles of the site.

Table 4.E: Special-Status Wildlife Species Evaluated for the Proposed Project

Species	Status ¹ (Federal/ State)	Habitat Requirements	Potential to Occur
<i>Masticophis lateralis euryxanthus</i> Alameda whipsnake	FT/CT	Lives primarily in scrub and chaparral communities, but has also been observed in nearby grasslands and woodlands. Feeds primarily on lizards. Most active in the spring and fall. Retreats from hot temperatures in the summer and cold temperatures in the winter into burrows or other underground refuges.	Low Potential to Occur. No suitable habitat present at or adjacent to the site. The site is isolated from occupied habitat and surrounded by urban development. The closest CNDDDB occurrence is approximately 1.8 miles from the site.
Birds			
<i>Athene cunicularia</i> Burrowing owl	–/CSC	Nearly or quite level grassland, prairie, and desert floor with short or sparse vegetation. Subterranean nester that generally uses existing mammal burrows (especially of ground squirrels), but will also excavate its own burrows.	Moderate Potential to Occur. Suitable nesting, wintering, and foraging habitat present. On-site California ground squirrel burrows provide suitable burrowing habitat. The closest CNDDDB occurrence is approximately 3.7 miles from the site.
<i>Rallus obsoletus obsoletus</i> California Ridgway's (=clapper) rail	FE/CE, CFP	Tidal salt marshes with sloughs and substantial cordgrass (<i>Spartina</i> sp.) cover.	No Potential to Occur. No suitable habitat present. The closest CNDDDB occurrence is approximately 3.9 miles from the site.
<i>Charadrius nivosus nivosus</i> Western snowy plover	FT/–	Nests in upper areas of sandy beaches (above normal high tide line), barren dikes of salt ponds, and edges of alkali or brackish lakes in inland areas; forages along the water's edge and on exposed mud flats.	No Potential to Occur. No suitable habitat present. Species known to occur in Lake Chabot Regional Park. ² No CNDDDB occurrences have been recorded within 5 miles of the site.
<i>Circus hudsonius</i> Northern harrier	–/CSC	Nests primarily in large expanses of grasslands including fallow agricultural fields, marshes, and meadows.	Low Potential to Occur. The project site provides grasslands suitable for foraging and nesting northern harriers, but lack of cover and limited size of site likely precludes occurrence. Species known to occur in Lake Chabot Regional Park. ² No CNDDDB occurrences have been recorded within 5 miles of the site.
<i>Aquila chrysaetos</i> Golden eagle	–/CFP	Hunts over rolling foothills and mountain areas. Nests in cliff-walled canyons or large trees in open areas.	Low Potential to Occur. Suitable nesting and foraging habitat present, but species not known to nest on the site. Species known to occur in Lake Chabot Regional Park. ² No CNDDDB occurrences have been recorded within 5 miles of the site.

Table 4.E: Special-Status Wildlife Species Evaluated for the Proposed Project

Species	Status ¹ (Federal/ State)	Habitat Requirements	Potential to Occur
<i>Falco peregrinus anatum</i> American peregrine falcon	–/CFP	Typically nests on cliffs. Will also nest on tall office buildings and bridges. Occasionally uses abandoned stick nests built by other raptors or ravens or electrical transmission towers as nest sites.	No Potential to Occur (nesting). The project area does not support suitable nesting habitat, such as tall buildings, cliffs, or bridges. Species could forage over site. Species known to occur in Lake Chabot Regional Park. ² CDFW suppresses this species' occurrences in the CNDDB.
<i>Elanus leucurus</i> White-tailed kite	–/CFP	Nests in shrubs and trees in open areas and forages in adjacent grasslands and agricultural land.	Moderate Potential to Occur. Suitable nesting habitat is present in trees and large shrubs. Suitable foraging habitat present in the grasslands. Species known to occur in Lake Chabot Regional Park. ² No CNDDB occurrences have been recorded within 5 miles of the site.
<i>Sternula antillarum browni</i> California least tern	FE/CE, CFP	Nests on sandy beaches, alkali flats, hard-pan surfaces (salt ponds).	No Potential to Occur. No suitable habitat is present on or near the project site. No CNDDB occurrences have been recorded within 5 miles of the site.
<i>Chaetura vauxi</i> Vaux's swift	–/CSC	Grasslands and agricultural fields; nests in large hollow trees near open water; forages in most habitats but prefers pipes and lakes.	Low Potential to Occur. Suitable foraging habitat present, but no suitable nesting habitat present. Species known to occur in Lake Chabot Regional Park. ² Species not tracked in the CNDDB.
<i>Agelaius tricolor</i> Tricolored blackbird	–/CT, CSC	Breeds in large colonies near freshwater, preferably emergent wetland such as cattails and tules but also in thickets of willow and other shrubs. Requires nearby foraging areas with large numbers of insects.	No Potential to Occur (nesting). Suitable foraging habitat is present in the grasslands. The project site does not support large marshes with emergent vegetation. Based on the lack of current nearby occurrences and suitable breeding habitat, this species is not likely to breed on the site. Species known to occur in Lake Chabot Regional Park. ² No CNDDB occurrences have been recorded within 5 miles of the site.
<i>Ammodramus savannarum</i> Grasshopper sparrow	–/CSC	Occurs in grasslands with coyote brush and other shrubs.	Low Potential to Occur. Marginally suitable breeding and foraging habitat is present, but small size of grassland habitat with limited shrubs likely precludes occurrence. Species known to occur in Lake Chabot Regional Park. ² Species not tracked in the CNDDB.

Table 4.E: Special-Status Wildlife Species Evaluated for the Proposed Project

Species	Status ¹ (Federal/ State)	Habitat Requirements	Potential to Occur
<i>Dendroica petechia brewsteri</i> Yellow warbler	-/CSC	Riparian woodland; nests in dense shrubs or small trees (e.g., willows)	No Potential to Occur (nesting). No suitable nesting habitat present, but could forage on site during migration. Species known to occur in Lake Chabot Regional Park. ² The closest CNDDDB occurrence is approximately 2.1 miles from the site.
<i>Lanius ludovicianus</i> Loggerhead shrike	-/CSC	Open grasslands and woodlands with scattered shrubs, fence posts, utility lines, or other perches. Nests in dense shrubs and lower branches of trees.	Moderate Potential to Occur. This species could nest in the trees and shrubs and forage within grasslands. Species known to occur in Lake Chabot Regional Park. ² No CNDDDB occurrences have been recorded within 5 miles of the site.
Mammals			
<i>Vulpes macrotis mutica</i> San Joaquin kit fox	FE/CT	Found primarily in flat areas with short, sparse vegetation in the southern San Joaquin Valley. Feeds on kangaroo rats and other small rodent species, but will also consume insects, hares, mice, and lizards. Lives in dens that it either excavates itself or moves into atypical dens including manmade structures.	No Potential to Occur. This species is very rare in the region; the project site provides limited foraging and denning habitat and the site's isolation from larger tracts of open space precludes occurrence. No CNDDDB occurrences within 5 miles of the site.
<i>Reithrodontomys raviventris</i> Salt-marsh harvest mouse	FE/CE, CFP	Tidal salt marshes of San Francisco Bay and its tributaries. Requires tall, dense pickleweed (<i>Salicornia</i> sp.) for cover.	No Potential to Occur. No suitable habitat present. The closest CNDDDB occurrence is approximately 3.7 miles from the site.
<i>Neotoma fuscipes annectens</i> San Francisco dusky-footed woodrat	-/CSC	Primarily found along riparian areas within chaparral and woodlands. Feeds mainly on woody plants but also eats acorns, grasses, and fungi. Builds conspicuous stick houses in trees and on the ground.	Low Potential to Occur. Suitable habitat present, but no stick houses observed during field survey. The closest CNDDDB occurrence is approximately 4.5 miles from the site.
<i>Corynorhinus townsendii</i> Townsend's big-eared bat	-/CSC	This species distribution is limited by suitable roosting sites, which include caves, mines, tunnels, buildings, and other manmade structures. Feeds primarily upon moths.	Low Potential to Occur. No suitable roosting habitat present; suitable foraging habitat present. No suitable roosting sites are present near the site. No CNDDDB occurrences within 5 miles of the site.
<i>Antrozous pallidus</i> Pallid bat	-/CSC	Roost in caves, tunnels, and occasionally buildings and hollow trees. Forages over a variety of habitats.	Low Potential to Occur. Suitable habitat in trees may be present at or near the project site. The closest CNDDDB occurrence is approximately 1.6 miles from the site.
<i>Taxidea taxus</i> American badger	-/CSC	Occurs in grassland, scrub, and woodland with loose-textured soils.	No Potential to Occur. Although suitable grasslands and limited prey are present, project site is too small

Table 4.E: Special-Status Wildlife Species Evaluated for the Proposed Project

Species	Status ¹ (Federal/ State)	Habitat Requirements	Potential to Occur
			to provide suitable habitat and is isolated from occupied habitat. No CNDDDB occurrences recorded within 5 miles of the project site.
Insects			
<i>Danaus plexippus</i> Monarch butterfly (California Overwintering Population)	Candidate / Sensitive Winter Roosting Sites	Occurs throughout California wherever milkweed (<i>Asclepias</i> spp.) plants grow. Migration typically occurs September – October. Overwinters along the coast from northern Mendocino to Baja California, Mexico through January – February. Roosts located in wind-protected tree groves (eucalyptus, Monterey pine, cypress) with nectar and water sources nearby. Adults breed from June – September and require milkweeds for laying eggs, larval development, and metamorphosis. Adults utilize other flowering species for nectaring during the breeding season.	Moderate Potential to Occur. Suitable breeding habitat may be present if their host plant, milkweed, is present. Milkweed, monarch butterflies, and monarch butterfly breeding have been recorded in the vicinity. ²⁴ The project area is outside of the known overwintering range of the species. The closest CNDDDB occurrence is approximately 2.9 miles from the site.
<i>Bombus crotchii</i> Crotch bumble bee	–/ Candidate CT	Open grassland and scrub habitats supporting flowering plants, such as <i>Asclepias</i> sp., <i>Chaenactis</i> sp., <i>Lupinus</i> sp., <i>Medicago</i> sp., <i>Phacelia</i> sp., and <i>Salvia</i> sp.	Low Potential to Occur. Marginally suitable habitat is present within the project site’s grasslands, but lack of native flowering plants and prior disturbance at the site likely precludes its occurrence. The closest CNDDDB occurrence is a 1968 record approximately 2.3 miles from the site. Species historically known to occur in the region. ³
<i>Bombus occidentalis</i> Western bumble bee	–/ Candidate CT	Variety of habitat types, supporting native flowering plants. Open grassy areas, urban parks and gardens, chaparral and shrub areas, and mountain meadows. Generalist forager on many plant species. Nests in underground cavities such as old rodent nests and in open west-southwest slopes bordered by trees. Species has declined precipitously perhaps from disease.	Low Potential to Occur. Marginally suitable habitat is present within the project site’s grasslands, but lack of native flowering plants and prior disturbance at the site likely precludes its occurrence. The closest CNDDDB occurrence includes specimens collected in 1954 record approximately 1.5 miles from the site.
<i>Microcina lumi</i> Lum’s micro-blind harvestman	–/–	Xeric habitats in the San Francisco Bay region beneath serpentine rocks in grassland. Known from one location near	No Potential to Occur. No suitable habitat present. The closest CNDDDB occurrence is approximately 0.4

²⁴ Xerces Society for Invertebrate Conservation, Idaho Department of Fish and Game, Washington Department of Fish and Game, National Fish and Wildlife Foundation, and U.S. Fish and Wildlife Service (Xerces et al.). 2023. Western Monarch Milkweed Mapper. Available at: <https://www.monarchmilkweedmapper.org>.

Table 4.E: Special-Status Wildlife Species Evaluated for the Proposed Project

Species	Status ¹ (Federal/ State)	Habitat Requirements	Potential to Occur
		Fairmont Drive in Hayward, Alameda County.	mile from the site.
Crustaceans			
<i>Branchinecta lynchi</i> Vernal pool fairy shrimp	FT/–	Endemic to the grasslands of the Central Valley, and central and south coast mountains in small, clear water sandstone-depression and grassed swale, earth slump, or basalt-flow depression rain-filled pools.	No Potential to Occur. No suitable vernal pools or other seasonal wetlands are present within the project area. Species current range does not include in the project area. No CNDDB records within 5 miles of the site.
Fish			
<i>Hypomesus transpacificus</i> Delta smelt	FT/CE	Only found in estuarine waters from the Sacramento-San Joaquin confluence to San Pablo Bay. Usually found in water with an average salinity concentration of 2 parts per thousand for much of its life cycle, but can tolerate a wide range of salinities and moves into river channels and tidally influenced backwater sloughs.	No Potential to Occur. No suitable habitat is present on or near the site. No CNDDB records within 5 miles of the site.
<i>Oncorhynchus mykiss irideus</i> Steelhead – northern California Distinct Population Segment	FT/–	Requires cool, swift moving perennial streams with clean, unsilted gravel beds for spawning and egg deposition.	No Potential to Occur. No suitable perennial streams are located on the project site. No CNDDB records within 5 miles of the site.

Source: Compiled by LSA (2023).

- ¹ Status: FE = Federally listed as endangered
 FT = Federally listed as threatened
 CE = California State listed as endangered
 CFP = California Fully Protected
 CSC = California species of special concern
 CT = California State listed as threatened

² eBird. 2023. *Species Lists for Lake Chabot Regional Park eBird Hotspots, Alameda County, California.*

³ California Department of Fish and Wildlife (CDFW). 2019. Evaluation of the Petition from the Xerces Society, Defenders of Wildlife, and the Center for Food Safety to List Four Species of Bumble Bees as Endangered Under the California Endangered Species Act. CNDDB = California Natural Diversity Database

Mitigation Measure BIO-2:

Preconstruction activity surveys for burrowing owls shall be performed by a qualified biologist no more than 15 days before initial ground disturbance activities within a construction area. A survey to determine presence or absence may be performed at any time to facilitate passive relocation efforts (which can only occur outside of the nesting season of February 1 to August 31). In addition, a preconstruction activity survey by a qualified biologist must be conducted no more than 15 days prior to the commencement of grading, to confirm the absence of burrowing owls. This survey shall be conducted in all suitable habitat on and within 500 feet of the impact area and shall be conducted in accordance with the CDFW 2012 Staff Report on Burrowing Owl Mitigation (e.g., the surveys shall be conducted during weather conditions suitable for owl detection as recommended in the Staff Report. Surveys shall be conducted within 2 hours of dawn or sunset to maximize the detection of owls).

If burrowing owls are present during the breeding season (generally February 1 to August 31), a 250-foot buffer, within which no new activity will be permissible, shall be maintained between project activities and occupied burrows. Owls present on the site after February 1 shall be assumed to be nesting unless evidence indicates otherwise as confirmed by a qualified biologist. This protected buffer area shall remain in effect until August 31, or based upon monitoring evidence, until the young owls are foraging independently or a qualified biologist has determined that the nest is no longer active. In some cases (e.g., if an activity is not visible from the nest site), it is possible that a breeding-season buffer less than 250 feet would be adequate to avoid disturbance of nesting burrowing owls, but such a variance would be set by a qualified biologist in consultation with the CDFW. In such a case, the biologist shall monitor the behavior of the nesting birds during the first full day of construction activity immediately surrounding the buffer. The biologist shall look for signs of stress such as repeated alarm calls, agitated behavior, or departure of the birds from the nest. If the birds do not show signs of habituation to the new disturbance by resuming their normal nesting activities, work within the vicinity of the nest shall stop and the CDFW shall be consulted to refine the buffer determination. If the birds continue their normal activities, the biologist shall inspect the nest site every 1 to 2 days (the frequency determined in consultation with the CDFW) for as long as the nest is active and work is ongoing within the reduced buffer to confirm that the birds are tolerant of the construction activities.

If burrowing owls are present during the nonbreeding season (generally September 1 to January 31), a 150-foot buffer zone shall be maintained around the occupied burrow(s) if practicable. If such a buffer is not practicable, then a buffer adequate to avoid injury or mortality of owls (based on the determination of a qualified biologist) shall be maintained. If an adequate buffer (as determined by a qualified biologist) cannot be maintained, or if destruction of the burrow is required, the non-nesting birds may be passively relocated subject to CDFW approval of a Burrowing Owl Exclusion Plan.

Implementation of Mitigation Measure BIO-2 requires conducting preconstruction surveys for burrowing owl prior to any work during the breeding season, and establishment of buffers around occupied burrows. Implementation of Mitigation Measure BIO-2 would reduce potential impacts on burrowing owl to a less-than-significant level with mitigation incorporated.

Special-Status Birds and Other Nesting Birds. Suitable habitat for nesting birds is present in the trees, shrubs, grasslands, and structures on and adjacent to the site. As outlined in Table 4.C, several special-status bird species, including northern harrier, golden eagle, white-tailed kite, grasshopper sparrow, and loggerhead shrike could nest in the trees and large shrubs and forage in the non-native grassland habitat within the project site. Other common, non-special-status native bird species whose active nests are protected by the Migratory Bird Treaty Act and/or California Fish and Game Code could also nest in the vegetation on or adjacent to the site. Several bird species were observed foraging during the field survey and some of these and other bird species could nest on or adjacent to the site.

Construction of the proposed project could adversely impact special-status birds or other native migratory bird species. Tree removal, demolition, and construction activities may result in the removal of trees that could be used for nesting. If conducted during the nesting season (February 1 to August 31), such activities could directly impact nesting birds. Construction-related disturbance (e.g., noise, vehicle traffic, personnel working adjacent to nesting habitat) could also indirectly impact nesting birds by causing adults to abandon nearby nests, resulting in nest failure and reduced reproductive potential. Implementation of the following mitigation measure would reduce potential impacts to nesting birds to a less-than-significant level.

Mitigation Measure BIO-3: Prior to construction activities occurring during the nesting bird season (February 1 through August 31), a preconstruction activity surveys for nesting birds shall be conducted by a qualified biologist to ensure that no nests will be disturbed during project implementation. Surveys shall be conducted no more than seven days prior to the initiation of construction activities. During this survey, the biologist shall inspect all trees and other potential nesting habitats (e.g., shrubs, ground and structures) in the impact area plus a surrounding 500-foot buffer (where accessible) for nests. If removal of potential nesting substrate or project grading will occur during more than one nesting season, or in different parts of

the site in phases over the course of a single season, then additional pre-activity surveys must be performed within seven days prior to initiation of work in any particular area. If the preconstruction activity survey does not identify the presence of any active nests on or within 500 feet of the site, construction activities may proceed.

If nests known to have eggs or young, or that cannot be confirmed to be inactive or to lack eggs or young, are found, or adults are demonstrating nesting behavior, a qualified biologist shall establish an appropriate construction-free buffer around each nest. Generally, a buffer of 300 to 500 feet for raptors and 100 feet for songbirds are adequate to avoid causing nest abandonment. The buffer shall remain in place until the qualified biologist has confirmed that the nest is no longer active.

If less than a 100-foot nest buffer is necessary and determined to be appropriate for a particular nest or nests, a qualified biologist shall monitor the nest(s) before construction to document baseline nesting behavior and monitor the nest during construction to ensure nesting birds are not exhibiting signs of stress and territorial behavior. If signs of stress are observed during the monitoring, construction activities shall cease or buffer shall increase, as determined by a qualified biologist, to a sufficient distance where the nesting birds are no longer exhibiting signs of stress.

To prevent encroachment, the buffer shall be clearly marked for avoidance. The established buffer shall remain in effect until the young have fledged or the nest is no longer active as confirmed by the biologist.

Implementation of Mitigation Measure BIO-3 requires a preconstruction survey for nesting birds, establishment of construction-free buffer zones around active nests, and monitoring during construction activities to ensure that no direct or indirect harm to these species would occur. With implementation of Mitigation Measure BIO-3 potential impacts on nesting migratory birds would be reduced to a less-than-significant level with mitigation incorporated.

Roosting Bats. Bats, including special-status bats, such as the pallid bat, could roost in large trees and snags in the project area and forage on the project site. Roosting bats could be disturbed, killed, or injured by tree removal activity, if present in construction areas. Trees may be trimmed or removed as part of the proposed project. Disturbance of roosting special-status bats would be a potentially significant impact. Implementation of the following mitigation measure would reduce potential impacts to roosting bats to a less-than-significant level by requiring a preconstruction habitat assessment and implementation of appropriate methods for tree removal, to ensure that no direct or indirect harm to special-status bat species would occur.

Mitigation Measure BIO-4

Prior to any tree removal during the maternity roosting period (April 15 to August 31) or hibernation period (October 15 to February 28), a focused tree habitat assessment shall be conducted by a qualified biologist of all trees that will be removed or impacted by construction activities. Trees containing suitable potential bat roost habitat features would then be clearly marked. The habitat assessments should be conducted enough in advance to allow preparation of a report with specific recommendations, and to ensure tree removal can be scheduled during seasonal periods of bat activity if required. If it is determined that day roosting bats are unlikely to occur, the tree may be removed as described below. If the absence of roosting bats cannot be confirmed, then the removal of trees providing suitable maternity or hibernation roosting habitat should only be conducted during seasonal periods of bat activity, including:

1. Between March 1 (or after evening temperatures rise above 45F and/or no more than 1/2" of rainfall within 24 hours occurs) and April 15; or
2. Between September 1 and about October 15 (or before evening temperatures fall below 45F and/or more than 1/2" of rainfall within 24 hours occurs).

Appropriate methods shall be used to minimize the potential of harm to bats during tree removal. Such methods may include but are not limited to using a two-step tree removal process. This method is conducted over two consecutive days and works by creating noise and vibration by cutting non-habitat branches and limbs from habitat trees using chainsaws only (no excavators or other heavy machinery) on Day 1. The noise and vibration disturbance, together with the visible alteration of the tree, is very effective in causing bats that emerge nightly to feed, to not return to the roost that night. The remainder of the tree is removed on Day 2. A biologist qualified in two-step tree removal is required on Day 1 to supervise and instruct the tree-cutters who will be on the site conducting the work, but only for a sufficient length of time to train all tree cutters who will conduct two-step removal of habitat trees. The qualified biologist is generally not required on Day 2, unless a very large cavity is present and a large colony is suspected.

Implementation of Mitigation Measure BIO-4 would require a focused habitat assessment, preconstruction survey, tree and structure removal (as needed), and measures for bat exclusion (as needed). Implementation of Mitigation Measure BIO-4 would reduce potential construction-related impacts, both permanent and temporary in nature, on special-status bats to a less-than-significant level with mitigation incorporated.

San Francisco Dusky-Footed Woodrat. The San Francisco dusky-footed woodrat could occur on the project site. Although no woodrat houses/nests were observed during the survey, suitable habitat is present in the trees and understory shrub vegetation (e.g., the Scotch broom) and woodrats could colonize the project site by the time the construction commences. Woodrats could be disturbed, killed, or injured by vegetation removal activity, if present in construction areas. Implementation of the following mitigation measure would reduce potential impacts to San Francisco dusky-footed woodrat to a less-than-significant level by requiring a preconstruction survey, avoiding nests, if possible, and relocating nests, if needed, to ensure that no direct or indirect harm to this species would occur.

Mitigation Measure BIO-5

A qualified biologist shall conduct a preconstruction survey for San Francisco dusky-footed woodrat houses/nests prior to the start of project activities. Surveys shall be conducted in the immediate work area and a 25-foot buffer around those areas. If woodrat nests are present, the nests shall be flagged in the field and delineated on project site maps in order to avoid potential impacts to woodrat nests during construction activities. For any woodrat nests that cannot be avoided, a woodrat nest relocation plan shall be prepared and submitted to CDFW for approval. At a minimum, the plan shall include the phased dismantling and relocation of the nest materials to a suitable location, and the installation of artificial shelters at a ratio of 1:1 per dismantled nest to provide readily accessible refugia for dispersing individuals. If breeding woodrats are present, relocation of houses shall be delayed until the breeding season is over or the qualified biologist otherwise determines that young are no longer present.

Implementation of Mitigation Measure BIO-5 would require a preconstruction survey, establishment of buffers around identified houses/nests, and potential nest relocation, if needed. Implementation of Mitigation Measure BIO-5 would reduce potential impacts to San Francisco dusky-footed woodrat to a less-than-significant level with mitigation incorporated.

Monarch ButterflyThe project site is located outside of the range of wintering monarch butterflies, and therefore, winter roosts (which are considered sensitive by CDFW) would not be impacted by the proposed project. Milkweed (*Asclepias* spp.) plants, if present, could be used by breeding monarch butterflies. Monarch butterfly individuals, milkweed, and breeding monarch butterflies have been recorded in the Castro Valley vicinity.²⁵ The project could impact breeding monarch butterflies if their milkweed host plants are present during project construction activities. Implementation of the following mitigation measure would reduce potential impacts to Monarch

²⁵ Xerces Society for Invertebrate Conservation, Idaho Department of Fish and Game, Washington Department of Fish and Game, National Fish and Wildlife Foundation, and U.S. Fish and Wildlife Service (Xerces et al.). 2023. [op. cit.](#)

butterfly to a less-than-significant level by requiring a preconstruction survey and implementing a salvage and relocation plan for milkweed, if present on the project site.

Mitigation Measure BIO-6

Preconstruction surveys shall be conducted during the monarch breeding season (March 16 through November 30) to determine if milkweed is present in the proposed development footprint and is being used for monarch breeding. Surveys shall be conducted by a qualified biologist no more than 14 days prior to ground or vegetation disturbance activities. The biologist shall search for evidence of monarch eggs, caterpillars, chrysalises, and adults. If active monarch breeding is identified, the milkweed stand shall be avoided until HARD develops and implements a salvage and relocation plan that has been reviewed and approved by the applicable Resource Agencies.

The combined permanent and temporary impacts to milkweed plants shall be mitigated by the application of the milkweed seed to any temporarily disturbed milkweed area in the fall after the completion of grading. Temporary impacts to milkweed habitat would be mitigated by the application of the milkweed seed. Permanent impacts to milkweed plants shall be mitigated at a minimum 1:1 ratio by applying milkweed seed with restored habitat at the project site. The restored habitat shall be protected from future development in perpetuity.

Vegetation removal and ground disturbance shall be limited to the minimum necessary to conduct the project. When work is conducted in the vicinity of the milkweed plants, temporary fencing (orange construction fencing or similar materials) shall be installed around milkweed to ensure no equipment, materials, or construction personnel stray from the work area and impact milkweed beyond impacts already detailed. The fencing shall be removed after project construction is complete.

Crotch Bumble Bee and Western Bumble Bee. The Crotch bumble bee and western bumble bee could occur in grassland and scrub habitat within the project site. Both of these species are rare in the region but could be present at the site. Disturbance related to construction would be a potentially significant impact, if bees are present in the project site during construction. Implementation of the following mitigation measure would reduce potential impacts to Crotch bumble bee and western bumble bee to a less-than-significant level by requiring preconstruction surveys and implementation of a protection plan to ensure that no direct or indirect impacts to this species would occur. **Mitigation Measure BIO-7** To address potential impacts to the Crotch bubble bee and western bubble bee, HARD shall implement the following measures:

- A minimum of two preconstruction surveys conducted within 30 days during appropriate activity periods (i.e., March through September) prior to the start of ground disturbing activities to identify bumble bee activity. The preconstruction surveys shall occur when temperatures are above 60° Fahrenheit (15.5°Celsius) and not during wet conditions (e.g., foggy, raining, or drizzling). The survey shall be conducted at least 2 hours after sunrise and 3 hours before sunset and shall occur at least 1 hour after rain subsides. Preferably, the survey should be conducted during sunny days with low wind speeds (less than 8 miles per hour), but surveying during partially cloudy days or overcast conditions are permissible if the surveyors can still see their own shadow.
- If Crotch or western bumble bees, or potential Crotch or western bumble bees (since bumble bees can be difficult to identify in the field) are observed within the project site, a plan to protect Crotch and/or western bumble bee nests and individuals shall be developed and implemented in consultation with CDFW and USFWS. The plan shall include, but not be limited to, the following measures:
 - Specifications for construction timing and sequencing requirements (e.g., avoidance of raking, mowing, tilling, or other ground disturbance until late March to protect overwintering queen bumble bees);
 - Establishment of appropriate no-disturbance buffers for bumble bee nest sites to avoid impacts to the bees and construction monitoring by a qualified biologist to ensure compliance if bumble bee nests are identified;
 - Restrictions associated with construction practices, equipment, or materials that may harm bumble bees (e.g., avoidance of pesticides/herbicides, BMPs to minimize the spread of invasive plant species);
 - Provisions to avoid Crotch or western bumble bees, or potential Crotch or western bumble bees if observed away from a bumble bee nest during project activity (e.g., ceasing of project activities until the animal has left the active work area on its own volition); and
 - Prescription of an appropriate restoration seed mix targeted for the Crotch and western bumble bee, including native plant species known to be visited by native bumble bee

species and containing a mix of flowering plant species with continual floral availability through the entire active season of the Crotch and western bumble bee (March through September).

With implementation of Mitigation Measures BIO-1 through BIO-7, impacts to special-status plants and wildlife, including burrowing owl, special-status birds and other nesting birds, roosting bats, Monarch butterfly, and Crotch bumble bee and western bumble bee, would be reduced to a less-than-significant level.

b. Would the project have a substantial adverse effect on any riparian habitat or other sensitive natural community identified in local or regional plans, policies, regulations, or by the California Department of Fish and Game or U.S. Fish and Wildlife Service? (No Impact)

The project site contains non-native annual grasslands with scattered native and non-native trees and lacks wetlands or streams. No riparian habitat or other sensitive natural communities are present at the project site. Therefore, the proposed project would not have a substantial adverse effect on any riparian habitat or other sensitive natural community. No impact would occur.

c. Would the project have a substantial adverse effect on federally protected wetlands as defined by Section 404 of the Clean Water Act (including, but not limited to, marsh, vernal pool, coastal, etc.) through direct removal, filling, hydrological interruption, or other means? (No Impact)

No potential Waters of the U.S. or the State were identified within the project site. A patch of tall flatsedge (*Cyperus eragrostis*), a hydrophytic/wetland plant species, was observed growing in the cracks of an existing old asphalt road, but these cracks would not be considered a jurisdictional wetland feature. An old storm drain culvert, which appeared to be collapsed and not functional, is present near an asphalt road, but no wetland vegetation was observed at the bottom of the culvert. This storm drain appears to have connected to a catch basin upslope from the storm drain, which also did not exhibit any wetland characteristics. Therefore, there are no potential jurisdictional waters or wetlands on the project site, and no impact would occur.

d. Would the project interfere substantially with the movement of any native resident or migratory fish or wildlife species or with established native resident or migratory wildlife corridors, or impede the use of native wildlife nursery sites? (Less-Than-Significant Impact)

The proposed project consists of the construction of trails and park improvements within an existing park. The project site is not part of an expected regional wildlife corridor since it does not occur along a major riparian corridor and is surrounded by urban development. The proposed project would not significantly affect the movement of wildlife since wildlife would be able to continue to cross over the trails or move through or around the park improvements. Additionally, the park would be utilized during the daylight hours, when many nocturnal wildlife species are less likely to move through the site.

The project site does not contain native wildlife nursery sites, such as heron rookeries or salmonid spawning areas. Impacts to wildlife that may breed or nest on the site would be mitigated in

accordance with individual Mitigation Measures BIO-2 through BIO-7 for special-status and sensitive wildlife species.

Given that the proposed project would not interfere substantially with the movement of any native resident or migratory fish or wildlife species or with established native resident or migratory wildlife corridors, or impede the use of native wildlife nursery sites, related impacts would be less-than-significant.

e. Would the project conflict with any local policies or ordinances protecting biological resources, such as a tree preservation policy or ordinance? (Less-Than-Significant Impact)

Chapter 7 of the Castro Valley General Plan prioritizes areas for protection by the value of the biological resources. The priority scheme for habitats within Castro Valley is as follows:

- **High Priority** habitats include drainages, oak riparian woodland, General Plan-designated natural open space areas, coastal scrub on both side of the Castro Valley Creek Improved Channel reach, coastal scrub just east of Cull Canyon Drive, and coastal scrub between Jensen Road and Castro Valley Boulevard/Villareal Drive.
- **Moderate Priority** habitats include other coastal scrub areas and grasslands.
- **Low Priority** habitats include non-native dominant habitat.

Figures 7.1 and 7.2 in the *Castro Valley General Plan* show that the project site is located within a non-native dominant habitat zone and is therefore designated as a Low Priority Biological Resources Overlay Zone, as defined above. As outlined in Section 2.0, Project Description, the proposed park is designed to maintain the site's open space character and increase its habitat value through the preservation of existing vegetation and restoration/installation of native landscaping.

In addition, the *Castro Valley General Plan* does state that ornamental landscaping with large trees, shrubs and other vegetation may provide potential nesting habitat for raptors and other special-status bird species known to nest in urbanized areas. As described above, implementation of Mitigation Measure BIO-3 would reduce potential impacts to nesting birds to a less-than-significant level. Therefore, the proposed project would not conflict with the policies or goals of the *Castro Valley General Plan*.

Alameda County has a tree protection ordinance,²⁶ but it only applies to trees in the County right-of-way. The project would not remove any trees from the County right-of-way, the proposed project would not conflict with the County's tree protection policy, and the project would not conflict with any local policies or ordinance protecting biological resources. Therefore, this impact would be less than significant.

²⁶ Alameda County. 2016a. Ordinance No. O-2016-66, amending Chapter 12.11 of Title 12 of the Alameda County General Ordinance Code. December 6.

- f. Would the project conflict with the provisions of an adopted Habitat Conservation Plan, Natural Community Conservation Plan, or other approved local, regional, or state habitat conservation plan? (No Impact)*

The project site is not located within the limits of an adopted Habitat Conservation Plan, Natural Community Conservation Plan, or other approved local, regional, or state habitat conservation plan. Therefore, the proposed project would not conflict with the provisions of any of these plans. No impact would occur.

4.5 CULTURAL RESOURCES

	Potentially Significant Impact	Less Than Significant with Mitigation Incorporated	Less Than Significant Impact	No Impact
Would the project:				
a. Cause a substantial adverse change in the significance of a historical resource pursuant to §15064.5?	<input type="checkbox"/>	<input checked="" type="checkbox"/>	<input type="checkbox"/>	<input type="checkbox"/>
b. Cause a substantial adverse change in the significance of an archaeological resource pursuant to §15064.5?	<input type="checkbox"/>	<input checked="" type="checkbox"/>	<input type="checkbox"/>	<input type="checkbox"/>
c. Disturb any human remains, including those interred outside of formal cemeteries?	<input type="checkbox"/>	<input type="checkbox"/>	<input checked="" type="checkbox"/>	<input type="checkbox"/>

a. Would the project cause a substantial adverse change in the significance of a historical resource pursuant to §15064.5? (Less-Than-Significant with Mitigation Incorporated)

CEQA defines a “historical resource” as a resource which meets one or more of the following criteria:

- Listed in, or eligible for listing in, the California Register of Historical Resources (California Register);
- Listed in a local register of historical resources as defined in Public Resources Code (PRC) Section 5020.1(k);
- Identified as significant in a historical resource survey meeting the requirements of Section 5024.1(g) of the Public Resources Code; or
- Determined to be a historical resource by a project's lead agency (PRC Section 21084.1 and State CEQA Guidelines Section 15064.5[a]).

The California Register defines a “historical resource” as a resource that meets one or more of the following criteria: (1) associated with events that have made a significant contribution to the broad patterns or local or regional history of the cultural heritage of California or the United States; (2) associated with the lives of persons important to local, California, or national history; (3) embodies the distinctive characteristics of a type, period, region, or method of construction or represents the work of a master or possesses high artistic values; or (4) has yielded, or has the potential to yield, information important to the prehistory or history of the local area, California, or the nation. Under CEQA, historical resources can include precontact (i.e., Native American) archaeological deposits, historic-period archaeological deposits, historic buildings, and historic districts.

LSA conducted a cultural resources study for the proposed project consisting of background research and a field survey. The results of the study are summarized below.

Background Research. At LSA's request, the staff of the Northwest Information Center (NWIC) conducted a records search (#21-1263) of the project site and a 0.5-mile radius. The NWIC, an affiliate of the State of California Office of Historic Preservation, is the official State repository of cultural resource records and reports for Alameda County. As part of the background research, LSA also reviewed local and State inventories for cultural resources, contacted the Native American Heritage Commission (NAHC) in Sacramento, and contacted the Hayward Area Historical Society and the San Leandro Historical Society. No recorded cultural resources were identified within the project site or within a 0.5-mile radius.

Sacred Lands File Search. On February 4, 2022, LSA sent an email describing the project with maps depicting the study area to the NAHC requesting a review of the Sacred Lands File to determine the potential presence of Native American cultural resources that might be affected by the proposed project. Cody Campagne, NAHC Cultural Resource Analyst, responded via email on March 24, 2022, stating that a search of the Sacred Lands File for the study area had negative results for Native American cultural resources within the project site.

Field Survey. On April 28th, 2022, a pedestrian field survey was conducted to identify potential archaeological and built environment cultural resources within the project site, as well as to obtain information about the architectural context and land use patterns of the neighborhood. Despite limited surface visibility, an archaeological resource was identified during the field survey consisting of : a segment of Perrich Avenue, two concrete slabs and a cinderblock retaining wall/staircase at 2275 Perrich Avenue, two concrete slabs at 2778 Talbot Avenue, a concrete slab at 2790 Talbot Avenue, and indeterminate foundation(s)/feature(s) at 18791 Carlton Avenue and on APN 84B-425-3 (which no longer has an associated address). It was noted during the survey that all buildings and structures have been removed and the road and foundations/features are deteriorating.

Summary of Results. The NWIC records search identified no cultural resources on the project site. As outlined in Section 2.0, Project Description, the project site is currently an undeveloped hilltop landscape surrounded by residential neighborhoods. The perimeter of the site currently has a variety of fence types and some planting, primarily implemented by adjacent neighborhoods, that provide varying degrees of security and privacy screening.

Various remnant historic-period building elements identified during the survey, including a concrete ring, concrete drain, and three concrete foundations, as well as an asphalt path (previously Perrich Avenue) that connects the project site to Stanton Avenue. Although property-specific research for the project site indicates that these building elements are associated with a historic-period farm, these building remnants were evaluated for significance as a historical resource and were found to be not eligible, either individually or as a group, for inclusion on the California Register of Historical Resources (CRHR) due to a lack of historical significance. Therefore, this resource does not qualify as a historical resource for the purposes of CEQA as defined at PRC Section 21084.1, as defined in Section 5020.1(k), or deemed significant pursuant to criteria set forth in Section 5024.1(g).

As described above, the resource identified on the project site was evaluated as not eligible for listing in the California Register. However, the unnamed creeks would have served as partial food and water sources for Native American populations in the area. Sediment deposits mapped within

the project site (which have potential to contain previously unidentified archaeological deposits) likely extend at least 50 to 65 inches deep throughout the project site.

Given the historic-period development of the buildings within the project site, the proximity of the project site to unnamed creeks, and the types of sediments mapped in the project site, implementation of the project has potential to impact subsurface cultural resources dating to either the historic period or the precontact period. Should archaeological deposits be encountered during project ground disturbance, a substantial adverse change in the significance of a historical resource would occur from its demolition, destruction, relocation, or alteration such that the significance of the resource would be materially impaired (CEQA Guidelines Section 15064.5(b)(1)). To mitigate this potential impact, HARD would be required to implement Mitigation Measure CULT-1. With implementation of Mitigation Measure CULT-1, potential impacts to historical resources would be reduced to less than significant.

Mitigation Measure CULT-1: A qualified professional archaeologist (either an archaeologist who meets the Secretary of the Interior’s Professional Qualifications Standards for Archeology or an archaeologist supervised by such an archaeologist) shall monitor initial ground-disturbing activities associated with project implementation, including clearing and grubbing activities. Archaeological monitoring shall occur during these excavation activities until the Project Archaeologist, based on their observations, is satisfied that there is little likelihood of encountering intact archaeological deposits. The Project Archaeologist may also determine it is appropriate to reduce monitoring to spot-checking on a part-time basis.

Should an archaeological deposit be encountered during project subsurface construction activities, all ground-disturbing activities within 25 feet shall be redirected and a qualified archaeologist meeting the Secretary of the Interior’s Professional Qualifications Standards for Archeology contacted to assess the situation, determine if the deposit qualifies as a historical resource, consult with agencies as appropriate, and make recommendations for the treatment of the discovery. If the deposit is found to be significant (i.e., eligible for listing in the California Register of Historical Resources), HARD shall be responsible for funding and implementing appropriate mitigation measures. Mitigation measures may include recording the archaeological deposit, data recovery and analysis, and public outreach regarding the scientific and cultural importance of the discovery. Upon completion of the selected mitigations, a report documenting methods, findings, and recommendations shall be prepared by the qualified archaeologist and submitted to HARD for review, and the final report shall be submitted to the Northwest Information Center at Sonoma State University. Significant archaeological materials shall be submitted to

an appropriate local curation facility and used for future research and public interpretive displays, as appropriate.

With implementation of Mitigation Measure CULT-1, which requires monitoring, work stoppage in the event of an archaeological discovery, potential impacts to archaeological historical resources would be reduced to a less-than-significant level with mitigation incorporated.

b. Would the project cause a substantial adverse change in the significance of an archaeological resource pursuant to §15064.5? (Less-Than-Significant with Mitigation Incorporated)

According to the CEQA Guidelines, “When a project will impact an archaeological site, a lead agency shall first determine whether the site is an historical resource” (CEQA Guidelines Section 15064.5(c)(1)). Those archaeological sites that do not qualify as historical resources shall be assessed to determine if these qualify as “unique archaeological resources” (California PRC Section 21083.2).

Archaeological deposits identified during project construction (if any) shall be treated by HARD—in consultation with a qualified archaeologist meeting the Secretary of the Interior’s Professional Qualifications Standards for Archeology—in accordance with Mitigation Measure CULT-1. With implementation of Mitigation Measure CULT-1, identified above, impacts to archaeological resources would be less than significant.

c. Would the project disturb any humans remains, including those interred outside of formal cemeteries? (Less-Than-Significant Impact)

Based on previous archaeological investigation and analysis, there is a low potential for the disturbance of archaeological cultural resources or human remains. However, if human remains are encountered at the project site, State Health and Safety Code Section 7050.5 and State CEQA Guidelines Section 15064.5(e)(1) state that no further disturbance shall occur to the area of the find until the County Coroner has made a determination of origin and disposition of the human bone pursuant to PRC Section 5097.98. The County Coroner must be notified of the find immediately and shall make a determination within two working days of being notified. If the remains are determined to be Native American, the County Coroner shall notify the NAHC by phone within 24 hours, and the NAHC shall then immediately determine and notify a Most Likely Descendant (MLD). With the permission of the landowner or his/her authorized representative, the MLD may inspect the site of the discovery. The MLD shall complete the inspection and make recommendations or preferences for treatment of the remains within 48 hours of being granted access to the site. MLD recommendations may include scientific removal and nondestructive analysis of human remains and items associated with Native American burials, preservation of Native American human remains and associated items in place, relinquishment of Native American human remains and associated items to the descendants for treatment, or any other culturally appropriate treatment.

Compliance with Section 7050.5 of the California Health and Safety Code and Public Resources Code Section 5097.98 regarding the treatment of human remains would ensure that potential impacts to human remains would be less than significant.

4.6 ENERGY

	Potentially Significant Impact	Less Than Significant with Mitigation Incorporated	Less Than Significant Impact	No Impact
Would the project:				
a. Result in a potentially significant environmental impact due to wasteful, inefficient, or unnecessary consumption of energy resources during project construction or operation?	<input type="checkbox"/>	<input type="checkbox"/>	<input checked="" type="checkbox"/>	<input type="checkbox"/>
b. Conflict with or obstruct a state or local plan for renewable energy or energy efficiency?	<input type="checkbox"/>	<input type="checkbox"/>	<input checked="" type="checkbox"/>	<input type="checkbox"/>

a. Would the project result in a potentially significant environmental impact due to wasteful, inefficient, or unnecessary consumption of energy resources during project construction or operation? (Less-Than-Significant Impact)

The proposed project would result in a small increase in the demand for electricity and gasoline. The discussion and analysis provided below is based on data included in the California Emissions Estimator Model (CalEEMod) output, which is included in Appendix A.

Construction-Period Energy Use. The proposed project would require grading, site preparation, building, paving, and architectural coating activities during construction. Construction of the proposed project would require energy for the manufacture and transportation of construction materials, preparation of the site for grading activities, and construction of the proposed park improvements. Petroleum fuels (e.g., diesel and gasoline) would be the primary sources of energy for these activities. In order to increase energy efficiency on the site during project construction, the idling times for construction vehicles would be restricted to 5 minutes or less and construction workers would be required to shut off idle equipment, as required by Mitigation Measure AIR-1. In addition, construction activities are not anticipated to result in an inefficient use of energy as gasoline and diesel fuel would be supplied by construction contractors who would conserve the use of their supplies to minimize their costs on the project. Energy usage on the project site during construction would be temporary in nature and would be relatively small in comparison to the State’s available energy sources. Therefore, construction energy impacts would be less than significant.

Operational Energy Use. Operational energy usage is typically associated with natural gas use, electricity consumption, and fuel used for vehicle trips. As described in Chapter 2.0, Project Description, the proposed project would consist of a new neighborhood park and associated improvements, which would not involve the construction of new buildings. As such, the proposed project would not include natural gas consumption. As such, energy use consumed by the proposed project would be associated with electricity consumption associated with minimal lighting provided around entrances and where necessary for safety and wayfinding and fuel used for vehicle trips associated with the project. Energy consumption was estimated for the project using default energy intensities by land use type in CalEEMod. Electricity usage estimates associated with the proposed project are shown in Table 4.F.

In addition, the proposed project would result in energy usage associated with gasoline to fuel project-related trips. Based on the CalEEMod analysis, the proposed project would result in approximately 792,137 vehicle miles traveled (VMT) per year. The average fuel economy for light-duty vehicles (autos, pickups, vans, and SUVs) in the United States has steadily increased from about 14.9 miles per gallon (mpg) in 1980 to 22.9 mpg in 2020.²⁷ The average fuel economy for heavy-duty trucks in the United States has also steadily increased, from 5.7 mpg in 2013 to a projected 8.0 mpg in 2021.²⁸ Therefore, using the United States Environmental Protection Agency’s (USEPA) fuel economy estimates for 2020 and the California diesel fuel economy estimates for 2021, the proposed project would result in the consumption of approximately 28,435 gallons of gasoline per year and approximately 17,557 gallons per year for diesel fuel.

Table 4.F, below, shows the estimated potential increased electricity and fuel demand associated with the proposed project.

Table 4.F: Estimated Annual Energy Use of Proposed Project

Electricity Use (kWh per year)	Natural Gas Use (therms per year)	Gasoline (gallons per year)	Diesel Fuel (gallons per year)
5,151	0.0	28,435	17,557

Source: LSA (February 2023).
kWh = kilowatt hours

As shown in Table 4.F, the estimated potential increased electricity demand associated with the proposed project is 5,151 kilowatt-hours (kWh) per year. In 2021, Alameda County consumed 10,237 GWh or 10,237,401,835 kWh.²⁹ Therefore, electricity demand associated with the proposed project would be less than 0.01 percent of Alameda County’s total electricity demand.

In addition, the proposed project would result in energy usage associated with gasoline and diesel to fuel project-related trips. As shown above in Table 4.F, vehicle trips associated with the proposed project would consume approximately 28,435 gallons of gasoline per year and approximately 17,557 gallons of diesel fuel per year. Based on fuel consumption obtained from CARB’s California Emissions Factor Model, Version 2021 (EMFAC2021), approximately 569.1 million gallons of gasoline and approximately 160.2 million gallons of diesel will be consumed from vehicle trips in Alameda County in 2023. Therefore, gasoline and diesel fuel demand generated by vehicle trips associated with the proposed project would be a minimal fraction of gasoline and diesel fuel consumption in Alameda County.

Therefore, due to the minimal increase in electricity and fuel demand, the proposed project would not result in the wasteful, inefficient, or unnecessary consumption of fuel or energy and would

²⁷ United States Department of Transportation (USDOT). 2017. “Table 4-23: Average Fuel Efficiency of U.S. Light Duty Vehicles.” <https://www.bts.gov/content/average-fuel-efficiency-us-light-duty-vehicles> (accessed August 2022).

²⁸ California Energy Commission (CEC). 2015. Medium and Heavy-Duty Truck Prices and Fuel Economy 2013–2026. Website: efiling.energy.ca.gov/getdocument.aspx?tn=206180 (accessed March 2023).

²⁹ Ibid.

incorporate renewable energy or energy efficiency measures into building design, equipment uses, and transportation. Construction and operation period impacts related to consumption of energy resources would be less than significant.

b. Conflict with or obstruct a state or local plan for renewable energy or energy efficiency? (Less-Than-Significant Impact)

In 2002, the State Legislature passed Senate Bill (SB) 1389, which required the California Energy Commission (CEC) to develop an integrated energy plan every 2 years for electricity, natural gas, and transportation fuels for the California Energy Policy Report. The plan calls for the State to assist in the transformation of the transportation system to improve air quality, reduce congestion, and increase the efficient use of fuel supplies with the least environmental and energy costs. To further this policy, the plan identifies a number of strategies, including assistance to public agencies and fleet operators in implementing incentive programs for zero emission vehicles and their infrastructure needs, and encouragement of urban designs that reduce VMT and accommodate pedestrian and bicycle access.

The most recently adopted CEC energy report is the 2022 Integrated Energy Policy Report Update.³⁰ The 2022 Integrated Energy Policy Report Update provides the results of the CEC's assessments of a variety of energy issues facing California. Many of these issues will require action if the State is to meet its climate, energy, air quality, and other environmental goals while maintaining energy reliability and controlling costs. The Integrated Energy Policy Report covers a broad range of topics, including implementation of SB 350, integrated resource planning, distributed energy resources, transportation electrification, solutions to increase resiliency in the electricity sector, energy efficiency barriers faced by disadvantaged communities, demand response, transmission and landscape-scale planning, the California Energy Demand Preliminary Forecast, the preliminary transportation energy demand forecast, renewable gas (in response to SB 1383), updates on Southern California electricity reliability, natural gas outlook, and climate adaptation and resiliency.

As indicated above, energy usage on the project site during construction would be temporary in nature. In addition, energy usage associated with operation of the proposed project would be relatively small in comparison to the State's available energy sources, and energy impacts would be negligible at the regional level. Because California's energy conservation planning actions are conducted at a regional level, and because the project's total impact to regional energy supplies would be minor, the proposed project would not conflict with California's energy conservation plans as described in the CEC 2022 Integrated Energy Policy Report. Therefore, the proposed project would not conflict with or obstruct a State or local plan for renewable energy or energy efficiency, and this impact would be less than significant.

³⁰ California Energy Commission (CEC). 2022. *2022 Integrated Energy Policy Report Update*. Website: <https://www.energy.ca.gov/data-reports/reports/integrated-energy-policy-report/2022-integrated-energy-policy-report-update> (accessed March 2023).

4.7 GEOLOGY AND SOILS

	Potentially Significant Impact	Less Than Significant with Mitigation Incorporated	Less Than Significant Impact	No Impact
Would the project:				
a. Directly or indirectly cause potential substantial adverse effects, including the risk of loss, injury, or death involving:				
i. Rupture of a known earthquake fault, as delineated on the most recent Alquist-Priolo Earthquake Fault Zoning Map issued by the State Geologist for the area or based on other substantial evidence of a known fault? Refer to Division of Mines and Geology Special Publication 42.	<input type="checkbox"/>	<input type="checkbox"/>	<input type="checkbox"/>	<input checked="" type="checkbox"/>
ii. Strong seismic ground shaking?	<input type="checkbox"/>	<input type="checkbox"/>	<input checked="" type="checkbox"/>	<input type="checkbox"/>
iii. Seismic-related ground failure, including liquefaction?	<input type="checkbox"/>	<input type="checkbox"/>	<input checked="" type="checkbox"/>	<input type="checkbox"/>
iv. Landslides?	<input type="checkbox"/>	<input type="checkbox"/>	<input checked="" type="checkbox"/>	<input type="checkbox"/>
b. Result in substantial soil erosion or the loss of topsoil?	<input type="checkbox"/>	<input type="checkbox"/>	<input checked="" type="checkbox"/>	<input type="checkbox"/>
c. Be located on a geologic unit or soil that is unstable, or that would become unstable as a result of the project, and potentially result in on- or off-site landslide, lateral spreading, subsidence, liquefaction or collapse?	<input type="checkbox"/>	<input type="checkbox"/>	<input checked="" type="checkbox"/>	<input type="checkbox"/>
d. Be located on expansive soil, as defined in Table 18-1-B of the Uniform Building Code (1994), creating substantial direct or indirect risks to life or property?	<input type="checkbox"/>	<input type="checkbox"/>	<input checked="" type="checkbox"/>	<input type="checkbox"/>
e. Have soils incapable of adequately supporting the use of septic tanks or alternative waste water disposal systems where sewers are not available for the disposal of waste water?	<input type="checkbox"/>	<input type="checkbox"/>	<input type="checkbox"/>	<input checked="" type="checkbox"/>
f. Directly or indirectly destroy a unique paleontological resource or site or unique geologic feature?	<input type="checkbox"/>	<input checked="" type="checkbox"/>	<input type="checkbox"/>	<input type="checkbox"/>

Information presented in this analysis is based on the site-specific Geotechnical Investigation Report prepared for the proposed project.^{31 32}

- a. *Would the project directly or indirectly cause potential substantial adverse effects, including the risk of loss, injury, or death involving:*
 - i. *Rupture of a known earthquake fault, as delineated on the most recent Alquist-Priolo Earthquake Fault Zoning Map issued by the State Geologist for the area or based on other substantial evidence of a known fault? Refer to Division of Mines and Geology Special Publication 42. (No Impact)*

The San Francisco Bay Area is one of the most seismically active regions in the United States. The significant earthquakes that occur in the Bay Area are generally associated with crustal movement along well-defined active fault zones of the San Andreas Fault system, which regionally trend in a

³¹ BSK Associates. *Preliminary Geotechnical Investigation Report Valley View Park Project Castro Valley, California*. March 24, 2020.

³² The Preliminary Geotechnical Investigation Report can be made available for review upon request to HARD.

northwesterly direction. Fault rupture is generally expected to occur along active fault traces that have exhibited signs of recent geological movement (i.e., within the last 11,000 years).

The State of California enacted the Alquist-Priolo Earthquake Fault Zoning Act in 1972, requiring the State Geologist to delineate Earthquake Fault Zones (EFZs) along known active faults that have high potential for fault rupture. Active faults are defined as a fault that has surface displacement within the last 11,000 years.³³ Alquist-Priolo Earthquake Fault Zones delineate areas around active faults with potential surface fault rupture hazards that would require specific geological investigations prior to approval of certain kinds of development within the delineated area. State regulations prohibit habitable structures from being sited within 50 feet of an active fault.

Although the project site is located in a highly active seismic area of California, it is not located within an Alquist-Priolo Earthquake Fault Zone and no mapped active fault traces are known to traverse the site. The closest active fault to the project site is the Hayward Fault located approximately 0.7 miles southwest of the project site. Based on the distance of the nearest mapped fault from the project site, rupture of the Hayward Fault through the project site is not anticipated, and the proposed project would not directly or indirectly cause substantial adverse effects related to fault rupture.

ii. Strong seismic ground shaking? (Less-Than-Significant Impact)

Due to the location of the project site in a seismically active area, strong seismic ground shaking at the site is highly probable during the life of the project. The intensity of ground shaking would depend on the characteristics of the fault, distance from the fault, the earthquake magnitude and duration, and site-specific geologic conditions. An earthquake of moderate to high magnitude generated within the San Francisco Bay Region could cause considerable ground shaking at the site, similar to that which has occurred in the past in the area.

The most significant adverse impact associated with strong seismic shaking is potential damage to structures and improvements. No habitable structures would be constructed as part of the proposed project; however, implementation of the proposed project would increase the use of the project site and result in the construction of improvements in areas subject to seismic shaking. The risk of ground shaking impacts is reduced through adherence to the design and materials standards set forth in building codes. Alameda County has adopted the 2022 California Building Code (Title 24, Part 2 of the California Code of Regulations [CBC]), which provides for stringent construction requirements on projects in areas of high seismic risk. The design and construction for the proposed project would be required to conform with, or exceed, current best standards for earthquake resistant construction in accordance with the most recent CBC adopted by the County and with the generally accepted standards of geotechnical practice for seismic design in Northern California.

Seismic design provisions of current building codes generally prescribe minimum lateral forces, applied statically to the structure, combined with the gravity forces of dead-and-live loads. The code-prescribed lateral forces are generally considered to be substantially smaller than the

³³ California Department of Conservation. 2019. Alquist-Priolo Earthquake Fault Zones. Website: www.conservation.ca.gov/cgs/alquist-priolo (accessed December 16 2022).

comparable forces that would be associated with a major earthquake. Therefore, structures would be able to: (1) resist minor earthquakes without damage, (2) resist moderate earthquakes without structural damage but with some nonstructural damage, and (3) resist major earthquakes without collapse but with some structural as well as nonstructural damage.

In addition, the Geotechnical Investigation Report completed for the proposed project includes design recommendations to manage potential concerns associated with strong seismic shaking, as well as recommendations for earthwork, foundations, retaining walls, interior slabs-on-grade, exterior concrete flatwork, pavements, site drainage, storm water runoff mitigation, and construction considerations. Compliance with the CBC and incorporation of the design recommendations identified in the project-specific geotechnical report would ensure potential impacts associated with strong seismic ground shaking would be reduced to a less-than-significant level. This impact would be less than significant.

iii. Seismic-related ground failure, including liquefaction? (Less-Than-Significant Impact)

Liquefaction is the transformation of loose, fine-grained sediment to a fluid-like state similar to quicksand. This phenomenon occurs due to strong seismic activity and lessens the soil's ability to support a structural foundation. The primary factors affecting the possibility of liquefaction in soil are: (1) intensity and duration of earthquake shaking; (2) soil type and relative density; (3) overburden pressures; and (4) depth to groundwater. Soil most susceptible to liquefaction is clean, loose, fine-grained sands and non-plastic silts that are saturated.

According to the California Geological Survey, the site is not located in a State-mapped geologic hazard zone for potential liquification. Further, the site-specific geotechnical report concluded that due to the composition, apparent relative density, and consistency of the soils, the presence of shallow bedrock, and the lack of free groundwater in the test pits, the potential for the project site to experience liquefaction-induced settlement during a design-level seismic event is very low.

Another type of seismically induced ground failure, which can occur as a result of seismic shaking, is dynamic compaction, or seismic settlement. This phenomenon typically occurs in unsaturated, loose granular material or uncompacted fill soils. Due to the composition, apparent relative density and consistency of the soils at the project site, the site-specific geotechnical report concluded that the potential for the project site to experience dynamic compaction/seismic settlement during a significant seismic event is low. In addition, conformance with the design recommendations described in the site-specific geotechnical report would ensure potential impacts associated with seismic ground failure, including liquefaction, would be less than significant.

v. Landslides? (Less-Than-Significant Impact)

A landslide generally occurs on relatively steep slopes and/or on slopes underlain by weak materials. Elevations on the project site range from approximately 340 to 420 feet and the site is underlain by approximately 0.5 to over 9 feet of alluvial soil deposits generally consisting of firm to hard sandy lean clay and clayey sand soils overlaying bedrock. According to the California Geological Survey, the project site is not located in a State-mapped geologic hazard zone for seismically induced landslides.

As referenced in the Geotechnical Investigation Report, two features in the southwest sloping hillside, northeast of the Perrich Avenue entrance, were determined to be small, past landslides. However, these features do not appear to pose a significant global instability impact to the overall project site. As outlined in Section 2.0, Project Description, the proposed project would include the use of fiber roll, jute netting and hydroseeded planting specified for steep, unirrigated slopes on the west side of the hill in the center of the site and in the northwest corner of the site to stabilize slopes. Implementation of the recommendations outlined in the Geotechnical Investigation Report, incorporation of slope stabilization measures into the proposed project, and compliance with the CBC during design and construction would ensure that the potential impacts associated with landslides would be less than significant.

b. Would the project result in substantial soil erosion or the loss of topsoil? (Less-Than-Significant Impact)

Topsoil is defined as the upper part of the soil profile that is relatively rich in humus and is technically known as the A-horizon of the soil profile.³⁴ The potential for soil erosion exists during the period of earthwork activities and between the time when earthwork is completed, and new vegetation is established, or hardscape is installed. Exposed soils could be entrained in stormwater runoff and transported off the project site. As part of construction activities, a total of 4 acres of soil would be disturbed during site grading. Because the proposed project would involve over 1 acre of land disturbance, it would be required to comply with the Construction General Permit,³⁵ which requires preparation and implementation of a Stormwater Pollution and Prevention Plan (SWPPP) prior to any ground disturbance activities. Although designed primarily to protect stormwater quality, the SWPPP would provide the details of the erosion control measures to be applied on the project site during the construction period, including Best Management Practices (BMPs) for erosion control that are recognized by the Regional Water Quality Control Board (RWQCB). Additional details regarding the SWPPP are provided in Section 4.10, Hydrology and Water Quality. Compliance with the requirements of the Construction General Permit would ensure that the proposed project would result in less than significant impacts related to soil erosion or the loss of topsoil.

c. Would the project be located on a geologic unit or soil that is unstable, or that would become unstable as a result of the project, and potentially result in on- or off-site landslide, lateral spreading, subsidence, liquefaction or collapse? (Less-Than-Significant Impact)

As discussed in Section 4.7.a, the site would not likely be subject to substantial adverse effects as a result of landslides or liquefaction.

Lateral spreading typically occurs as a form of horizontal displacement of relatively flat-lying alluvial material toward an open or “free” face such as an open body of water, channel, or excavation. In

³⁴ California State Mining and Geology Board. 2014. Surface Mining Reclamation Act Regulations. California Code of Regulations, Title 14, Division 2, Chapter 8, Subchapter 1.

³⁵ State Water Resources Control Board (SWRCB). 2009. Division of Water Quality. *Construction General Permit Fact Sheet*. 2009-0009-DWQ amended by 2010-0014-DWQ & 2012-0006-DWQ. Website: https://www.waterboards.ca.gov/water_issues/programs/stormwater/docs/constpermits/wqo_2009_0009_factsheet.pdf (accessed August 2022).

soils this movement is generally due to failure along a weak plane and may often be associated with liquefaction. As cracks develop within the weakened material, blocks of soil displace laterally towards the open face. Because the potential for liquefaction to occur at the project site is determined to be very low, the site-specific geotechnical report concluded that the potential for lateral spread to occur at the project site as a result of a future seismic event is low.

The proposed project would be designed and constructed in accordance with standard engineering practices and the CBC and would implement recommendations outlined in the geotechnical report. As such, the proposed project would not result in a geologic hazard from landslide, lateral spreading, subsidence, liquefaction or collapse. This impact would be less than significant.

d. Would the project be located on expansive soil, as defined in Table 18-1-B of the Uniform Building Code (1994), creating substantial direct or indirect risks to life or property? (Less-Than-Significant Impact)

Expansive soils are characterized by the potential for shrinking and swelling as the moisture content of the soil decreases and increases, respectively. Shrink-swell potential is influenced by the amount and type of clay minerals present and can be measured by the percentage of change in the soil volume. Based on soil testing conducted as part of the site-specific geotechnical report, soils at the project site have moderate to high expansion potential when subjected to changes in moisture content.

Expansive soil can change in volume with changes in moisture. It can shrink or swell and cause heaving and cracking of slabs-on-grade, pavements, and structures founded on shallow foundations. Building damage due to volume changes associated with expansive soil can be reduced by: (1) deepening conventional shallow footings to below the zone of significant seasonal moisture fluctuation, (2) using a rigid mat foundation that is designed to resist the settlement and heave of expansive soil, or (3) blanketing the footprint of the building pad with non-expansive soil.

As part of the site-specific geotechnical report, recommendations to mitigate the expansive soil behavior were given including deepening shallow foundations through the use of “non-expansive” fill beneath interior and exterior slabs, and moisture conditioning of the subgrade soils. Compliance with geotechnical recommendations and the CBC during design and construction would ensure that the potential impacts associated with expansive soils would be less than significant.

e. Would the project have soils incapable of adequately supporting the use of septic tanks or alternative waste water disposal systems where sewers are not available for the disposal of waste water? (No Impact)

The proposed project would be connected to existing wastewater collection and conveyance facilities owned and operated by the County. Therefore, septic tanks would not be necessary. Because the proposed project would not include the installation of septic tanks or alternative wastewater disposal systems, no impact would occur.

f. Directly or indirectly destroy a unique paleontological resource or site or unique geologic feature? (Less-Than-Significant with Mitigation Incorporated)

Although no paleontological resources or unique geological features are known to exist within or near the project site, the proposed project would require ground disturbance below ground surface. Therefore, the possibility of accidental discovery of paleontological resources during project construction cannot be discounted. Implementation of Mitigation Measure GEO-1, described below, would reduce potential impacts to paleontological resources to a less-than-significant level.

Mitigation Measure GEO-1 Should paleontological resources be encountered during project subsurface construction activities, all ground-disturbing activities within 25 feet shall be redirected and a qualified paleontologist contacted to assess the situation, consult with agencies as appropriate, and make recommendations for the treatment of the discovery. For purposes of this mitigation, a “qualified paleontologist” shall be an individual with the following qualifications: (1) a graduate degree in paleontology or geology and/or a person with a demonstrated publication record in peer-reviewed paleontological journals; (2) at least two years of professional experience related to paleontology; (3) proficiency in recognizing fossils in the field and determining their significance; (4) expertise in local geology, stratigraphy, and biostratigraphy; and (5) experience collecting vertebrate fossils in the field. If the paleontological resources are found to be significant and project activities cannot avoid them, measures shall be implemented to ensure that the project does not cause a substantial adverse change in the significance of the paleontological resource. Measures may include monitoring, recording the fossil locality, data recovery and analysis, a final report, and accessioning the fossil material and technical report to a paleontological repository. Upon completion of the assessment, a report documenting methods, findings, and recommendations shall be prepared and submitted to the County for review. If paleontological materials are recovered, this report also shall be submitted to a paleontological repository such as the University of California Museum of Paleontology, along with significant paleontological materials. Public educational outreach may also be appropriate.

Implementation of Mitigation Measure GEO-1 would reduce the level of the potential impact through the identification of paleontological resources during construction; the evaluation of unanticipated discoveries; and the recovery of significant paleontological data from those resources that warrant such investigation. This process would recover scientifically consequential information from at-risk resources to offset their potential loss. Therefore, with implementation of Mitigation Measure GEO-1, this impact would be less than significant.

4.8 GREENHOUSE GAS EMISSIONS

	Potentially Significant Impact	Less Than Significant with Mitigation Incorporated	Less Than Significant Impact	No Impact
Would the project:				
a. Generate greenhouse gas emissions, either directly or indirectly, that may have a significant impact on the environment?	<input type="checkbox"/>	<input type="checkbox"/>	<input checked="" type="checkbox"/>	<input type="checkbox"/>
b. Conflict with an applicable plan, policy or regulation adopted for the purpose of reducing the emissions of greenhouse gases?	<input type="checkbox"/>	<input type="checkbox"/>	<input checked="" type="checkbox"/>	<input type="checkbox"/>

Greenhouse gases (GHGs) are present in the atmosphere naturally, are released by natural sources, or are formed from secondary reactions taking place in the atmosphere. The gases that are widely seen as the principal contributors to human-induced global climate change are:

- Carbon dioxide (CO₂);
- Methane (CH₄);
- Nitrous oxide (N₂O);
- Hydrofluorocarbons (HFCs);
- Perfluorocarbons (PFCs); and
- Sulfur Hexafluoride (SF₆).

Over the last 200 years, humans have caused substantial quantities of GHGs to be released into the atmosphere. These extra emissions are increasing GHG concentrations in the atmosphere and enhancing the natural greenhouse effect, believed to be causing global warming. While manmade GHGs include naturally occurring GHGs such as CO₂, methane, and N₂O, some gases, like HFCs, PFCs, and SF₆ are completely new to the atmosphere.

Certain gases, such as water vapor, are short-lived in the atmosphere. Others remain in the atmosphere for significant periods of time, contributing to climate change in the long term. Water vapor is excluded from the list of GHGs above because it is short-lived in the atmosphere and its atmospheric concentrations are largely determined by natural processes, such as oceanic evaporation. For the purposes of this air quality analysis, the term “GHGs” will refer collectively to the six gases listed above.

These gases vary considerably in terms of Global Warming Potential (GWP), a concept developed to compare the ability of each GHG to trap heat in the atmosphere relative to another gas. The GWP is based on several factors, including the relative effectiveness of a gas to absorb infrared radiation and length of time that the gas remains in the atmosphere (“atmospheric lifetime”). The GWP of each gas is measured relative to CO₂, the most abundant GHG. The definition of GWP for a particular GHG is the ratio of heat trapped by one unit mass of the GHG to the ratio of heat trapped by one unit mass of CO₂ over a specified time period. GHG emissions are typically measured in terms of pounds or tons of “CO₂ equivalents” (CO₂e).

a. *Would the project generate greenhouse gas emissions, either directly or indirectly, that may have a significant impact on the environment? (Less-Than-Significant Impact)*

In April 2022, the BAAQMD adopted the Justification Report: CEQA Thresholds for Evaluating the Significance of Climate Impacts from Land Use Projects and Plans³⁶ document which identifies applicable GHG significance thresholds. The BAAQMD recommends these thresholds of significance for use in determining whether a proposed project will have a significant impact related to climate change. These thresholds evaluate a project based on its effect on California's efforts to meet long-term climate goals. Applying this approach, the BAAQMD identifies and provides supporting documentation outlining the requirements that new land use development projects must comply with in order to achieve California's long-term climate goal of carbon neutrality by 2045. Based on this research, the BAAQMD has determined that new land use development projects must incorporate specified design elements to contribute the "fair share" towards implementation of the goal of carbon neutrality by 2045. If a project is designed and built to incorporate the identified design elements, then it would contribute its portion of what is necessary to achieve California's long-term climate goals—its "fair share"—and an agency reviewing the project under CEQA can conclude that the project would not make a cumulatively considerable contribution to global climate change. The document concludes that if a project does not incorporate these design elements, then it should be found to result in a significant climate impact because it would hinder California's efforts to address climate change.

According to the Justification Report: CEQA Thresholds for Evaluating the Significance of Climate Impacts From Land Use Projects and Plans, a project would have a less than significant impact related to GHG emissions if it would:

- a. Include, at a minimum, the following project design elements:
 1. Buildings
 - a. The project will not include natural gas appliances or natural gas plumbing (in both residential and nonresidential development).
 - b. The project will not result in any wasteful, inefficient, or unnecessary electrical usage as determined by the analysis required under CEQA Section 21100(b)(3) and Section 15126.2(b) of the State CEQA Guidelines.
 2. Transportation
 - a. Achieve a reduction in project-generated vehicle miles traveled (VMT) below the regional average consistent with the current version of the California Climate Change Scoping Plan (currently 15 percent) or meet a locally adopted Senate Bill 743 VMT target, reflecting the recommendations provided in the Governor's Office of Planning and Research's *Technical Advisory on Evaluating Transportation Impacts in CEQA*:

³⁶ Bay Area Air Quality Management District (BAAQMD). 2022. *Justification Report: CEQA Thresholds for Evaluating the Significance of Climate Impacts From Land Use Projects and Plans*. April.

1. Residential projects: 15 percent below the existing VMT per capita
 2. Office projects: 15 percent below the existing VMT per employee
 3. Retail projects: no net increase in existing VMT
- b. Achieve compliance with off-street electric vehicle requirements in the most recently adopted version of CALGreen Tier 2.
- b. Or be consistent with a local GHG reduction strategy that meets the criteria under State CEQA Guidelines Section 15183.5(b).

Alameda County's Climate Action Plan meets the BAAQMD requirements for a Qualified GHG Reduction Strategy and is designed to streamline environmental review of future development projects in the County consistent with *State CEQA Guidelines* Section 15183.5(b) and the BAAQMD CEQA Air Quality Guidelines. However, the County's Climate Action Plan identifies emission reduction goals to reduce GHG emissions in Alameda County by 15 percent below the 2020 business-as-usual emissions level, consistent with Assembly Bill (AB) 32. The proposed project would not be operational until post-2020; therefore, because the County's Climate Action Plan was prepared based on the 2020 GHG targets, which are now superseded by the 2030 GHG targets established in SB 32, the County's Climate Action Plan would not apply for streamlining. Therefore, this section evaluates the proposed project's consistency with the BAAQMD's project design element thresholds.

Natural Gas Usage. According to the BAAQMD, a less than significant GHG impact would occur if the project does not include natural gas appliances or natural gas plumbing. Electricity and gas service is currently provided to the project site by Pacific Gas & Electric Company (PG&E). The proposed project would not include natural gas. Therefore, the proposed project would be consistent with this design element.

Energy Usage. The project must not result in any wasteful, inefficient, or unnecessary energy usage as determined by the analysis required under Section 21100(b)(3) and Section 15126.2(b) of the *State CEQA Guidelines*. Energy use consumed by the proposed project would be associated with electricity consumption and fuel used for vehicle trips associated with the project. Energy consumption was estimated for the project using default energy intensities by land use type in the CalEEMod output, which is included in Appendix A.

As discussed in Section 4.6, Energy, the estimated potential increased electricity demand associated with the proposed project is 5,151kWh per year. In 2021, Alameda County consumed 10,237 GWh or 10,237,401,835 kWh. Therefore, electricity demand associated with the proposed project would be less than 0.01 percent of Alameda County's total electricity demand.

In addition, the proposed project would result in energy usage associated with gasoline and diesel to fuel project-related trips. As discussed in Section 4.6, Energy, vehicle trips associated with the proposed project would consume approximately 28,435 gallons of gasoline per year and approximately 17,557 gallons of diesel fuel per year. Based on fuel consumption obtained from

CARB's EMFAC2021, approximately 569.1 million gallons of gasoline and approximately 160.2 million gallons of diesel will be consumed from vehicle trips in Alameda County in 2023. Therefore, gasoline and diesel fuel demand generated by vehicle trips associated with the proposed project would be a minimal fraction of gasoline and diesel fuel consumption in California.

As such, based on this analysis, as required under CEQA Section 21100(b)(3) and Section 15126.2(b) of the *State CEQA Guidelines*, the proposed project would not result in the wasteful, inefficient, or unnecessary consumption of fuel or energy and would incorporate renewable energy and energy efficiency measures into the building design, equipment use, and transportation. As such, the proposed project would be consistent with this design element.

Vehicle Miles Traveled. To meet the BAAQMD's VMT threshold, the project must achieve a reduction in project generated VMT below the regional average consistent with the current version of the California Climate Change Scoping Plan or meet a locally adopted SB 743 VMT target, reflecting the recommendations provided in the Governor's Office of Planning and Research's 2018 Technical Advisory on Evaluating Transportation Impacts in CEQA. As discussed in Section 4.17, Transportation, the proposed project would have a less-than-significant VMT impact. As such, the proposed project would be consistent with this design element.

Electric Vehicle Requirements. This criterion requires that the project achieve compliance with off-street electric vehicle requirements in the most recently adopted version of the California Green Building Standards Code (CALGreen) Tier 2 measures. The proposed project consists of a neighborhood park that is intended to serve existing nearby residents within walking and bicycling distance of the project site. As such, this design element is not applicable to the project.

As demonstrated above, the proposed project would be consistent with the BAAQMD's project design elements related to natural gas, energy, VMT, and electric vehicle requirements. Therefore, the proposed project would be consistent with the BAAQMD's GHG emission thresholds. As such, the proposed project would not generate significant GHG emissions that would have a significant effect on the environment, and this impact would be less than significant.

b. Would the project conflict with an applicable plan, policy or regulation adopted for the purpose of reducing the emissions of greenhouse gases? (Less-Than-Significant Impact)

As discussed above, Alameda County's Climate Action Plan identifies emission reduction goals to reduce GHG emissions in Alameda County by 15 percent below the 2020 business-as-usual emissions level, consistent with AB 32. The proposed project would not be operational until post-2020; therefore, because the County's Climate Action Plan was prepared based on the 2020 GHG targets, which are now superseded by the 2030 GHG targets established in SB 32, the County's Climate Action Plan would not apply for streamlining. However, the Climate Action Plan sets forth goals and measures to achieve emission reductions; therefore, a qualitative analysis of the proposed project's consistency with these policies and strategies is provided. These policies and other strategies include measures in transportation, land use, building energy, water, waste, and green infrastructure. Since the proposed project would develop a new park and would not include new buildings, many of the Climate Action Plan measures related to land use, building energy, and waste

wouldn't apply to the proposed project. The following measures are applicable to the proposed project:

- T-1: Improve bicycle infrastructure near community activity areas.
- T-4: Enhance pedestrian infrastructure within easy walking distance from community activity centers.
- T-5: Expand the traffic calming program to improve pedestrian safety.
- T-6: Improve pedestrian connectivity and route choice in neighborhoods.
- WT-2: Require new landscape projects to reduce outdoor potable water use by 40 percent.
- G-1: Expand the urban forest (e.g., street trees and trees on private lots) in order to sequester carbon and reduce building energy consumption.

The proposed project involves the construction of a new neighborhood park in Castro Valley, including new park facilities and associated improvements. The proposed project is not expected to result in a significant increase in the generation of vehicle trips or VMT. In addition, the project site is located within walking or cycling distance from the surrounding residential area and would promote the use of active and passive open space; therefore, the proposed project would support the applicable Climate Action Plan transportation measures. In addition, the primary goal of the landscaping plan is to maintain the site's open space character and increase its habitat value. As described above, vegetation at the project site consists primarily of non-native annual grassland with groves of native and non-native trees. As such, the proposed project would be consistent with applicable Climate Action Plan measures. Therefore, the proposed project would not conflict with any applicable plan, policy, or regulation adopted for the purpose of reducing the GHG emissions. This impact would be less than significant.

4.9 HAZARDS AND HAZARDOUS MATERIALS

	Potentially Significant Impact	Less Than Significant with Mitigation Incorporated	Less Than Significant Impact	No Impact
Would the project:				
a. Create a significant hazard to the public or the environment through the routine transport, use, or disposal of hazardous materials?	<input type="checkbox"/>	<input type="checkbox"/>	<input checked="" type="checkbox"/>	<input type="checkbox"/>
b. Create a significant hazard to the public or the environment through reasonably foreseeable upset and accident conditions involving the release of hazardous materials into the environment?	<input type="checkbox"/>	<input checked="" type="checkbox"/>	<input type="checkbox"/>	<input type="checkbox"/>
c. Emit hazardous emissions or handle hazardous or acutely hazardous materials, substances, or waste within one-quarter mile of an existing or proposed school?	<input type="checkbox"/>	<input type="checkbox"/>	<input type="checkbox"/>	<input checked="" type="checkbox"/>
d. Be located on a site which is included on a list of hazardous materials sites compiled pursuant to Government Code Section 65962.5 and, as a result, would it create a significant hazard to the public or the environment?	<input type="checkbox"/>	<input type="checkbox"/>	<input checked="" type="checkbox"/>	<input type="checkbox"/>
e. For a project located within an airport land use plan or, where such a plan has not been adopted, within 2 miles of a public airport or public use airport, would the project result in a safety hazard or excessive noise for people residing or working in the project area?	<input type="checkbox"/>	<input type="checkbox"/>	<input checked="" type="checkbox"/>	<input type="checkbox"/>
f. Impair implementation of or physically interfere with an adopted emergency response plan or emergency evacuation plan?	<input type="checkbox"/>	<input type="checkbox"/>	<input checked="" type="checkbox"/>	<input type="checkbox"/>
g. Expose people or structures, either directly or indirectly, to a significant risk of loss, injury or death involving wildland fires?	<input type="checkbox"/>	<input type="checkbox"/>	<input checked="" type="checkbox"/>	<input type="checkbox"/>

The following discussion is based on the findings of the Phase 1 Environmental Site Assessment (Phase I ESA)³⁷³⁸ prepared for the project site.

The Phase I ESA evaluated the potential for past land uses to have impacted the environmental condition of the site through the review of the following: regulatory records and files for the project site and surrounding area; historical topographic maps, historical aerial photography, and historical city directories; physical setting sources including the USGS 7.5 minute topographic maps and geology, hydrology, and soils maps of the project site and surrounding area; site reconnaissance to visually assess the potential for Recognized Environmental Conditions (RECs); and interviews with regulatory agencies and persons familiar with the project site. The site reconnaissance was limited to a visual observation of the project site and the Phase I ESA did not include any testing or sampling of materials, including soil, water, soil vapor, air, or building materials.

As described in the Phase I ESA, the earliest record reviewed was an 1899 historical topographic map that depicted the project site as undeveloped land. The project site remained undeveloped

³⁷ ACC Environmental Consultants. 2019. op. cit.

³⁸ The Phase 1 Environmental Site Assessment can be made available for review upon request to HARD.

until 1915. By 1939, the project site was developed with five structures (dwellings, storage structures, and barns) and an unpaved access road in the western portion of the site and two additional residential dwellings in the eastern portion of the project site. By 1949, the project site was developed with several structures (dwellings, storage structures, and barns) in the western portion of the site and three residential dwellings in the eastern portion of the project site, with unpaved roads providing access for these structures. The remainder of the site was developed for agricultural use. By 1958, additional dwellings, storage structures, and barns were developed on the project site with associated agricultural use. Between 1963 and 1968, agricultural operations had ceased and by 1991, all structures on the project site had been demolished.

Because the northwestern portion of the project site was historically used for agriculture, there is a potential that pesticides were applied during this time; however, there is no evidence indicating that pesticides were applied uniformly across the project site. The historical application of pesticides is considered a potential Business Environmental Risk (BER) if significant volumes of soil are disturbed and hauled off-site. If soils are disturbed as part of the proposed project actions, the ESA recommends that the soils be sampled for residual concentrations of pesticides and metals typically associated with historical pesticide use to determine the appropriate handling protocol. Further, subsurface sampling may be required by the Alameda County Department of Environmental Health (ACDEH) prior to development.

As part of the Phase I ESA, available environmental records and historical data were researched for the project site. A complete list of searched records and databases, as well as search distances, is attached in Appendix C. The database search indicated two mapped sites within a one-eighth-mile radius of the project site, however the assessment determined that no sites listed on the database report pose a significant concern to the project site. Additionally, the assessment did not reveal evidence of any RECs on the project site.

At the time of the site reconnaissance, visual inspection of the undeveloped areas, walkways, building foundations, and unpaved trails did not uncover evidence of hazardous materials, stains, or spills. In addition, no underground or aboveground storage tanks/records, violations of other indication of storage and/or use of hazardous materials associated with the project site were observed. No documented evidence of subsurface impacts that presents a potential vapor intrusion condition (pVIC) was present at the project site and the project site was identified as being in an area designed as Radon Zone 2.³⁹ Additionally, depth to first encountered groundwater was measured between 8.5 and 18 feet at the project site.

a. Would the project create a significant hazard to the public or the environment through the routine transport, use, or disposal of hazardous materials? (Less-Than-Significant Impact)

Construction. During construction of proposed park improvements, hazardous materials (e.g., fuel, oils, and paints) would be routinely transported, stored, and used at the project site. These materials are typical of materials delivered to construction sites. Transport and use of hazardous

³⁹ Radon Zone 2 is characterized as having predicted average indoor radon screening levels between two and four picocuries per liter of air (pCi/L) and is not considered significant based on the United States Environmental Protection Agency (US EPA) radon screening levels.

materials would be subject to all applicable State and federal laws, such as Hazardous Materials Transportation Act, the Resource Conservation and Recovery Act, the California Hazardous Materials Management Act, California Health and Safety Code, and California Code of Regulations Title 8 and Title 22.

Because the proposed project would result in soil disturbance greater than 1 acre, management of hazardous materials during construction activities would be subject to the requirements of the Stormwater Construction General Permit (described in detail under Section 4.10, Hydrology and Water Quality), which requires preparation and implementation of a Stormwater Pollution Prevention Plan (SWPPP) that includes hazardous materials storage requirements. For example, construction site operators must store chemicals in watertight containers (with appropriate secondary containment to prevent any spillage or leakage) or in a storage shed (completely enclosed). Compliance with existing regulations would ensure that the proposed project would not create a significant hazard to the public or the environment associated with the routine transport, use, or disposal of hazardous materials by ensuring these materials are properly handled during construction of the proposed project. This impact would be less than significant.

Operation. The proposed project would result in the development of a park. Normal operations would not introduce potentially hazardous materials. As outlined in Section 2.0, Project Description, some of the planting and turf areas would require typical maintenance such as fertilizer and irrigation. California law requires all facilities that use or store more than certain quantities of hazardous materials on-site to file hazardous materials business plans that list and map the location of onsite hazardous materials storage and use and that describe procedures in the event of an accident. However, HARD would be required to comply with existing governmental regulations in the use and disposal of these materials,⁴⁰ and such materials would not be used in sufficient strength or quantity to create a substantial risk to human or environmental health. Compliance with existing regulations would ensure that the proposed project would not create a significant hazard to the public or the environment associated with the routine transport, use, or disposal of hazardous materials by ensuring these materials are properly handled during operation of the proposed project. This impact would be less than significant.

b. Would the project create a significant hazard to the public or the environment through reasonably foreseeable upset and accident conditions involving the release of hazardous materials into the environment? (Less-Than-Significant with Mitigation Incorporated)

Construction. As described above, construction of the proposed project would require use of hazardous materials (e.g., oils, fuels, solvents, paints) associated with construction of proposed park improvements. An accidental release of these hazardous materials during project construction could result in exposure of construction workers, the public, and/or the environment to hazardous materials. However, HARD would be required to comply with existing government regulations during the use and disposal of these materials, and such materials would not be used in sufficient strength or quantity to create a substantial risk to human or environmental health.

⁴⁰ The United States Environmental Protection Agency regulates “small-quantity generators” (SQGs) of hazardous wastes, which are defined as facilities that generate more than 100 kg (approximately 220 lbs), but less than 1,000 kg (2,200 lbs), of hazardous waste per month.

As discussed above, hazardous materials most likely to be used during construction include typical construction materials such as gasoline, diesel, motor oil, lubricants, solvents, and adhesives. Drips and small spills would be the most likely potential hazardous materials releases to occur, however any release that occurs in close proximity to a stream or drainage channel could have a significant impact on the environment, if not properly controlled. Preparation and proper implementation of a SWPPP in accordance with the NPDES General Permit for Storm Water Discharges Associated with Construction and Land Disturbance Activities (NPDES General Construction Permit)(Order No. 2009-0009-DWQ, NPDES No. CAS000002) (SWRCB, 2009) permitting requirements would reduce the potential for hazardous materials releases to occur during construction, and would reduce the potential for spills to impact sensitive habitat or human health, to less than significant. SWPPPs are required for construction sites over one acre that do not qualify for a waiver.

Because the project site was historically used for agriculture, there is a potential that pesticides were applied during this time; however, there is no evidence indicating that pesticides were applied uniformly across the project site. The historical application of pesticides is considered a potential BER if significant volumes of soil are disturbed and hauled off-site. As such, construction activities at the project site have the potential to create a hazard to the public and environment through reasonably foreseeable upset and accident conditions associated with the potential contaminants in on-site soils. Implementation of the following mitigation measure, which requires that soils be sampled for residual concentrations of pesticides and metals prior to disturbance, would reduce potential impacts associated with the accidental release of hazardous materials into the environment to a less-than-significant level.

Mitigation Measure HAZ-1: Prior to the ground disturbing activities, HARD shall conduct a limited subsurface investigation of the site, which would include soil sampling of surficial soils to evaluate if potentially hazardous constituents are present in shallow soils that would be disturbed. The samples shall be analyzed for contaminants of potential concern (COPCs), including arsenic from pesticides, petroleum hydrocarbons (gasoline, diesel, and motor oil), and organochlorine pesticides (OCP), and volatile organic compounds (VOCs). If contaminated soils are found in concentrations above established thresholds for worker safety, a Site Management Plan (SMP) shall be prepared by a qualified hazardous materials consultant to establish management practices for handling contaminated soil or other materials encountered during construction activities.

Operation. The proposed project would not involve storage or use of hazardous materials (except for small quantities for landscape maintenance as described above) or generation of significant hazardous wastes. As such, potential significant impacts related to a foreseeable upset associated with operation of the proposed park would not be expected. This impact would be less than significant.

c. Would the project emit hazardous emissions or handle hazardous or acutely hazardous materials, substances, or waste within one-quarter mile of an existing or proposed school? (No Impact)

No schools are located within one-quarter mile of the proposed project. Several schools are located within one-half mile of the project site including: Redwood High School located at 18400 Clifton Way approximately 0.4 miles northeast of the project site, Stanton Elementary School located at 2644 Somerset Avenue approximately 0.3 miles southeast of the project site, Chabot Elementary School located at 19104 Lake Chabot Road approximately 0.3 miles east of the project site, and Mission Hills School Castro Valley located at 2330 Pomar Vista Avenue approximately 0.5 miles south of the project site. Because these distances are greater than one-quarter mile, the proposed project would not emit hazardous emission or handle hazardous materials within one-quarter mile of an existing or proposed school. No impact would occur.

d. Would the project be located on a site which is included on a list of hazardous materials sites compiled pursuant to Government Code Section 65962.5 and, as a result, would it create a significant hazard to the public or the environment? (Less-Than-Significant Impact)

Government Code Section 65962.5 requires the California Environmental Protection Agency (CalEPA) to develop, at least annually, an updated list of hazardous materials release sites known as the Cortese List. As part of the Phase I ESA, available environmental records and historical data were researched for the project site. A complete list of searched records and databases, as well as search distances, is attached in Appendix C. The database search indicated that the project site is not listed on any regulatory databases. Two mapped sites within a one-eighth-mile radius of the project site were identified, however the assessment determined that no sites listed on the database report pose a significant concern to the project site. Additionally, the Phase I ESA did not uncover evidence of RECs on the project site. As such, the proposed project would not create a significant hazard to the public or the environment as a result of being located on a list of hazardous materials site compiled pursuant to Government Code Section 65962.5. Impacts would be less than significant.

e. Would the project be located within an airport land use plan or, where such a plan has not been adopted, within 2 miles of a public airport or public use airport, would the project result in a safety hazard or excessive noise for people residing or working in the project area? (No Impact)

According to the Castro Valley Area General Plan, Castro Valley is not located within two miles of a private or public airstrip or within an area covered by an airport land use plan. The closest airports to the project site are the Hayward Executive Airport, located approximately 3.5 miles southwest of the project site and the Oakland International Airport located approximately 6 miles northwest of the project site. The proposed project would include development of a community park with recreation uses. Proposed improvements would be largely at-grade. The proposed project would not increase residential density, would not be an incompatible land use, would not increase the height of improvements such that it would create a hazard or obstruction, and would not result in the addition of a characteristic that would create a hazard to air navigation. Therefore, no impact related to airport safety hazards would occur.

f. Would the project impair implementation of or physically interfere with an adopted emergency response plan or emergency evacuation plan? (Less-Than-Significant Impact)

The Alameda County Emergency Operations Center (EOC) is coordinated and maintained by the Alameda County Sheriff's Office of Emergency Services (OES). Alameda County OES coordinates county-wide emergency response efforts including the preparation and implementation of the Alameda County Emergency Operations Plan (EOP)⁴¹ and the Alameda County Local Hazard Mitigation Plan.⁴² However, the EOP does not indicate the specific emergency evacuation routes within Alameda County. The proposed project would construct a community park within an existing residential neighborhood. The proposed project would be consistent with the policies outlined in the Alameda County General Plan Safety Element and the *Castro Valley General Plan* Natural Hazards and Public Safety Element.

The proposed project would not alter or block adjacent roadways, and implementation of the proposed project would not be expected to impair the function of nearby roadways that might be used for evacuation during an emergency. In addition, operation of the proposed project would not cause permanent alterations to vehicle circulation routes and patterns or impede public access or travel upon public rights-of-way. Prior to approval of final maps and improvement plans for any development project within Castro Valley, plan review and approval by the Alameda County Fire District is required. Proposed ingress/egress for the proposed park would be required to meet State and local standards regarding turning radius, road width, and emergency vehicle access. Adherence to the emergency access measures required by the County would ensure that impacts related to implementation of or physical interference with an adopted emergency response plan or emergency evacuation plan would be less than significant.

g. Would the project expose people or structures, either directly or indirectly, to a significant risk of loss, injury or death involving wildland fires? (Less-Than-Significant Impact)

In Castro Valley, the areas with the greatest wildfire risk edge the community to the north, east, and south where residential neighborhoods border undeveloped wooded or grassy areas. State law requires the California Department of Forestry and Fire Protection to designate Very High Fire Severity Zones based on the potential threat from wildfire hazards. The zones include areas where the responsibility for preventing and suppressing fires is primarily the responsibility of the State and areas where local agencies are responsible for fire protection. According to the Castro Valley Area General Plan, the project site is located in a Local Responsibility Area (LRA) Very High Fire Severity Zone (VHFSZ).

In areas of high fire hazard, the risk to structures from fire exposure is based on the materials with which they are built and proximity to field sources, such as trees, shrubs, wooden decks and fences, and woodpiles. The proposed project includes the development of a community park on an undeveloped site within an existing residential community. The proposed project does not involve

⁴¹ Alameda County Sheriff's Office of Homeland Security and Emergency Services. 2012. *Alameda County Emergency Operation Plan*. Available online at: www.acgov.org/ready/documents/EmergencyOperationsPlan.pdf. (Accessed January 12, 2023).

⁴² Alameda County. 2016b. *County of Alameda 2016 Local Hazard Mitigation Plan*. October.

construction of residential or commercial structures or any other structures for human occupation and people would use the park for a limited duration of time. Wildfire risks at the site would be minimized due to the surrounding residential uses, however, vegetation across the project site could pose a wildfire risk during the summer and fall. The County Public Works Agency uses an Integrated Vegetation Management Program to control plants that may pose a fire danger, obstruct drainage water, or interfere with maintenance of County facilities. In addition, Chapter 6.44 of the County's General ordinance prohibits vegetation that may increase fire hazards. The proposed project's landscape plan would adhere to these vegetation regulations.

The proposed project is required to be designed in compliance with all applicable State and local standards and recommendations for new development. In addition, the project would be required to comply with the 2022 California Fire Code, which calls for the installation, maintenance, and ongoing inspection of fire protection systems under the direction of the local Fire Chief. In addition, the Fire Code authorizes the Fire Chief to specify water supply and road design standards. Prior to approval of final maps and improvement plans for any development project within the Castro Valley area, plan review and approval by the Alameda County Fire Department is required. Further, coordination with the Alameda County Fire Department would determine the measures that would be implemented to reduce the risk for fire and ensure adequate access for fire equipment and personnel.

The proposed project would also be subject to requirements in Section 13000 et seq. of the California Health and Safety Code, the California Building Standards Code, and the California State Fire Code, which include regulations concerning the following: building standards for fire protection; fire protection and notification systems such as extinguishers and smoke alarms; safety for firefighters and emergency responders during emergency operations; minimum standards for hazardous vegetation and fuel management, defensible space, and building construction; and minimum standards for emergency access and water supply for fire response.

Compliance with these existing regulatory requirements would reduce impacts related to the exposure of people or structures, either directly or indirectly, to a significant risk of loss, injury or death involving wildland fires to a less-than-significant level.

4.10 HYDROLOGY AND WATER QUALITY

	Potentially Significant Impact	Less Than Significant with Mitigation Incorporated	Less Than Significant Impact	No Impact
Would the project:				
a. Violate any water quality standards or waste discharge requirements or otherwise substantially degrade surface or groundwater quality?	<input type="checkbox"/>	<input type="checkbox"/>	<input checked="" type="checkbox"/>	<input type="checkbox"/>
a. Substantially decrease groundwater supplies or interfere substantially with groundwater recharge such that the project may impede sustainable groundwater management of the basin?	<input type="checkbox"/>	<input type="checkbox"/>	<input checked="" type="checkbox"/>	<input type="checkbox"/>
b. Substantially alter the existing drainage pattern of the site or area, including through the alteration of the course of a stream or river or through the addition of impervious surfaces, in a manner which would:	<input type="checkbox"/>	<input type="checkbox"/>	<input checked="" type="checkbox"/>	<input type="checkbox"/>
i. Result in substantial erosion or siltation on- or off-site;	<input type="checkbox"/>	<input type="checkbox"/>	<input checked="" type="checkbox"/>	<input type="checkbox"/>
ii. Substantially increase the rate or amount of surface runoff in a manner which would result in flooding on- or offsite;	<input type="checkbox"/>	<input type="checkbox"/>	<input checked="" type="checkbox"/>	<input type="checkbox"/>
iii. Create or contribute runoff water which would exceed the capacity of existing or planned stormwater drainage systems or provide substantial additional sources of polluted runoff; or	<input type="checkbox"/>	<input type="checkbox"/>	<input checked="" type="checkbox"/>	<input type="checkbox"/>
iv. Impede or redirect flood flows?	<input type="checkbox"/>	<input type="checkbox"/>	<input type="checkbox"/>	<input checked="" type="checkbox"/>
c. In flood hazard, tsunami, or seiche zones, risk release of pollutants due to project inundation?	<input type="checkbox"/>	<input type="checkbox"/>	<input type="checkbox"/>	<input checked="" type="checkbox"/>
d. Conflict with or obstruct implementation of a water quality control plan or sustainable groundwater management plan?	<input type="checkbox"/>	<input type="checkbox"/>	<input checked="" type="checkbox"/>	<input type="checkbox"/>

a. *Would the project violate any water quality standards or waste discharge requirements or otherwise substantially degrade surface or groundwater quality? (Less-than-Significant Impact)*

The SWRCB and nine Regional Water Quality Control Boards regulate the quality of surface water and groundwater bodies throughout California. In the Bay Area, including the project site, the San Francisco Bay Regional Water Quality Control Board (Water Board) is responsible for implementation of the Water Quality Control Plan (Basin Plan). The Basin Plan establishes beneficial water uses and water quality objectives for waterways and water bodies within the region. Section 303(d) of the federal Clean Water Act (CWA) requires that states identify water bodies including bays, rivers, streams, creeks, and coastal areas that do not meet water quality standards and the pollutants that are causing the impairment. Total Maximum Daily Loads (TMDLs) describe the maximum amount of a pollutant that a water body can receive while still meeting established water quality standards. A TMDL establishes limits for pollutant discharges into impaired water bodies. Stormwater from the project site discharges to San Lorenzo Creek and the San Francisco Bay.⁴³ The State Water Resources Control Board Surface Water Quality Assessment 2020-2022 Integrated Report for Clean Water Act Sections 303(d) and 305(b) lists San Lorenzo Creek as impaired for

⁴³ Alameda County Community Development Agency. 2012. *Castro Valley General Plan, Chapter 9 Public Services and Utilities*. March.

diazinon. The Lower San Francisco Bay is listed as an impaired water body for the following pollutants: dichlorodiphenyltrichloroethane (DDT), dioxin compounds, furan compounds, polychlorinated biphenyls (PCBs) (dioxin-like), dieldrin, trash, PCBs, mercury, invasive species, and chlordane.⁴⁴

Runoff water quality is regulated by the NPDES Program (established through the federal CWA). The NPDES program objective is to control and reduce pollutant discharges to surface water bodies. Compliance with NPDES permits is mandated by State and federal statutes and regulations. Locally, the NPDES Program is administered by the Water Board. According to the water quality control plans of the Water Board, any construction activities, including grading, that would result in the disturbance of 1 acre or more would require compliance with SWRCB's CGP,⁴⁵ which requires preparation of a SWPPP and implementation of Construction BMPs during construction activities. Construction BMPs would include, but not be limited to, Erosion Control and Sediment Control BMPs designed to minimize erosion and retain sediment on site and Good Housekeeping BMPs to prevent spills, leaks, and discharge of construction debris and waste into receiving waters.

The proposed project would be subject to the California Regional Water Quality Control Board San Francisco Bay Region's Municipal Regional Stormwater NPDES Permit (MRP), which went into effect on July 1, 2022 by Order R2-2022-0018, NPDES Permit No. CAS612008. The MRP covers stormwater discharges from municipalities and local agencies in Alameda, Contra Costa, San Mateo, and Santa Clara counties, and the cities of Fairfield, Suisun City, Vallejo, and the Vallejo Flood & Wastewater District, which have joined together to form the Solano Stormwater Alliance. Provision C.3 of the MRP requires new development and redevelopment projects that would replace or develop more than 5,000 square feet of impervious surfaces to include post-construction stormwater control in project designs. Under the Provision C.3 requirements, the preparation and submittal of a Stormwater Control Plan (SCP) would be required. The purpose of an SCP is to detail the design elements and implementation measures necessary to meet the post-construction stormwater control requirements of the MRP. In particular, SCPs must include Low Impact Development (LID) design measures, which reduce water quality impacts by preserving and recreating natural landscape features, minimizing imperviousness, and using stormwater as a resource, rather than a waste product. Additionally, the preparation of a Stormwater Facility Operation and Maintenance Plan is required to ensure that stormwater control measures are inspected, maintained, and funded for the life of the project.

Construction. The proposed project includes the development of a new neighborhood park that would include active and passive open space, paved and earthen walking trails, play structures, picnic areas, prefabricated restrooms, picnic areas, landscaping, and parking. Construction of the proposed project would result in the disturbance of approximately 4 acres of land. Pollutants of

⁴⁴ State Water Resources Control Board. 2023. *2020-2022 California Integrated Report (Clean Water Act Section 303(d) List and 305(b) Report)*. Website: https://www.waterboards.ca.gov/water_issues/programs/water_quality_assessment/2018_integrated_report.html (accessed September 2022).

⁴⁵ State Water Resources Control Board. 2022. National Pollutant Discharge Elimination System (NPDES) General Permit for Stormwater Discharges Associated with Construction and Land Disturbance Activities (Order No. 2022-0057-DWQ, NPDES No. CAS000002)

concern during construction include sediments, trash, petroleum products, concrete waste (dry and wet), sanitary waste, and chemicals. Each of these pollutants on its own or in combination with other pollutants can have a detrimental effect on water quality. During construction activities, excavated soil would be exposed, and there would be an increased potential for soil erosion and sedimentation compared to existing conditions. In addition, chemicals, liquid products, petroleum products (e.g., paints, solvents, and fuels), and concrete-related waste may be spilled or leaked, and they have the potential to be transported via stormwater runoff into receiving waters.

Because construction of the proposed project would disturb greater than 1 acre of soil, the project is subject to the requirements of the CGP, which requires preparation of a SWPPP and implementation of construction BMPs during construction activities. Construction BMPs would include, but are not limited to, Erosion Control and Sediment Control BMPs designed to minimize erosion and retain sediment on site and Good Housekeeping BMPs to prevent spills, leaks, and discharge of construction debris and waste into receiving waters. BMP implementation shall be consistent with the BMP requirements in the most recent version of the California Stormwater Quality Association's Stormwater Best Management Handbook: Construction. The SWPPP would also include a construction site monitoring program that identifies requirements for dry weather visual observations of pollutants at all discharge locations, and as appropriate (depending on the Risk Level), sampling of the site effluent and receiving waters. A Qualified SWPPP Practitioner will be responsible for implementing the BMPs at the site and performing all required monitoring and inspection/maintenance/repair activities.

As required, HARD would obtain coverage under the CGP, including submission of Permit Registration Documents (PRDs), including a Notice of Intent for coverage under the permit to the State Water Resources Control Board (SWRCB) via the Stormwater Multiple Application and Report Tracking System (SMARTs). HARD will provide the Waste Discharge Identification Number (WDID) to the Planning Manager of Alameda County Community Development Agency or designee, to demonstrate proof of coverage under the Construction General Permit. Project construction will not be initiated until a WDID is received from the SWRCB and is provided to the County. Upon completion of construction and stabilization of the site, a Notice of Termination shall be submitted via SMARTs.

Additionally, the preparation and implementation of erosion and sediment control plans would be required per Section 15.36.620 of the Alameda County Municipal Code which would include measures to prevent increased discharge of sediment at all stages of grading and development from initial disturbance of the ground to project completion and detailed cross-reference to each element of the SWPPP, including the planned BMP's and descriptions of the required monitoring programs. Erosion and sediment control plans shall include an effective revegetation program to stabilize all disturbed areas that will not be otherwise protected.

According to the Geotechnical Investigation Report⁴⁶ completed for the proposed project, it is anticipated that groundwater at the project site is deeper than 20 feet below ground surface. However, groundwater levels can fluctuate several feet depending on factors such as seasonal rainfall, groundwater withdrawal, and construction activities on the project site or at adjacent

⁴⁶ BSK Associates, 2020. op. cit.

properties. Construction of the proposed project would require excavation for utility lines, storm drains, fence footings, shade structures, playground equipment footings, and stormwater swales. Therefore, dewatering of groundwater may be required during construction activities involving excavation. Release of dewatered groundwater to surface waters can introduce total dissolved solids and other constituents to surface waters and could cause degradation of the receiving water quality. In the event that groundwater is encountered during construction and groundwater dewatering is necessary, any groundwater dewatering during excavation would be conducted in accordance with the requirements of the CGP, which allows the discharge of dewatering effluent if the source of the water is uncontaminated groundwater and is properly filtered or treated, using appropriate technology.

Adherence with the CGP, including implementation of the required SWPPP, Construction BMPs, and dewatering requirements in addition to compliance with the Alameda County Municipal Code, including preparation of erosion and sediment control plans, would ensure construction impacts related to surface water quality standards, waste discharge requirements, and surface water quality would be less than significant.

Operation. Pollutants of concern from long-term operations include pathogens (bacteria/viruses), metals, nutrients, motor vehicle lubricants, toxic organic compounds, pesticides/herbicides, sediments/total suspended solids, trash and debris, and oil and grease. Castro Valley is under of the purview of the MRP. Therefore, the proposed project would be subject to the requirements of Provision C.3 of the MRP because the project would develop more than 5,000 square feet of impervious surfaces. In compliance with Provision C.3 of the MRP, HARD would be required to prepare an implement an SCP, including a Stormwater Facility Operation and Maintenance Plan, would be required. The SCP would act as the overall program document designed to provide measures to mitigate potential water quality impacts associated with the operation of the proposed project. The SCP will be prepared in accordance with the requirements and guidelines set forth in the Alameda Clean Water Program C3 Technical Guidance Manual.

Additionally, HARD would be required obtain a stormwater permit from the Alameda County Director of Public Works as required by Article IV, Section 13.08.250 of the Alameda County Municipal Code. The proposed project would include rock and earthen swales that would be used for stormwater control, infiltration, and treatment to reduce pollutants of concern in stormwater prior to release into the storm drain system. Therefore, compliance with the requirements of the MRP and Alameda County Municipal Code would ensure that operational impacts to water quality would be less than significant.

Overall, because the proposed project would be required to comply with existing regulations including the CGP, the MRP, and Alameda County Municipal Code requirements, the proposed project would not violate any water quality standards or waste discharge requirements or otherwise substantially degrade surface or groundwater quality. Impacts would be less than significant.

b. Would the project substantially decrease groundwater supplies or interfere substantially with groundwater recharge such that the project may impede sustainable groundwater management of the basin? (Less-than-Significant Impact)

The project site is not located within a mapped Division of Water Rights groundwater basin boundary.⁴⁷ Impacts related to groundwater recharge are discussed below. **Construction.** Temporary dewatering from isolated areas of deeper excavation may be necessary during construction. However, such dewatering would be localized and temporary and would not result in the lowering of surrounding groundwater levels. **Operation.** Water supply to the proposed project would be provided by the East Bay Municipal Utility District (EBMUD) water system, which is supplied from the Mokelumne River.⁴⁸ Because EBMUD does not use groundwater for municipal water supply, water use during operation of the proposed project would not affect groundwater.

Development of the proposed project would result in an increase in impervious surfaces on the project site which could reduce groundwater recharge compared to existing conditions. However, in compliance with the MRP and the Alameda County Municipal Code, the proposed project would include rock and earthen swales that would be used for stormwater control, infiltration, and treatment. Due to the incorporation of infiltration basins and the implementation of LID techniques as required by the MRP and Alameda County Municipal Code, the proposed project would not result in a significant decrease in groundwater recharge that would result in a net deficit in aquifer volume or a lowering of the local groundwater table level. Therefore, the proposed project would not interfere with groundwater recharge.

For the reasons listed above, impacts related to the decrease of groundwater supplies or interference with groundwater recharge would be less than significant.

c. Would the project substantially alter the existing drainage pattern of the site or area, including through the alteration of the course of a stream or river or through the addition of impervious surfaces, in a manner which would:

i. Result in substantial erosion or siltation on- or off-site; (Less-Than-Significant Impact)

During construction activities, more than 1 acre of soil would be disturbed. Soil would be exposed and drainage patterns would be temporarily altered during grading and other construction activities, and there would be an increased potential for soil erosion and siltation compared to existing conditions. Additionally, during a storm event, soil erosion and siltation could occur at an accelerated rate. Compliance with the CGP requires the preparation of a SWPPP to identify construction BMPs to be implemented as part of the proposed project to reduce impacts on water quality during construction, including those impacts associated with soil erosion and siltation. Additionally, the preparation and implementation of erosion and sediment control plans would be required per Section 15.36.620 of the Alameda County Municipal Code which would include

⁴⁷ State of California Department of Water Resources (DWR). DWR Mapping Tool. Website: <https://sgma.water.ca.gov/webgis/index.jsp?appid=gasmaster&rz=true> (accessed March 2023).

⁴⁸ East Bay Municipal Utility District (EBMUD). 2021a. Water Supply. Website: www.ebmud.com/water/about-your-water/water-supply (accessed August 2022)

measures to prevent increased discharge of sediment at all stages of grading and development from initial disturbance of the ground to project completion. With compliance with the requirements in the CGP, Alameda Municipal Code, and implementation of construction BMPs, construction impacts related to on- or off-site erosion or siltation would be less than significant.

After the completion of project construction, operation of the proposed project would result in an increase in impervious surfaces on the project site that would result in a net increase in stormwater runoff that can lead to downstream erosion in receiving waters. However, as discussed above, the rock and earthen swales included in the project's design in compliance with the MRP would be used for stormwater control, infiltration, and treatment. Due to the incorporation of infiltration basins and the implementation of LID techniques as required by the MRP and Alameda County Municipal Code, operational impacts related to on- or off-site erosion or siltation would be less than significant.

ii. Substantially increase the rate or amount of surface runoff in a manner which would result in flooding on- or offsite; (Less-Than-Significant Impact)

Development of the proposed project would result in an increase in impervious surfaces on the project site that could have the potential to increase the volume and rate of stormwater runoff discharged from the project site. However, as previously discussed, the rock and earthen swales included in the project's design in compliance with the MRP would be used for stormwater control, infiltration, and treatment. The proposed drainage facilities and BMPs needed to accommodate stormwater runoff would be appropriately sized so that on-site flooding would not occur. Therefore, due to the implementation of LID techniques as required by the MRP and Alameda County Municipal Code, the proposed project would not substantially increase the rate or amount of surface runoff in a manner that would result in flooding on- or off site. Impacts would be less than significant.

iii. Create or contribute runoff water which would exceed the capacity of existing or planned stormwater drainage systems or provide substantial additional sources of polluted runoff; or (Less-Than-Significant Impact)

Under existing conditions, stormwater drainage from the site has been addressed through a variety of techniques implemented by adjacent property owners. Because the proposed site plan would involve minimal changes to existing drainage patterns, only certain areas would require comprehensive stormwater management. Storm drain connections would be developed along both vehicular access points and permeable surfacing and swales would be used to support stormwater control, infiltration, and treatment, prior to the discharge of stormwater to County-maintained storm drains. The proposed project would be required to comply with the MRP and Alameda County Municipal Code and would include the incorporation of LID design features. The proposed drainage facilities and BMPs needed to accommodate stormwater runoff would be appropriately sized such that drainage facility capacity would not be exceeded during a design storm. Therefore, the proposed project would not result in an exceedance of planned or existing stormwater drainage systems and impacts would be less than significant.

As discussed in Section 4.10.a, pollutants of concern during construction include sediments, trash, petroleum products, concrete waste (dry and wet), sanitary waste, and chemicals, and each of these pollutants on its own or in combination with other pollutants can have a detrimental effect on water quality. Drainage patterns would be temporarily altered during grading and other construction activities, and construction-related pollutants could be spilled, leaked, or transported via storm runoff into adjacent drainages and downstream receiving waters. However, as previously discussed, the proposed project would be required to comply with the requirements set forth by the CGP and SWPPP, which would specify BMPs to be implemented to control the discharge of pollutants in stormwater runoff as a result of construction activities. Additionally, the preparation and implementation of erosion and sediment control plans would be required per Section 15.36.620 of the Alameda County Municipal Code which would include measures to prevent increased discharge of sediment at all stages of grading and development from initial disturbance of the ground to project completion. With compliance with the requirements in the CGP, Alameda Municipal Code, and implementation of construction BMPs, construction impacts related to on- or off-site erosion or siltation would be less than significant.

Expected pollutants of concern from long-term operations include pathogens (bacteria/viruses), metals, nutrients, motor vehicle lubricants, coolants, disc brake dust, toxic organic compounds, pesticides/herbicides, sediments/total suspended solids, trash and debris, and oil and grease. As previously discussed, compliance with the MRP and Alameda County Municipal Code and the implementation of LID techniques would ensure that the proposed project would not discharge substantial sources of polluted runoff from the project site. Operation-related impacts would be less than significant.

iv. Impede or redirect flood flows? (Less-Than-Significant Impact)

The project site is not located within a Federal Emergency Management Agency (FEMA) designated 100-year or 500-year floodplain.⁴⁹ According to FEMA Flood Insurance Rate Map (FIRM) No. 06001C0278G, the project site is located within Zone X, defined as an area of minimal flood hazard.⁵⁰ As the proposed project would not place improvements and structures directly within a 100-year floodplain, the project would not impede or redirect flood flows, and there would be no impact.

⁴⁹ Alameda County Community Development Agency. 2012. *Castro Valley General Plan*, Chapter 10, Natural Hazards and Public Safety. March.

⁵⁰ Federal Emergency Management Agency (FEMA), 2009. Flood Insurance Rate Map (FIRM) No. 06001C0278G, effective August 3. Website: <https://msc.fema.gov/portal/search?AddressQuery=sydney%20way%2C%20castro%20valley%2C%20ca#searchresultsanchor> (accessed March 21, 2023).

d. In flood hazard, tsunami, or seiche zones, would the project risk release of pollutants due to project inundation? (No Impact)

The project site is not located within a Federal Emergency Management Agency (FEMA) designated 100-year or 500-year floodplain.⁵¹ According to FEMA Flood Insurance Rate Map (FIRM) No. 06001C0278G, the project site is located within Zone X, defined as an area of minimal flood hazard.⁵² The project site is not located in an area mapped by the California Emergency Management Agency as being potentially inundated by a tsunami.⁵³ Seiches are waves that are created in an enclosed body of water such as a bay, lake, or harbor and go up and down or oscillate and do not progress forward like standard ocean waves. The nearest enclosed water body is Lake Chabot, located approximately 0.65 mile north of the project site. Due to distance and elevation differences between Lake Chabot and the project site, the project site would not be inundated in the event of a seiche. Therefore, there would be no impacts related to the release of pollutants in the event of inundation due to flood hazard, tsunamis, or seiches.

e. Would the project conflict with or obstruct implementation of a water quality control plan or sustainable groundwater management plan? (Less Than Significant Impact)

In the Bay Area, including the project site, the Water Board is responsible for implementation of the Basin Plan, which establishes beneficial water uses for waterways and water bodies within the region. As previously discussed, the proposed project would comply with existing NPDES permit requirements, including the CGP and MRP, and would implement construction and operational BMPs to reduce pollutants of concern in stormwater runoff. Compliance with these regulatory requirements would ensure that the proposed project would not degrade or alter water quality, causing the receiving waters to exceed the water quality objectives, or impair the beneficial use of receiving waters. As such, the proposed project would not result in water quality impacts that would conflict with the Basin Plan. Construction and operational impacts related to a conflict with the Basin Plan would be less than significant.

The project site is not located within a mapped Division of Water Rights groundwater basin boundary and is not subject to a sustainable groundwater management plan. Nevertheless, the proposed project would not interfere with groundwater recharge in the vicinity of the project site as discussed in Section 4.10.b. Therefore, the proposed project would not conflict with or obstruct the implementation of a sustainable groundwater management plan, and this impact would be less than significant.

⁵¹ Alameda County Community Development Agency. 2012. *Castro Valley General Plan*, Chapter 10, Natural Hazards and Public Safety. March.

⁵² Federal Emergency Management Agency (FEMA), 2009. op. cit.

⁵³ California Department of Conservation (DOC). *Alameda County Tsunami Hazard Areas*. Website: <https://www.conservation.ca.gov/cgs/tsunami/maps/alameda> (accessed March 21, 2023).

4.10 LAND USE AND PLANNING

	Potentially Significant Impact	Less Than Significant with Mitigation Incorporated	Less Than Significant Impact	No Impact
Would the project:				
a. Physically divide an established community?	<input type="checkbox"/>	<input type="checkbox"/>	<input checked="" type="checkbox"/>	<input type="checkbox"/>
b. Cause a significant environmental impact due to a conflict with any land use plan, policy, or regulation adopted for the purpose of avoiding or mitigating an environmental effect?	<input type="checkbox"/>	<input type="checkbox"/>	<input checked="" type="checkbox"/>	<input type="checkbox"/>

a. Would the project physically divide an established community? (Less-Than-Significant Impact)

The physical division of an established community typically refers to the construction of a feature (such as an interstate highway or railroad tracks) or removal of a means of access (such as a local road or bridge) that would impair mobility within an existing community, or between a community and outlying areas. For instance, the construction of an interstate highway through an existing community may constrain travel from one side of the community to another; similarly, such construction may also impair travel to areas outside of the community.

The project site is located in a developed area of Castro Valley and is surrounded by residential uses. The proposed project would result in the construction of a new community park, including trails and walkways that connect all sides of the project site to the surrounding neighborhood. In this way, the proposed project would provide better connectivity within the established residential community.

Access to the project site would be via two existing vehicle and bike/pedestrian entrances from Sydney Way and Carlton Avenue, additional bike/pedestrian and service vehicle entrances from Carlton Avenue and Stanton Avenue, and pedestrian entrances from Jennifer Drive and the existing residential community to the northwest of the project site. The proposed project would not result in the realignment or closure of any existing roads. Therefore, the proposed project would not result in the physical division of an established community or adversely affect the continuity of land uses in the vicinity, and this impact would be less than significant.

b. Would the project cause a significant environmental impact due to a conflict with any land use plan, policy, or regulation adopted for the purpose of avoiding or mitigating an environmental effect? (Less-Than-Significant Impact)

The project site is located within an urban area in unincorporated Alameda County. The project site consists of an approximately 24-acre property, which is currently undeveloped. The site is located south of Lake Chabot Regional Park and is bound by residential uses and Sydney Way to the north, residential uses and Carlton Avenue to the east, residential uses and Stanton Avenue to the west, and residential uses and Jennifer Drive to the south.

The project site is located within the Castro Valley area of unincorporated Alameda County and is subject to the land use and zoning designations of the Castro Valley Area General Plan (2012) and

the Alameda County Zoning Ordinance (Title 17, Zoning, of the Alameda County Municipal Code [1966, as amended July 19, 2022]).

Following is an evaluation of the proposed project's consistency with the applicable goals and policies of the General Plan and Zoning Ordinance. In reviewing this section, it is important to understand that the determination of whether a project is consistent with a specific policy can be subjective, and that consistency determinations are best made with a broad understanding of the often-competing policy objectives in a planning document. As a result, policy consistency determinations are ultimately made by the local decision-making body. As previously discussed, HARD is the lead agency for environmental review. The Castro Valley Municipal Advisory Council and the Alameda County Board of Supervisors would determine the proposed project's consistency with the County's applicable plans and policies, as part of the Conditional Use Permit approval. The analysis in this section is intended to provide decision-makers with a list of the goals and policies that are pertinent to the proposed project and the project site, and a recommendation regarding whether or not the proposed project would directly conflict with relevant planning directives. These recommendations are intended to supplement decision-makers' own understanding of the various policy considerations. A conflict with an applicable policy is not itself a significant impact unless it results in a significant environmental impact, as described below.

Per CEQA Guidelines, policy conflicts do not, in and of themselves, constitute significant environmental impacts. Policy conflicts are considered to be environmental impacts only when they would result in direct physical impacts or where those conflicts relate to avoiding or mitigating environmental impacts. As such, associated physical environmental impacts are discussed in this Initial Study/Mitigated Negative Declaration (IS/MND) under specific topical sections.

General Plan. The Castro Valley Area General Plan designates the site as Open Space-Park (OS-P) and Hillside Residential (RH). The OS-P land use designation provides for current and expected future locations for public parks of all sizes and types in the community. Parks may include a wide range of uses including active playing fields, recreational facilities including buildings, picnic areas, plazas, bicycle and walking trails, water features, passive green spaces, and landscaped areas. The RH land use designation is used in areas of steep slopes and/or high fire hazard areas to ensure that adequate mitigation are identified for the development of single-family detached dwellings. Lots range from 5,000 to 10,000 square feet resulting in residential densities between 4 and 8 units per net acre.

The proposed project would be consistent with the following applicable General Plan goals and policies as discussed below.

Goal 4.3-1. Provide for a variety of housing types that will meet anticipated needs while preserving and enhancing the livability and character of Castro Valley's neighborhoods.

Policy 4.3-3. Neighborhood Facilities and Infrastructure. Ensure that adequate public facilities, including parks and open space, and infrastructure improvements are provided to support new residential development.

Goal 5.1-1. Protect and enhance the hillsides, canyons, and creeks that are the foundation of Castro Valley's natural setting and visual character as well as the views of these resources from public streets, parks, trails, and other community facilities.

Goal 5.5-1. Create and enhance community gathering places in order to foster Castro Valley's identity and civic partnership.

Policy 5.5-1. Create Community Gathering Places. Establish a variety of community gathering places in Castro Valley by expanding or improving existing facilities and by creating new outdoor and indoor public spaces.

Goal 6.5-1. Expand and improve local bikeway connections and provide a safe environment for bicycle travel throughout the community.

Policy 6.5-1. Comprehensive Bikeway System. Provide a comprehensive bikeway system that is coordinated with existing and planned major destinations, community activity centers, transit stations, and schools in Castro Valley and adjoining communities.

Goal 6.6-1. Provide a safe and attractive walking environment assessable for all users, particularly disabled users, seniors, transit users, and children.

Policy 6.6-6. New Development to Incorporate Pedestrian Facilities. Design new development and redevelopment projects to facilitate pedestrian access and address any impacts to the pedestrian safety, access, and circulation.

Goal 7.1-1. Protect Castro Valley's native wildlife through conservation and restoration of natural habitat.

Policy 7.1-1. Major Wildlife Corridors Protection. Protect the major wildlife corridors that run through or are adjacent to Castro Valley: (1) the corridor along the East Bay Hills in the forest and chaparral between major interstate highways; and (2) along creeks.

Policy 7.1-2. Comprehensive Habitat Protection. preserve a continuous band of open space consisting of a variety of plant communities and wildlife habitat to provide comprehensive rather than piecemeal habitat conservation.

Policy 7.1-3. Open Space Preservation. Preserve the undeveloped areas designated as open space within planned unit developments as permanent open space.

Policy 7.1-5. Riparian Habitat. New development shall not disturb any riparian habitat.

Goal 7.3-1. Maintain, preserve, and enhance trees and vegetation to provide environmental and aesthetic benefits.

Policy 7.3-2. Native Environment. Maintain and enhance the existing environment by preserving existing native tree and plants whenever feasible, replacing trees on-site, and adding trees and other =vegetation in the public right-of-way.

Goal 8.1-1. Provide and maintain adequate sites and facilities to meet education, cultural, recreation, health care, and related needs of all present and future Castro Valley residents. Make optimal use of facilities while minimizing disruption to neighborhoods resulting from the expansion and use of the public facilities.

Policy 8.1-1. Environmental Justice in Provision of Community Facilities/Services. Ensure environmental justice in the provision of community services and facilities so that all segments of the community have equal access to facilities, and none are disproportionately affected by any potential adverse impact.

Policy 8.1-3. Design and Location of Programs and Facilities. Design and locate programs and facilities in a manner that will maximize access while avoiding over-concentration that may result in adverse impacts such as traffic and noise.

Policy 8.1-5. Park Accessibility by Non-Auto Means. Design and locate all community and neighborhood service facilities to allow for access by foot, bicycle, public transit, and other alternatives to the private automobile. When appropriate, locate facilities close to retail commercial uses or in mixed use developments to allow patrons to minimize vehicle trips.

Policy 8.1-6. Compatibility with Context. Locate and design community facilities and sites in single-family residential areas to be compatible with surrounding development and to minimize traffic, noise, and other disturbances to nearby residents by adhering to the following principles:

- Locate parking areas to divert use-related automobile traffic away from residential streets.
- Locate community and neighborhood service facilities involving high levels of activity – day and/or night –outside of, or at the perimeter of, residential neighborhoods. Where this is not possible, provide adequate buffering (e.g., use of walls, landscaping, setbacks), design measures (e.g. location of activity areas, parking areas), and regulate activities to minimize impacts on adjoining residential areas.

Policy 8.1-7. Public Ownership of Public Facilities. Where feasible retain all publicly-owned public service facilities in public ownership and maintain their use for the public benefit.

Goal 8.2-1. Provide and maintain, in coordination with other public agencies, a system of local public park and recreation facilities offering a variety of active, passive, and cultural recreational opportunities that is adequate to meet the diverse recreational needs of community residents and visitors. Also consider the additional demands of those who work in the community but are not residents.

Policy 8.2-1. Parkland Standards. Provide additional neighborhood park and recreation facilities in the Castro Valley planning area to increase and maintain a parkland standard of at least two (2) acres of neighborhood parkland and a total of at least five (5) acres of neighborhood and community park facilities for every 1,000 residents.

Policy 8.2-2. Use of HARD, EBRPD and School Districts for Neighborhood/Community Parks. Continue to rely on the Hayward Area Recreation and Park District (HARD), the East Bay Regional Park District and other public agencies such as the school districts to develop and maintain neighborhood.

Policy 8.2-6. Improvement of Existing Parks. Work with HARD and EBRPD to improve existing parks in Castro Valley. Renovate and add new facilities such as playgrounds, parking, restrooms, etc. Acquire key parcels adjacent to existing parks that would provide greater street frontage and visibility and/or make them safer and more usable.

Policy 8.2-7. Terrain of Local Parks. Ensure that the terrain of local park sites is suitable to accommodate the intended uses and activities, and doesn't present drainage problems, potential for landslides or other physical hazards or constraints.

Policy 8.2-8. Park Accessibility. Locate and plan park and recreation facilities to facilitate access by foot, bicycle, and public transit as well as private automobile.

Policy 8.2-9. Locate Neighborhood and Community Parks Near Center of Service Area. To the extent possible, locate neighborhood and community recreation facilities near the center of their service areas, except where alternative sites may offer considerable advantages (e.g., significant natural features and vistas, incorporation of a public utility easement, etc.) over a centrally located site. Neighborhood and community recreation facilities should be conveniently accessible from all parts of their service areas and not separated from residents in their service areas by natural or manmade barriers. Sites that would require hazardous travel should generally not be used as recreation facilities.

Policy 8.2-10. Locate Neighborhood and Community Parks Near Residential Areas. Neighborhood and community parks and recreation facilities should, to the extent possible, be located in or immediately adjacent to predominantly residential areas and within a reasonable 10-to-15-minute walking distance of the population the park is intended to serve.

Policy 8.2-13. Diversification and Specialization of Community Parks. Where possible, plan community parks to include natural areas; special use recreation areas and facilities, such as skate parks, bocci ball courts, or similar configurations; and community cultural resources to satisfy more diverse and specialized recreational needs and to preserve significant natural features and cultural resources.

Policy 8.2-14. Consideration of Park Accessibility, Use and Character over Size. Park accessibility, use, and character shall be considered more important than size when considering the acquisition and development of new parks and recreation facilities.

Goal 8.3-1. Provide a comprehensive system of hiking, equestrian and bicycle trails to connect major park and recreation areas within and adjacent to the Castro Valley Planning Area, to connect neighborhoods, and to provide an alternative means of access between neighborhoods and the downtown.

Policy 8.3-1. Integration of Trails in New Development. Incorporate trails, greenways, and linear recreation facilities as integral components of new development.

Policy 8.3-2. Enhancement of Public Awareness about Trails. Increase public awareness of trails and pathways.

The proposed project would involve the development of a new community park within an existing residential neighborhood. The proposed project would develop an existing, undeveloped 24-acre hilltop site with a mix of recreational and open space facilities that would serve community needs and provide opportunities for increased physical activity, social interaction, and preservation and enhancement of Castro Valley's natural setting within a currently underserved neighborhood. The project site is designated as Open Space-Park (OS-P) and Hillside Residential (RH) in the Castro Valley Area General Plan. As discussed below, the R1 zoning district within the HR land use designation allows for conditional use of the site as a community facility and gathering place. The proposed project would allow for better public use of the site as a park and community gathering place, and as such, would be consistent with the applicable land use designations. In addition, the primary goal of the landscaping plan is to maintain the site's open space character and its functionality as habitat. The proposed project would include installation of new, native landscaping and vegetation to enhance the site's ecological value while also supporting slope stabilization and stormwater management, providing shade, offering visual interest, and screening neighboring homes. In addition, the majority of the project site would be preserved as open space, allowing the site to be used as a wildlife corridor for urban-adapted species, such as deer, coyotes, and birds. The proposed park would be compatible with the mix and intensity of uses located within the vicinity of the site, which generally consist of residential and public uses, and would include improved bicycle and pedestrian access within the site that provides connections to the surrounding neighborhood. As such, the proposed project would be consistent with the applicable goals and policies of the Castro Valley Area General Plan.

Zoning Ordinance. The project site contains three zoning designations: R1-CSU-RV, OSP-CSU-RV, and PD-CSU-RV. The R1 zoning district provides for single-family residential uses. Conditional uses allowed within the R1 zoning district include community facilities, community clubhouses, parking lots, plant nurseries or greenhouses used for the cultivation and wholesale of plant materials, medical or residential care facilities, licensed transitional or supportive housing, mobile home parks, collection boxes, and soil importing. The OSP Zone provides for current and expected future locations for public parks of all sizes and types within the community. These include a wide range of uses including active playing fields, recreation facilities including buildings picnic areas plazas, bicycle and walking trails, water features, passive green spaces, and landscaped areas. The PD districts are established to encourage the arrangement of a compatible variety of uses on suitable lands in such a manner that the resulting development will be consistent with the General Plan, provide efficient use of land, encourage the use of common open areas for neighborhoods/ community use, be compatible with adjacent uses, and create an attractive, efficient, and safe environment.

As described above, the proposed project would result in the construction of a community park which is permitted under the County's zoning ordinance with a Conditional Use Permit. Further, the proposed project would contribute to implementing the Castro Valley Area General Plan goals and policies related to the provision of parks and recreation facilities.

Additional relevant policies relate to the protection of natural resources, water quality, cultural resources, visual resources, air quality, public safety from natural and human-caused hazards, provision of public services, noise and traffic. Many of the project impacts related to these topics are less than significant or are limited to the short-term construction phase of the project as described in the relevant sections of this document. With implementation of the mitigation measures contained in this document, the proposed project is consistent with all the relevant regulations and policies contained in these documents. This impact would be less than significant.

4.11 MINERAL RESOURCES

	Potentially Significant Impact	Less Than Significant with Mitigation Incorporated	Less Than Significant Impact	No Impact
Would the project:				
a. Result in the loss of availability of a known mineral resource that would be of value to the region and the residents of the state?	<input type="checkbox"/>	<input type="checkbox"/>	<input type="checkbox"/>	<input checked="" type="checkbox"/>
b. Result in the loss of availability of a locally-important mineral resource recovery site delineated on a local general plan, specific plan or other land use plan?	<input type="checkbox"/>	<input type="checkbox"/>	<input type="checkbox"/>	<input checked="" type="checkbox"/>

- a. *Would the project result in the loss of availability of a known mineral resource that would be of value to the region and the residents of the state? (No Impact)*

Minerals are any naturally occurring chemical element or compound, or groups of elements and compounds, formed from inorganic processes and organic substances including, but not limited to, coal, peat and oil bearing rock, but excluding geothermal resources, natural gas and petroleum. Rock, sand, gravel and earth are also considered minerals by the Department of Conservation when extracted by surface mining operations. The project site is located in a developed, urbanized area of Castro Valley and is not within a designated mineral resource zone as defined by the California Surface Mining and Reclamation Act of 1975. Additionally, according to the California Department of Conservation’s Division of Mine Reclamation, there are no active mines in Castro Valley. The nearest mines in Alameda County occur in the City of Pleasanton and include the Radum, Eliot, and Calmat/Pleasanton open sand and gravel pits located approximately 13 miles east of the project site.⁵⁴ As such, the project would not result in the loss of availability of a known mineral resource that would be of value to the region and residents of the state. No impact would occur.

- b. *Would the project result in the loss of availability of a locally-important mineral resource recovery site delineated on a local general plan, specific plan or other land use plan? (No Impact)*

Refer to Section 4.12.1a. The proposed project would have no impact on mineral resource recovery sites.

⁵⁴ California Department of Conservation, Division of Mine Reclamation, *Mines Online Mapper*. (Accessed January 6, 2023)

4.12 NOISE

	Potentially Significant Impact	Less Than Significant with Mitigation Incorporated	Less Than Significant Impact	No Impact
Would the project result in:				
a. Generation of a substantial temporary or permanent increase in ambient noise levels in the vicinity of the project in excess of standards established in the local general plan or noise ordinance, or applicable standards of other agencies?	<input type="checkbox"/>	<input type="checkbox"/>	<input checked="" type="checkbox"/>	<input type="checkbox"/>
b. Generation of excessive groundborne vibration or groundborne noise levels?	<input type="checkbox"/>	<input checked="" type="checkbox"/>	<input type="checkbox"/>	<input type="checkbox"/>
c. For a project located within the vicinity of a private airstrip or an airport land use plan or, where such a plan has not been adopted, within 2 miles of a public airport or public use airport, would the project expose people residing or working in the project area to excessive noise levels?	<input type="checkbox"/>	<input type="checkbox"/>	<input checked="" type="checkbox"/>	<input type="checkbox"/>

Noise is usually defined as unwanted sound. Noise consists of any sound that may produce physiological or psychological damage and/or interfere with communication, work, rest, recreation, or sleep. Several noise measurement scales exist that are used to describe noise in a particular location. A decibel (dB) is a unit of measurement that indicates the relative intensity of a sound. Sound levels in dB are calculated on a logarithmic basis. An increase of 10 dB represents a 10-fold increase in acoustic energy, while 20 dB is 100 times more intense, and 30 dB is 1,000 times more intense. Each 10 dB increase in sound level is perceived as approximately a doubling of loudness; and similarly, each 10 dB decrease in sound level is perceived as half as loud. Sound intensity is normally measured through the A-weighted sound level (dBA), and this scale gives greater weight to the frequencies of sound to which the human ear is most sensitive. The A-weighted sound level is the basis for 24-hour sound measurements which better represent how humans are more sensitive to sound at night.

As noise spreads from a source, it loses energy so that the farther away the noise receiver is from the noise source, the lower the perceived noise level would be. Geometric spreading causes the sound level to attenuate or be reduced, resulting in a 6 dB reduction in the noise level for each doubling of distance from a single point source of noise to the noise sensitive receptor of concern.

There are many ways to rate noise for various time periods, but an appropriate rating of ambient noise affecting humans also accounts for the annoying effects of sound. Equivalent continuous sound level (L_{eq}) is the total sound energy of time varying noise over a sample period. However, the predominant rating scales for human communities in the State of California are the L_{eq} , the community noise equivalent level (CNEL), and the day-night average level (L_{dn}) based on A-weighted decibels (dBA). CNEL is the time varying noise over a 24-hour period, with a 5 dBA weighting factor applied to the hourly L_{eq} for noises occurring from 7:00 p.m. to 10:00 p.m. (defined as relaxation hours) and 10 dBA weighting factor applied to noise occurring from 10:00 p.m. to 7:00 a.m. (defined as sleeping hours). L_{dn} is similar to the CNEL scale, but without the adjustment for events occurring during the evening relaxation hours. CNEL and L_{dn} are within one dBA of each other and are normally

exchangeable. The noise adjustments are added to the noise events occurring during the more sensitive hours.

A project would result in a significant noise effect if it would substantially increase the ambient noise levels for adjoining areas or conflict with adopted environmental plans and goals of applicable regulatory agencies, including, as appropriate, the County of Alameda.

Certain land uses are considered more sensitive to noise than others. Examples of these include residential areas, educational facilities, hospitals, childcare facilities, and senior housing. The project site is generally surrounded by residential uses. The closest sensitive receptors are the residences located to the east, approximately within 10 feet from the project site boundary and approximately 370 feet from the center of project site.

Existing noise sources at the project site are primarily associated with traffic on surrounding roadways, including Sydney Way, Carlton Avenue, Stanton Avenue, and Jennifer Drive.

The County of Alameda sets noise and land use compatibility standards in the General Plan. The Countywide Noise Element does not explicitly state what the acceptable outdoor noise level is for recreational parks, but it references noise and land use compatibility standards developed by the Association of Bay Area Governments (ABAG), which identified a CNEL of 65 dBA or less as a basis for finding little noise impact on residential land uses, 65 to 70 dBA as a moderate impact, and any level above 70 dBA as a significant impact, which is used for this assessment.

In addition, Alameda County regulates noise in the County’s Noise Ordinance. Table 4.G shows the number of cumulative minutes that a particular external noise level is permitted for receiving sensitive land uses such as single- or multi- family residential, school, hospital, church or public library properties. The County Noise Ordinance also restricts the operation and use of electric and gas-powered tools in residential areas and authorizes the imposition of more stringent noise limits on activities subject to a conditional use permit. The Noise Ordinance does not apply to noise associated with construction if such activities take place between 7:00 a.m. and 7:00 p.m. on weekdays or between 9:00 a.m. and 8:00 p.m. on weekends.

Table 4.G: Exterior Noise Level Standards – Sensitive Land Uses

Category	Cumulative Number of Minutes in any one-hour time period	Daytime 7 a.m. to 10 p.m.	Nighttime 10 p.m. to 7 a.m.
1	30	50	45
2	15	55	50
3	5	60	55
4	1	65	60
5	0	70	65

Source: Section 6.60.040 of the County of Alameda Code of Ordinance.

¹ Daytime means 7:00 a.m. to 10:00 p.m.

² Nighttime means 10:01 p.m. to 6:59 a.m.

dBA = A-weighted decibels

L_{eq} = equivalent continuous sound level

Because the County does not have construction noise level limits, construction noise was assessed using criteria from the *Transit Noise and Vibration Impact Assessment Manual*.⁵⁵ Table 4.H shows the FTA’s Detailed Analysis Construction Noise Criteria based on the composite noise levels per construction phase.

Table 4.H: Detailed Assessment Construction Noise Criteria

Land Use	Daytime 1-hour L_{eq} (dBA)
Residential	80
Commercial	85
Industrial	90

Source: *Transit Noise and Vibration Impact Assessment Manual* (FTA 2018).

dBA = A-weighted decibels

L_{eq} = equivalent continuous sound level

Vibration standards included in the FTA Manual are used in this analysis for ground-borne vibration impacts on human annoyance. The criteria for environmental impact from ground-borne vibration and noise are based on the maximum levels for a single event. Table 4.I provides the criteria for assessing the potential for interference or annoyance from vibration levels in a building.

Table 4.I: Interpretation of Vibration Criteria for Detailed Analysis

Land Use	Max L_v (VdB) ¹	Description of Use
Workshop	90	Vibration that is distinctly felt. Appropriate for workshops and similar areas not as sensitive to vibration.
Office	84	Vibration that can be felt. Appropriate for offices and similar areas not as sensitive to vibration.
Residential Day	78	Vibration that is barely felt. Adequate for computer equipment and low-power optical microscopes (up to 20×).
Residential Night and Operating Rooms	72	Vibration is not felt, but ground-borne noise may be audible inside quiet rooms. Suitable for medium-power microscopes (100×) and other equipment of low sensitivity.

Source: *Transit Noise and Vibration Impact Assessment Manual* (FTA 2018).

¹ As measured in 1/3-Octave bands of frequency over the frequency range 8 to 80 Hertz.

FTA = Federal Transit Administration

L_v = velocity in decibels

VdB = vibration velocity decibels

Max = maximum

Table 4.J lists the potential vibration building damage criteria associated with construction activities, as suggested in the FTA Manual. FTA guidelines show that a vibration level of up to 0.5 in/sec in PPV is considered safe for buildings consisting of reinforced concrete, steel, or timber (no plaster), and would not result in any construction vibration damage. For non-engineered timber and masonry buildings, the construction building vibration damage criterion is 0.2 in/sec in PPV.

⁵⁵ Federal Transit Administration. 2018. *Transit Noise and Vibration Impact Assessment Manual FTA Report No. 0123*. September.

Table 4.J: Construction Vibration Damage Criteria

Building Category	PPV (in/sec)
Reinforced concrete, steel, or timber (no plaster)	0.50
Engineered concrete and masonry (no plaster)	0.30
Non-engineered timber and masonry buildings	0.20
Buildings extremely susceptible to vibration damage	0.12

Source: *Transit Noise and Vibration Impact Assessment Manual* (FTA 2018).
FTA = Federal Transit Administration PPV = peak particle velocity
in/sec = inch/inches per second

In *California Building Industry Association v. Bay Area Air Quality Management District*, the Supreme Court of California ruled that “CEQA generally does not require an analysis of how existing environmental conditions will affect a project’s future users or residents.”⁵⁶ With this ruling, CEQA no longer considers the impact of the environment on a project to be an environmental impact, unless the project could exacerbate an existing environmental hazard. Therefore, an environmental document is not required to include an evaluation of whether the project would have the potential to expose project site sensitive receptors to excessive noise from existing noise sources near the project site, and such an analysis is not included in the impact analysis below. However, the County of Alameda General Plan requires that a noise analysis be completed to ensure that the people associated with sensitive uses (i.e. residences, motels and hotels, schools, libraries, churches, hospitals, nursing homes, auditoriums, natural areas, parks and outdoor recreation areas) are not exposed to noise levels in excess of General Plan standards. To address this requirement, an analysis of noise levels that would be experienced in the exterior living areas as well as inside the proposed residences was conducted. That analysis is presented below.

Exterior Noise Assessment. The existing measured noise levels at the project site range from approximately 56.9 dBA CNEL to 58.3 dBA CNEL, based on existing noise levels measured between February 15, 2023, and February 16, 2023, in the vicinity of the project (Figure 8). As compared to the information in the County’s Noise Element section of this report, an exterior noise level of up to 65 dBA CNEL would be considered the standard for community noise exposure. With estimated noise levels approaching 59 dBA CNEL, the noise levels are below the County’s 65 dBA CNEL exterior noise level standard. Therefore, noise reduction measures would not be required.



⁵⁶ Cal. Building Industry Assn. v. Bay Area Air Quality Mgmt. Dist. (2015) 62 Cal.4th 369, 386.

This page intentionally left blank



FIGURE 8

LSA

- LEGEND
-  Project Site Boundary
 -  LF-1 Long-term Noise Monitoring Location

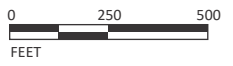

SOURCE: Google Earth 2023

I:\WRT2102\G\Noise_Locs.ai (3/28/2023)

Valley View Park Project
Noise Monitoring Locations

This page intentionally left blank

- a. *Would the project result in generation of a substantial temporary or permanent increase in ambient noise levels in the vicinity of the project in excess of standards established in the local general plan or noise ordinance, or applicable standards of other agencies? (Less-Than-Significant Impact)*

Construction-Period Impacts. Construction of the proposed project could include construction activities that would result in a temporary increase in ambient noise levels in the project site vicinity. Maximum construction noise levels would be short-term, generally intermittent depending on the construction phase, and variable depending on receiver distance from the active construction zone. The duration of noise impacts generally would be from one day to several days depending on the phase of construction. Project construction would occur for approximately 1 year. The level and types of noise impacts that would occur during construction are described below.

Short-term noise impacts would occur during site preparation and grading activities. Table 4.K lists maximum noise levels recommended for noise impact assessments for typical construction equipment, based on a distance of 50 feet between the equipment and a noise receptor. Construction-related short-term noise levels would be higher than existing ambient noise levels currently in the project area but would no longer occur once construction of the project is completed.

Two types of short-term noise impacts could occur during construction of the proposed project. The first type involves construction crew commutes and the transport of construction equipment and materials to the site for the proposed project, which would incrementally increase noise levels on roads leading to the site. As shown in Table 4.K, there would be a relatively high single-event noise exposure potential at a maximum level of 85 dBA L_{max} with trucks passing from 50 feet.

The second type of short-term noise impact is related to noise generated during excavation, grading, and construction on the project site. Construction is performed in discrete steps, or phases, each with its own mix of equipment and, consequently, its own noise characteristics. These various sequential phases would change the character of the noise generated on site. Therefore, the noise levels vary as construction progresses. Despite the variety in the type and size of construction equipment, similarities in the dominant noise sources and patterns of operation allow construction-related noise ranges to be categorized by work phase.

Average maximum noise levels range up to 90 dBA L_{max} at 50 feet during the noisiest construction phases. The site preparation and grading phases, including excavation of the site, tend to generate the highest noise levels because earthmoving machinery is the noisiest construction equipment. Earthmoving equipment includes excavating machinery such as backfillers, bulldozers, draglines, and front loaders. Earthmoving and compacting equipment includes compactors, scrapers, and graders. Typical operating cycles for these types of construction equipment may involve 1 or 2 minutes of full-power operation followed by 3 or 4 minutes at lower power settings.

As identified above, the project site is generally surrounded by residential uses. The closest receptors include the residences located east, west, and south of the project site approximately 370 feet from the center of project site and residential uses located approximately 550 feet north of the project. The 370-foot distance would decrease the noise level by approximately 18 dBA compared to

the noise level measured at 50 feet from the construction activity. Therefore, the closest off-site receptors may be subject to short-term construction noise levels of 70 dBA L_{eq} when construction is occurring at the center of project site, and this noise level would be lower than the 80 dBA L_{eq} criteria established by FTA for residential uses.

Table 4.K: Typical Construction Equipment Noise Levels

Equipment Description	Acoustical Usage Factor (%)	Maximum Noise Level (L_{max}) at 50 Feet ¹
Backhoes	40	80
Compactor (ground)	20	80
Compressor	40	80
Cranes	16	85
Dozers	40	85
Dump Trucks	40	84
Excavators	40	85
Flat Bed Trucks	40	84
Forklift	20	85
Front-end Loaders	40	80
Graders	40	85
Impact Pile Drivers	20	95
Jackhammers	20	85
Pick-up Truck	40	55
Pneumatic Tools	50	85
Pumps	50	77
Rock Drills	20	85
Rollers	20	85
Scrapers	40	85
Tractors	40	84
Welder	40	73

Source: Roadway Construction Noise Model (FHWA 2006).

Note: Noise levels reported in this table are rounded to the nearest whole number.

¹ Maximum noise levels were developed based on Spec 721.560 from the Central Artery/Tunnel (CA/T) program to be consistent with the City of Boston’s Noise Code for the “Big Dig” project.

L_{max} = maximum instantaneous sound level

As stated above, construction activities are regulated by the County’s Noise Ordinance. The proposed project would comply with the construction hours specified in the County’s Noise Ordinance, which states that construction activities are allowed between the hours of 7:00 a.m. and 7:00 p.m. on weekdays or between 9:00 a.m. and 8:00 p.m. on weekends.

Long-Term Noise Impacts. The project would generate long-term noise impacts from traffic and park operations as discussed below.

Traffic Noise Impacts. Based on the results of the traffic analysis conducted for this Initial Study, it was determined that a net additional 262 average daily trips (ADT) would be generated by the proposed project. The existing traffic volume on the adjacent segment of Sydney Way between Stanton Avenue and Carlton Avenue is 1,320 based on traffic counts. The following equation was used to determine the potential impacts of the project:

$$\text{Change in CNEL} = 10 \log_{10} [V_{e+p} / V_{\text{existing}}]$$

where: V_{existing} = existing daily volumes
 V_{e+p} = existing daily volumes plus project
Change in CNEL = increase in noise level due to the project

The results of the calculations show that an increase of approximately 0.8 dBA CNEL is expected along the streets adjacent to the project site. A noise level increase of less than 1 dBA would not be perceptible to the human ear; therefore, the traffic noise increases in the vicinity of the project site resulting from the proposed project would be less than significant.

Park Operations Noise Impacts. The proposed project does not contain uses which are expected to utilize amplified speech or music and would not host sporting events. The proposed uses are expected to be similar to those with a standard community park and any instances in which noise levels generate a disturbance, the County's Municipal Code would be utilized to minimize the operational impacts which are classified as nuisance issues. Therefore, noise increases in the vicinity of the project site resulting from the proposed project would be less than significant.

b. Would the project result in generation of excessive groundborne vibration or groundborne noise levels? (Less-Than-Significant with Mitigation Incorporated)

Vibration refers to groundborne noise and perceptible motion. Groundborne vibration is almost exclusively a concern inside buildings and is rarely perceived as a problem outdoors. Vibration energy propagates from a source, through intervening soil and rock layers, to the foundations of nearby buildings. The vibration then propagates from the foundation throughout the remainder of the structure. Building vibration may be perceived by the occupants as the motion of building surfaces, rattling of items on shelves or hanging on walls, or as a low-frequency rumbling noise. The rumbling noise is caused by the vibrating walls, floors, and ceilings radiating sound waves. Annoyance from vibration often occurs when the vibration exceeds the threshold of perception by 10 dB or less. This is an order of magnitude below the damage threshold for normal buildings.

Typical sources of groundborne vibration are construction activities (e.g., pavement breaking and operating heavy-duty earthmoving equipment), rail activity, and occasional traffic on rough roads. In general, groundborne vibration from standard construction practices is only a potential issue when within 25 feet of sensitive uses. Groundborne vibration levels from construction activities very rarely reach levels that can damage structures; however, these levels are perceptible near the active construction site. With the exception of older buildings built prior to the 1950s or buildings of historic significance, potential structural damage from heavy construction activities rarely occurs. When roadways are smooth, vibration from traffic (even heavy trucks) is rarely perceptible.

The roadways surrounding the project area, including Sydney Way, Carlton Avenue, Stanton Avenue, Jennifer Drive, and the existing driveways, are paved, smooth, and unlikely to cause significant groundborne vibration. In addition, the rubber tires and suspension systems of buses and other on-road vehicles make it unusual for on-road vehicles to cause groundborne noise or vibration problems. It is, therefore, assumed that no such vehicular vibration impacts would occur and no vibration impact analysis of on-road vehicles is necessary.

The following vibration impact analysis discusses the level of human annoyance using vibration levels in VdB and assesses the potential for structural damages using vibration levels in PPV (in/sec) because vibration levels calculated in RMS are best for characterizing human response to building vibration, while vibration level in PPV is best used to characterize potential for damage.

Construction Vibration. Construction of the proposed project could result in the generation of groundborne vibration. This construction vibration impact analysis discusses the level of human annoyance using vibration levels in VdB and assesses the potential for building damages using vibration levels in PPV (in/sec) because vibration levels calculated in RMS are best for characterizing human response to building vibration, while vibration level in PPV is best used to characterize potential for damage. The FTA Transit Noise and Vibration Impact Assessment guidelines indicate that a vibration level up to 102 VdB (an equivalent to 0.5 in/sec in PPV) is considered safe for buildings consisting of reinforced concrete, steel, or timber (no plaster), and would not result in any construction vibration damage. For a non-engineered timber and masonry building, the construction vibration damage criterion is 94 VdB (0.2 in/sec in PPV).

Table 4.L shows the PPV and VdB values at 25 feet from a construction vibration source. As shown in Table 4.L, bulldozers and other heavy-tracked construction equipment (except for pile drivers and vibratory rollers) generate approximately 87 VdB of groundborne vibration when measured at 25 feet, based on the Transit Noise and Vibration Impact Assessment. At this level, groundborne vibration would result in potential annoyance to residents and workers, but would not cause any damage to the buildings. Construction vibration, similar to vibration from other sources, would not have any significant effects on outdoor activities (e.g., those outside of residences and commercial/office buildings in the project vicinity). Outdoor site preparation for the proposed project is expected to include the use of bulldozers and loaded trucks. The greatest levels of vibration are anticipated to occur during the grading phase. All other phases are expected to result in lower vibration levels.

Table 4.L: Vibration Source Amplitudes for Construction Equipment

Equipment	Reference PPV/L _v at 25 feet	
	PPV (in/sec)	L _v (VdB) ^a
Pile Driver (Impact), Typical	0.644	104
Pile Driver (Sonic), Typical	0.170	93
Vibratory Roller	0.210	94
Hoe Ram	0.089	87
Large Bulldozer	0.089	87
Caisson Drilling	0.089	87
Loaded Trucks	0.076	86
Jackhammer	0.035	79
Small Bulldozer	0.003	58

Sources: *Transit Noise and Vibration Impact Assessment* (FTA 2018).

^a RMS vibration velocity in decibels (VdB) is 1 μin/sec.

μin/sec = micro-inches per second

FTA = Federal Transit Administration

in/sec = inches per second

L_v = velocity in decibels

PPV = peak particle velocity

RMS = root-mean-square

VdB = vibration velocity decibels

The distance to the nearest buildings for vibration impact analysis is measured between the nearest off-site buildings and the project boundary (assuming the construction equipment would be used at or near the project boundary) because vibration impacts occur normally within the buildings. The formula for vibration transmission is provided below.

$$L_v\text{dB} (D) = L_v\text{dB} (25 \text{ ft}) - 30 \text{ Log} (D/25)$$

$$PPV_{\text{equip}} = PPV_{\text{ref}} \times (25/D)^{1.5}$$

For typical construction activity, the equipment with the highest vibration generation potential is the large bulldozer, which would generate 87 VdB at 25 feet. The closest surrounding buildings to the project site include the existing single-family residences, located approximately within 10 feet of the project site boundary. The residential buildings would be subject to vibration levels of up to 99 VdB (0.352 PPV [in/sec]). This vibration level at the nearest building from construction equipment would exceed the FTA threshold of 94 VdB (0.2 in/sec PPV) for building damage. Vibration levels at all other buildings would be lower. Although construction vibration levels at the nearest buildings would have the potential to result in annoyance, these vibration levels would no longer occur once construction of the project is completed. Therefore, construction would not result in any vibration damage, and impacts would be less than significant with the incorporation of Mitigation Measure NOI-1 as detailed below.

Mitigation Measure NOI-1: Due to the close proximity to surrounding structures, the County of Alameda (County) Director of Community Development, or designee, shall verify prior to issuance of demolition or grading permits, that the approved plans require that the construction contractor shall implement the following mitigation measures during project construction activities to ensure that damage does

not occur at surrounding structures should heavy equipment be necessary within 15 feet of surrounding structures:

- Identify structures that are located within 15 feet (ft) of heavy construction activities and that have the potential to be affected by ground-borne vibration. This task shall be conducted by a qualified structural engineer as approved by the County's Director of Community Development, or designee.
- Develop a vibration monitoring and construction contingency plan for approval by the County Director of Community Development, or designee, to identify structures where monitoring would be conducted; set up a vibration monitoring schedule; define structure-specific vibration limits; and address the need to conduct photo, elevation, and crack surveys to document before and after construction conditions. Construction contingencies would be identified for when vibration levels approached the limits.
- At a minimum, monitor vibration during initial site preparation activities. Monitoring results may indicate the need for more or less intensive measurements.
- When vibration levels approach limits, suspend construction and implement contingencies as identified in the approved vibration monitoring and construction contingency plan to either lower vibration levels or secure the affected structures.

Implementation of Mitigation Measure NOI-1 would reduce the level of the potential impact through the development and implementation of a vibration monitoring and construction contingency plan; monitoring of vibration during site preparation activities; and suspension of construction and implementation of contingencies, if needed. This process would to ensure that damage does not occur at surrounding structures should heavy equipment be necessary within 15 feet of surrounding structures. Therefore, with implementation of Mitigation Measure NOI-1, this impact would be less than significant with mitigation incorporated.

c. For a project located within the vicinity of a private airstrip or an airport land use plan or, where such a plan has not been adopted, within 2 miles of a public airport or public use airport, would the project expose people residing or working in the project area to excessive noise levels? (Less-Than-Significant Impact)

The closest airport to the project site is the Hayward Executive Airport, located approximately 3.5 miles southwest of the project site. In addition, the Oakland International Airport is located approximately 6 miles northwest of the project site. The project site is not located within the 55 dBA CNEL noise contours for either of these airports and is not located within the vicinity of a private airstrip. Although aircraft-related noise may be audible on the project site, the proposed project

would not expose people residing or working in the project area to excessive noise levels due to the proximity of a public airport. This impact would be less than significant.

4.13 POPULATION AND HOUSING

	Potentially Significant Impact	Less Than Significant with Mitigation Incorporated	Less Than Significant Impact	No Impact
Would the project:				
a. Induce substantial unplanned population growth in an area, either directly (for example, by proposing new homes and businesses) or indirectly (for example, through extension of roads or other infrastructure)?	<input type="checkbox"/>	<input type="checkbox"/>	<input type="checkbox"/>	<input checked="" type="checkbox"/>
b. Displace substantial numbers of existing people or housing, necessitating the construction of replacement housing elsewhere?	<input type="checkbox"/>	<input type="checkbox"/>	<input type="checkbox"/>	<input checked="" type="checkbox"/>

a. Would the project induce substantial unplanned population growth in an area, either directly (for example, by proposing new homes and businesses) or indirectly (for example, through extension of roads or other infrastructure)? (No Impact)

The proposed project would improve the project site as a community park. Lake Chabot Regional Park to the north of the project site provides a recreational resource to Castro Valley, however the community itself has limited park land or recreational amenities. The proposed project would serve an important need for the surrounding neighborhood and for Castro Valley. No new housing, commercial or industrial space would be developed as part of the proposed project. The proposed project would not result in the conversion of adjacent land uses or provide access to previously inaccessible areas. It would not provide additional major infrastructure or increase the capacity of the existing water system.

Maintenance and operation of the park would be conducted by existing HARD staff or their hired maintenance contractors. No new employees would be generated by the proposed project. As such, the project would not induce substantial unplanned population growth in the area, either directly or indirectly. This impact would be less than significant.

b. Would the project displace substantial numbers of existing people or housing, necessitating the construction of replacement housing elsewhere? (No Impact)

The project site is currently undeveloped, and no permanent housing is located on the project site. As such, development of the proposed project would not remove existing housing, necessitating the construction of replacement housing elsewhere. Therefore, no impact would occur.

4.14 PUBLIC SERVICES

	Potentially Significant Impact	Less Than Significant with Mitigation Incorporated	Less Than Significant Impact	No Impact
Would the project:				
a. Result in substantial adverse physical impacts associated with the provision of new or physically altered governmental facilities, need for new or physically altered governmental facilities, the construction of which could cause significant environmental impacts, in order to maintain acceptable service ratios, response times or other performance objectives for any of the public services:				
i. Fire protection?	<input type="checkbox"/>	<input type="checkbox"/>	<input checked="" type="checkbox"/>	<input type="checkbox"/>
ii. Police protection?	<input type="checkbox"/>	<input type="checkbox"/>	<input checked="" type="checkbox"/>	<input type="checkbox"/>
iii. Schools?	<input type="checkbox"/>	<input type="checkbox"/>	<input type="checkbox"/>	<input checked="" type="checkbox"/>
iv. Parks?	<input type="checkbox"/>	<input type="checkbox"/>	<input checked="" type="checkbox"/>	<input type="checkbox"/>
v. Other public facilities?	<input type="checkbox"/>	<input type="checkbox"/>	<input type="checkbox"/>	<input checked="" type="checkbox"/>

a. Would the project result in substantial adverse physical impacts associated with the provision of new or physically altered governmental facilities, need for new or physically altered governmental facilities, the construction of which could cause significant environmental impacts, in order to maintain acceptable service ratios, response times or other performance objectives for any of the public services:

i. Fire protection? (Less-Than-Significant Impact)

The Alameda County Fire Department (ACFD) provides fire protection and emergency services to the unincorporated areas of Alameda County (excluding Fairview), the cities of San Leandro, Dublin, Newark, Union City and Emeryville. ACFD has 29 fire stations and 35 companies serving densely populated urban areas, waterways, industrial centers, extensive urban interface, agricultural, and wildland regions. The ACFD employs over 400 personnel and 100 Reserve Firefighters.⁵⁷ The nearest fire station to the project site is Fire Station 26 located at 18770 Lake Chabot Road approximately 0.3 miles east of the project site.

Implementation of the proposed project would improve the site as a community park to serve the surrounding residential neighborhood. Use of the site may increase as a result of proposed improvements. However, visitors to the site are anticipated to be those who generally reside within walking distance of the project site or come primarily from the local neighborhood. Because proposed improvements would be for recreation and would not include housing units or other structures, the incremental increase in demand for fire protection services would not be significant and would not exceed the physical and financial capabilities of the ACFD, resulting in the need for new or expanded fire services. In addition, proposed improvements would be located within a park

⁵⁷ Alameda County Fire Department. Alameda County Fire Department. Website: <https://fire.acgov.org>. (accessed January 6, 2023)

facility, and would be clearly marked and signed to aid in access and timely response in medical emergencies. Therefore, impacts to fire protection would be less than significant.

ii. Police protection? (Less-Than-Significant Impact)

The Alameda County Sheriff's Office provides police protection to the project area and project site. The Alameda County's Extended Police Protection County Service Area (CSA), administered by the County Sheriff's Office, was established by the Alameda Local Agency Formation Commission (LAFCO) in 1991 as a dependent special district to supplement funding for police services in the unincorporated area. The CSA serves an area of 428.3 square miles with a population of 183,149, about a third of who live in Castro Valley. The County Sheriff provides emergency dispatch services, receives 911 calls, and dispatches patrols from the Eden Township Substation located at 150th Avenue in San Leandro. The Office's Records and Crime Analysis divisions and the Emergencies Services Dispatch Center are located in a separate building. The California Highway Patrol is responsible for enforcing the State Vehicle Code in Castro Valley, including traffic and parking, and operates a community patrol in Castro Valley.

The average response times for the Sheriff's Office for calls placed from Castro Valley are 11:48 minutes for calls requiring an immediate emergency response and 17:13 for nonemergency calls requiring an urgent response. This is substantially higher than the 4:25 median emergency response time for all Alameda County police service providers. On a per capita basis, the Department's staffing levels are lower than countywide levels, with 1.4 sworn officers per 1,000 residents compared with 1.6 per 1,000 residents for all county police service providers.⁵⁸

The Sheriff's Office proposes to consolidate its existing law enforcement facilities in a new 220,000 square foot complex to be constructed on the site of the existing Fairmont Animal Shelter on Fairmont Drive, which would allow relocation of services from the Eden Township Station as well as the Coroner's Bureau, now located in downtown Oakland.

Implementation of the proposed project would improve the site as a community park to serve the surrounding residential neighborhood. Use of the site may increase as a result of proposed improvements. However, visitors to the site are anticipated to be those who generally reside within walking distance of the project site or come primarily from the local neighborhood. Because proposed improvements would be for recreation and would not include housing units or other structures, the incremental increase in demand for police protection services would not be significant and would not exceed the already limited physical and financial capabilities of the Sheriff's Office, resulting in the need for new or expanded police protection services. In addition, provision of the proposed park would enhance the quality of life for the community, which promotes community cohesion and reduces crime. Implementation of parks and other community-oriented projects is consistent with the Community Capitals Policing approach⁵⁹ adopted by the

⁵⁸ Alameda County Community Development Agency. 2012. *Castro Valley Area General Plan*. March.

⁵⁹ Alameda County Sheriff's Office. 2019. Community Capitals Policing, A New Brand of Public Safety presentation. Available online at: www.acgov.org/board/bos_calendar/documents/DocsAgendaReg_1_10_19/GENERAL%20ADMINISTRATION/Regular%20Calendar/Community_capitals_policing_1_10_19.pdf. (Accessed January 6, 2023).

Alameda County Sheriff's Office. Therefore, impacts to police protection would be less than significant.

iii. Schools? (No Impact)

The project site is served by the Castro Valley Unified School District, which operates one preschool, nine elementary schools, two middle schools, and two high schools, one virtual academy, and two adult education and transitions schools within the Castro Valley Area of Alameda County.⁶⁰ Implementation of the proposed project would not substantially induce housing or population growth, either directly or indirectly, within Castro Valley. Therefore, the proposed project would not result in an increase in the number of school-age children in the area. As such, the proposed project would not increase demand for schools and no impact would occur.

v. Parks? (Less-Than-Significant Impact)

Implementation of the proposed project would improve the site as a community park to serve the adjacent residential development. Lake Chabot Regional Park to the north of the project site provides a recreational resource to Castro Valley, however the community itself has limited park land or recreational amenities. The proposed project would serve an existing demand for park uses for residents of Castro Valley. The proposed project would have a beneficial impact, as use at other existing neighborhood and regional parks or other recreational facilities could be reduced with provision of the proposed park improvements. Therefore, the proposed project would not result in substantial adverse physical impacts associated with new parks or the need for new parks, which could cause environmental impacts. This impact would be less than significant.

v. Other public facilities? (No Impact)

As noted above, the proposed project does not include the construction of any new residential uses and would not substantially induce housing or population growth, either directly or indirectly, within the Castro Valley Area. Therefore, the proposed project would not result in increased demand for other public facilities, such as libraries or community centers. No impact would occur.

⁶⁰ Castro Valley Unified School District. *Schools*. Castro Valley Unified School District. Website:<https://www.cv.k12.ca.us>. (accessed January 6, 2023).

4.15 RECREATION

	Potentially Significant Impact	Less Than Significant with Mitigation Incorporated	Less Than Significant Impact	No Impact
a. Would the project increase the use of existing neighborhood and regional parks or other recreational facilities such that substantial physical deterioration of the facility would occur or be accelerated?	<input type="checkbox"/>	<input type="checkbox"/>	<input checked="" type="checkbox"/>	<input type="checkbox"/>
b. Does the project include recreational facilities or require the construction or expansion of recreational facilities which might have an adverse physical effect on the environment?	<input type="checkbox"/>	<input type="checkbox"/>	<input checked="" type="checkbox"/>	<input type="checkbox"/>

a. *Would the project increase the use of existing neighborhood and regional parks or other recreational facilities such that substantial physical deterioration of the facility would occur or be accelerated? (Less-Than-Significant Impact)*

The proposed project would redevelop the project site as a community park. Implementation of the proposed project would provide public access to the project site for use as a community park, alleviating some recreation needs in the surrounding neighborhood. Lake Chabot Regional Park to the north of the project site provides a recreational resource to Castro Valley, however the community itself has limited park land or recreational amenities. The proposed project would provide a park use for the surrounding neighborhood and for Castro Valley, serving an existing demand from residents of Castro Valley. As such, the proposed project would have a beneficial impact to existing recreational facilities, as use at other existing neighborhood and regional parks or other recreational facilities may be reduced with the provision of park improvements at the project site. Therefore, this impact would be less than significant.

b. *Does the project include recreational facilities or require the construction or expansion of recreational facilities which might have an adverse physical effect on the environment? (Less-Than-Significant Impact)*

The proposed project would improve the project site for use as a community park including recreational facilities such as a multi-purpose grass area, play area, and biking/pedestrian trails. Potential adverse effects on the environment related to the development of the proposed project have been evaluated in this IS/MND. Implementation of the mitigation measures contained in this IS/MND would reduce potential impacts to less than significant.

4.16 TRANSPORTATION

	Potentially Significant Impact	Less Than Significant with Mitigation Incorporated	Less Than Significant Impact	No Impact
Would the project:				
a. Conflict with a program, plan, ordinance or policy addressing the circulation system, including transit, roadway, bicycle and pedestrian facilities?	<input type="checkbox"/>	<input type="checkbox"/>	<input checked="" type="checkbox"/>	<input type="checkbox"/>
b. Conflict or be inconsistent with CEQA Guidelines §15064.3, subdivision (b)?	<input type="checkbox"/>	<input type="checkbox"/>	<input checked="" type="checkbox"/>	<input type="checkbox"/>
c. Substantially increase hazards due to a geometric design feature (e.g., sharp curves or dangerous intersections) or incompatible uses (e.g., farm equipment)?	<input type="checkbox"/>	<input type="checkbox"/>	<input checked="" type="checkbox"/>	<input type="checkbox"/>
d. Result in inadequate emergency access?	<input type="checkbox"/>	<input type="checkbox"/>	<input checked="" type="checkbox"/>	<input type="checkbox"/>

a. Would the project conflict with a program plan, ordinance or policy addressing the circulation system, including transit, roadway, bicycle and pedestrian facilities? (Less-Than-Significant Impact)

The Alameda County Transportation Commission has established a 100 net new peak-hour trip threshold for requiring preparation of a traffic impact analysis. LSA has examined the peak trip generation potential for both the construction and operation period, as provided below.

Short-Term Construction Impact. Construction is anticipated to require approximately 12 to 24 months. Construction would require use of typical construction equipment for grading the site and installing park facilities. Construction would occur during daylight hours, from approximately 7:00 a.m. to 7:00 p.m., daily. Construction staging would occur on the project site. Construction workers, equipment and deliveries would access the site via Sydney Way, Stanton Avenue (at Perrich Avenue), and Carlton Avenue (at Severini Lane). Given the size of the project site, it is anticipated that fewer than 100 construction workers would be required on any given day, resulting in fewer than 100 peak hour trips. This is less than threshold for providing traffic impact analysis according to County guidelines.

Operational Impacts. The project would result in the construction of a 24-acre park intended to serve the surrounding neighborhood. Trip generation rates provided in the Institute of Transportation Engineers (ITE) *Trip Generation Manual*, Eleventh Edition identify vehicle trips associated with various land uses based on surveys of similar sites around the country. As shown in Table 4.M, application of the ITE trip rates for a public park would indicate that the proposed project would generate few vehicle trips during the typical AM and PM commute periods as walking trips from the surrounding neighborhood would be expected. However, in order to present a conservative analysis, LSA considered whether specific park elements that might have the potential to generate trips at a more intensive rate than the remainder of the park. In particular, the potential dog park use proposed by the project has the potential to generate more trips than identified in the ITE *Trip Generation Manual*.

The ITE *Trip Generation Manual* does not contain specific rates for dog parks, but rates surveyed at operating dog parks could be applied. Data collected by LSA appeared to show similar trip generation characteristics for dog parks regardless of the size of the fenced area within each dog park. Therefore, Table 4.M includes an average for the surveyed dog parks provides that trip generation. The total trip generation potential using this more conservative methodology is displayed in Table 4.M. As shown in the table, the trip generation during either peak commute hour is still well below the County’s threshold for providing traffic impact analysis.

Table 4.M: Trip Generation Summary

Land Use (Land Use Code)	Size	Unit	ADT	AM Peak Hour			PM Peak Hour		
				In	Out	Total	In	Out	Total
Trip Rates¹									
Park (411)		Acre	0.78	0.01	0.01	0.02	0.06	0.05	0.11
Dog Park ²		Park	243	10	5	15	15	9	24
Trip Generation									
Park	24	Acre	19	0	0	0	2	1	3
Dog Park	1	Park	243	10	5	15	15	9	24
Total			262	10	5	15	17	10	27

¹ Trip rates referenced from the ITE *Trip Generation Manual*, 11th Edition

² Trip rates based on similar surveyed sites

ADT = average daily trips

Emp = employee

ITE = Institute of Transportation Engineers

LSA contracted with an independent data collection company to collect roadway and intersection turn volume data in the vicinity of the project. These data were collected on a typical weekday, Wednesday, February 1, 2023. Traffic volume data is provided in Appendix D. Table 4.N shows the daily traffic volume currently using area roadways. The proposed project includes construction of two new parking areas to provide vehicle access from Sydney Way and Carlton Avenue. The existing entrances from Sydney Way and Carlton Avenue would be extended into the project site and would include approximately 15 to 20 shoulder parking spaces and approximately 8 to 10 ADA-accessible parking stalls. Based on the even distribution of parking, it is anticipated that project traffic volume would also be evenly distributed traveling to/from the two parking areas. Trip assignment based on evenly distributed trips was added to the existing traffic volume to show the effect of the proposed project on surrounding roadways. The daily traffic volume on the surrounding roadway, without or with project traffic, is well within the typical daily traffic volume for local roadways.

Table 4.N: Roadway Traffic Volume

	Existing Daily Traffic	Project Daily Traffic	Existing Plus Project Daily Traffic
Carlton Avenue between Sydney Way and Keith Avenue	827	57	884
Lake Chabot Road between Fairmont Drive and Seven Hills Road	9,496	57	9,553
Miramar Avenue between Crest Avenue and Stanton Avenue	3,082	22	3,104
Stanton Avenue between Sydney Way and Miramar Avenue	1,510	102	1,612
Sydney Way between Stanton Avenue and Carlton Avenue	1,320	164	1,484

The project would create a new intersection on Sydney Way leading to the northern parking area and would add a fourth leg to the intersection of Carlton Avenue/Keith Avenue-Severini Lane leading to the eastern parking area. LSA also prepared a vehicle level of service (LOS) analysis of the two proposed project access intersections and two intersections in the vicinity of the project site to confirm satisfactory performance with the addition of project traffic. This LOS analysis was conducted using Highway Capacity Manual (HCM) methodology within Synchro traffic analysis software consistent with County standards. Existing intersection turn volume data was collected simultaneous with roadway traffic volume data. Cross traffic at the intersection of Northern Project Access/Sydney Way was developed from traffic volume data on Sydney Way. Project traffic volumes, based on evenly distributed traffic, during the AM and PM peak hour were overlaid on the existing traffic volumes to develop the existing plus project condition. Intersection LOS worksheets are provided in Appendix D. Table 4.O summarizes the analysis results.

Table 4.O: Vehicle Level of Service Summary

Intersection	Existing No Project				Existing Plus Project				Change With Project	
	AM Peak Hour		PM Peak Hour		AM Peak Hour		PM Peak Hour		AM	PM
	Delay (sec)	LOS	Delay (sec)	LOS	Delay (sec)	LOS	Delay (sec)	LOS		
1. Lake Chabot Road/Sydney Way	13.3	B	17.0	B	13.4	B	17.1	B	0.1	0.1
2. Stanton Avenue/Sydney Way ¹	9.9	A	9.2	A	10.0	B	9.3	A	0.1	0.1
3. Sydney Way/Project Access ¹	0.0	A	0.0	A	9.2	A	9.0	A	9.2	9.0
4. Carlton Avenue/Keith Avenue-Severini Lane ¹	9.0	A	8.8	A	9.2	A	9.0	A	0.2	0.2

Source: Compiled by LSA (2023) using Synchro 11 modeling software.

¹ Unsignalized intersection

LOS = level of service sec = seconds

As Table 4.O shows, the analyzed intersections operate at satisfactory LOS in the existing condition and are anticipated to continue to operate at satisfactory LOS with the addition of project traffic.

Because the project's trip generation is below the established threshold for providing additional traffic analysis, area roadways and intersections would continue to operate at satisfactory LOS, and the project would not interfere with transit, bicycle, or pedestrian facilities, the project would have a less than significant impact related to conflict with a program plan, ordinance or policy addressing the circulation system, including transit, roadway, bicycle and pedestrian facilities.

b. Would the project conflict or be inconsistent with CEQA Guidelines §15064.3, subdivision (b)? (Less-Than-Significant Impact)

CEQA Guidelines §15064.3, subdivision (b) seeks to evaluate a project's potential impact related to its vehicle miles traveled (VMT). Many jurisdictions that prepared guidelines for analysis of VMT that included exemptions for public facilities such as parks. Without formal published guidelines including screening thresholds from Alameda County, this analysis relies on The State of California Governor's Office of Planning and Research Technical Advisory On Evaluating Transportation Impacts in CEQA dated December 2018 (Technical Advisory).

The Technical Advisory provides examples of types of projects that should be expected to cause a less-than-significant impact related to VMT without conducting a detailed study. One of these screening thresholds is defined for projects generating fewer than 110 trips per day. As shown in Table 4.M, application of the ITE Trip Generation rates for park use would result in estimated trip generation far below this threshold.

The Technical Advisory also discusses how intervening land uses can redistribute existing trips resulting in shorter trips and a reduction in VMT. An example provided is retail uses less than 50,000 square feet. This example would generate over 2,000 daily trips but would have a less than significant impact related to VMT because, as an intervening use, each of those trips would be shorter. The proposed project is an intervening use and has the potential to shorten trips. The nearest dog parks to the project site are the Edendale Dog Park (located approximately 1.5 miles to the west) and the Earl Warren Dog Park (located approximately 3.0 miles to the east). While the total trip generation for the proposed project is anticipated to be 262 trips per day, these trips would be shorter than current trips taken to these next-nearest parks with dog parks.

The proposed project would present an intervening use and is anticipated to result in a redistribution of trips resulting in shorter trips. Therefore, in accordance with the Technical Advisory description of improved destination proximity, the project impacts related to CEQA Guidelines section 15064.3, subdivision (b) would be less than significant.

c. Would the project substantially increase hazards due to a geometric design feature (e.g., sharp curves or dangerous intersections) or incompatible uses (e.g., farm equipment)? (Less-Than-Significant Impact)

As mentioned previously, the proposed project would create two new parking areas to provide vehicle access from Sydney Way and Carlton Avenue. The project would also construct

bicycle/pedestrian and service vehicle entrances from Carlton Avenue and Stanton Avenue. Bicycle/pedestrian entrances would also be provided from Jennifer Drive and the existing residential community to the north. These access points would be constructed consistent with Alameda County design standards with signing and striping consistent with the California Manual on Uniform Traffic Control Devices (MUTCD). As shown in 4.O, the project access intersections are anticipated to operate at satisfactory LOS with the addition of project traffic. Therefore, the project would not create a hazard due to a geometric design feature or dangerous intersection. Travel modes to the proposed project, including pedestrian, bicycle, and automobile are compatible with a residential neighborhood. Therefore, the proposed project would result in a less than significant impact related to hazards associated with a design feature or incompatible uses.

d. Would the project result in inadequate emergency access? (Less-Than-Significant Impact)

The proposed project would provide access for emergency vehicles from Sydney Way, Stanton Avenue (at Perrich Avenue), and Carlton Avenue (at Severini Lane). As shown in Table 4.N, the proposed project would add a modest amount of traffic to roadways that operate within the daily traffic volume anticipated for local roadways; therefore, the proposed project would not alter or block adjacent roadways and would not impair the function of nearby emergency evacuation routes. The design, construction, and maintenance of project access locations and parking areas would be required to comply with County standards and would meet all emergency access standards. The Fire Department would also review the proposed site plan and would provide input on final design in relation to emergency access prior to issuance of a building permit. Therefore, the proposed project would not result in inadequate emergency access. This impact would be less than significant.

4.17 TRIBAL CULTURAL RESOURCES

	Potentially Significant Impact	Less Than Significant with Mitigation Incorporated	Less Than Significant Impact	No Impact
Would the project:				
a. Cause a substantial adverse change in the significance of a tribal cultural resource, defined in Public Resources Code Section 21074 as either a site, feature, place, cultural landscape that is geographically defined in terms of the size and scope of the landscape, sacred place, or object with cultural value to a California Native American tribe, and that is:				
i. Listed or eligible for listing in the California Register of Historical Resources, or in a local register of historical resources as defined in Public Resources Code Section 5020.1(k)? Or	<input type="checkbox"/>	<input type="checkbox"/>	<input checked="" type="checkbox"/>	<input type="checkbox"/>
ii. A resource determined by the lead agency, in its discretion and supported by substantial evidence, to be significant pursuant to criteria set forth in subdivision (c) of Public Resources Code Section 5024.1? In applying the criteria set forth in subdivision (c) of Public Resource Code Section 5024.1, the lead agency shall consider the significance of the resource to a California Native American tribe.	<input type="checkbox"/>	<input type="checkbox"/>	<input checked="" type="checkbox"/>	<input type="checkbox"/>

- a. Would the project cause a substantial adverse change in the significance of a tribal cultural resource, defined in Public Resources Code Section 21074 as either a site, feature, place, cultural landscape that is geographically defined in terms of the size and scope of the landscape, sacred place, or object with cultural value to a California Native American tribe, and that is:*
- i. Listed or eligible for listing in the California Register of Historical Resources, or in a local register of historical resources as defined in Public Resources Code Section 5020.1(k)? Or*
 - ii. A resource determined by the lead agency, in its discretion and supported by substantial evidence, to be significant pursuant to criteria set forth in subdivision (c) of Public Resources Code Section 5024.1? In applying the criteria set forth in subdivision (c) of Public Resource Code Section 5024.1, the lead agency shall consider the significance of the resource to a California Native American tribe. (Less-Than-Significant Impact)*

AB 52, which became law on January 1, 2015, provides for consultation with California Native American tribes during the CEQA environmental review process, and equates significant impacts to “tribal cultural resources” with significant environmental impacts. PRC Section 21074 states that “tribal cultural resources” are:

- Sites, features, places, cultural landscapes, sacred places, and objects with cultural value to a California Native American tribe and are one of the following:

- Included or determined to be eligible for inclusion in the California Register of Historical Resources.
- Included in a local register of historical resources as defined in subdivision (k) of PRC Section 5020.1.
- A resource determined by the lead agency, in its discretion and supported by substantial evidence, to be significant pursuant to criteria set forth in subdivision (c) of PRC Section 5024.1. In applying the criteria set forth in subdivision (c) of PRC Section 5024.1, the lead agency shall consider the significance of the resource to a California Native American tribe.

A “historical resource” (PRC Section 21084.1), a “unique archaeological resource” (PRC Section 21083.2(g)), or a “nonunique archaeological resource” (PRC Section 21083.2 (h)) may also be a tribal cultural resource if it is included or determined to be eligible for inclusion in the California Register.

The consultation provisions of the law require that a public agency consult with local Native American tribes that have requested placement on that agency’s notification list for CEQA projects. Within 14 days of determining that a project application is complete, or a decision by a public agency to undertake a project, the lead agency must notify tribes of the opportunity to consult on the project, should a tribe have previously requested to be on the agency’s notification list. California Native American tribes must be recognized by the California Native American Heritage Commission as traditionally and culturally affiliated with the project site and must have previously requested that the lead agency notify them of projects. Tribes have 30 days following notification of a project to request consultation with the lead agency.

The purpose of consultation is to inform the lead agency in its identification and determination of the significance of tribal cultural resources. If a project is determined to result in a significant impact on an identified tribal cultural resource, the consultation process must occur and conclude prior to adoption of a Negative Declaration or Mitigated Negative Declaration, or certification of an Environmental Impact Report (PRC Sections 21080.3.1, 21080.3.2, 21082.3).

On January 24, 2023, HARD sent AB 52 outreach letters to the tribes listed in the contact list provided by the Native American Heritage Commission (NAHC) on March 24, 2022. The letters, sent via certified mail to the tribal contacts, described the project, provided maps of the project site, and invited the tribes to request consultation should they have any concerns. On February 24, 2023, Corrina Gould, Tribal Chair of the Confederated Villages of Lisjan Nation responded by email to request additional information regarding the project site and the results of the Sacred Lands File search. HARD responded via email on February 28, 2023. To date, consultation is ongoing.

As discussed in Section 4.5, Cultural Resources, the NWIC records search and the archaeological survey completed for the project did not identify evidence of Native American archaeological deposits or ancestral remains. The proposed project would have no impact on known tribal cultural resources that are listed or eligible for listing in the California Register of Historical Resources or a local register of historical resources, nor has HARD identified a tribal cultural resource at the project site. As noted in Section 4.5, Cultural Resources, implementation of Mitigation Measure CULT-1

would ensure that potential impacts related to previously undiscovered historic or archaeological resources, which are considered tribal cultural resources, would be less than significant.

4.18 UTILITIES AND SERVICE SYSTEMS

	Potentially Significant Impact	Less Than Significant with Mitigation Incorporated	Less Than Significant Impact	No Impact
Would the project:				
a. Require or result in the relocation or construction of new or expanded water, wastewater treatment or stormwater drainage, electric power, natural gas, or telecommunications facilities, the construction or relocation of which could cause significant environmental effects?	<input type="checkbox"/>	<input type="checkbox"/>	<input checked="" type="checkbox"/>	<input type="checkbox"/>
b. Have sufficient water supplies available to serve the project and reasonably foreseeable future development during normal, dry and multiple dry years?	<input type="checkbox"/>	<input type="checkbox"/>	<input checked="" type="checkbox"/>	<input type="checkbox"/>
c. Result in a determination by the wastewater treatment provider which serves or may serve the project that it has adequate capacity to serve the project's projected demand in addition to the provider's existing commitments?	<input type="checkbox"/>	<input type="checkbox"/>	<input checked="" type="checkbox"/>	<input type="checkbox"/>
d. Generate solid waste in excess of State or local standards, or in excess of the capacity of local infrastructure, or otherwise impair the attainment of solid waste reduction goals?	<input type="checkbox"/>	<input type="checkbox"/>	<input checked="" type="checkbox"/>	<input type="checkbox"/>
e. Comply with federal, state, and local management and reduction statutes and regulations related to solid waste?	<input type="checkbox"/>	<input type="checkbox"/>	<input checked="" type="checkbox"/>	<input type="checkbox"/>

A variety of local and regional purveyors in the area provide and maintain utility and service system facilities associated with water, stormwater, wastewater, solid waste, communications, electricity, and natural gas.

a. Would the project require or result in the relocation or construction of new or expanded water, wastewater treatment or stormwater drainage, electric power, natural gas, or telecommunications facilities, the construction or relocation of which could cause significant environmental effects? (Less-Than-Significant Impact)

Water. The East Bay Municipal Utility District (EBMUD) provides water service at the project site. EBMUD's water service system consists of a network of reservoirs, aqueducts (pipelines), water treatment plants (WTP), pumping plants, and other distribution facilities and pipelines that convey Mokelumne River water from Pardee Reservoir to EBMUD customers.⁶¹ The water distribution network includes 4,200 miles of pipe, 131 pumping plants, and 167 water distribution reservoirs. EBMUD has water rights for up to 325 million gallons per day (mgd) from the Mokelumne River watershed.⁶² Castro Valley is served by the Upper San Leandro/Orindo Water Treatment Plant.⁶³ According to the Alameda County 2000 General Plan, EBMUD has determined that it has sufficient system capacity to serve growth anticipated in the Castro Valley area through 2030.

⁶¹ East Bay Municipal Utility District (EBMUD). 2021b. *Urban Water Management Plan, Public Draft*. April.

⁶² Ibid.

⁶³ Alameda County Community Development Agency. 2012. *Castro Valley Area General Plan*. March.

The proposed project would include the installation of a drinking fountain, restroom and fire hydrants and some of the landscaped areas may require limited irrigation until plants are established. Existing utilities are located under and along all streets adjacent to the project site, and the park's needs for irrigation, drinking fountains, restrooms, and fire hydrants would be served by a new water line that would connect to existing utilities under Sydney Way. The new water line would be constructed in conformance with County standards, and its construction would not cause significant environmental effects.

Wastewater. Wastewater treatment service in the Castro Valley Area is provided by two sanitation districts: Castro Valley Sanitation District (CVSD) and Oro Loma Sanitary District (OLSD). The CVSD provides and maintains the sewage collection system that serves most of Castro Valley, including at the project site. The OLSD provides the sewage collection systems for the Hillcrest Knolls and El Portal Ridge neighborhoods.⁶⁴

The Oro Loma Sanitary District/Castro Valley Sanitary District Water Pollution Control Plant (WPCP), located on Grant Avenue, handles most of the wastewater from the Castro Valley Area. The WPCP has a permitted capacity of 20.0 mgd and treats an average dry weather flow of 12.4 mgd.⁶⁵ Therefore, the WPCP has a minimum available capacity of approximately 7.6 mgd. The CVSD sewer collection system includes 8 wastewater pump stations and approximately 160 miles of wastewater sewer lines.

The proposed project would include the construction of a new restroom on the project site that would contribute to wastewater generation at the project site. Existing utilities are located under and along all streets adjacent to the project site, and the proposed restrooms would be served by a new wastewater line that would connect to existing utilities under Sydney Way. The final size of these facilities would be determined prior to issuance of a grading permit. The new sanitary sewer line would be constructed in conformance with County standards, and its construction would not cause significant environmental effects.

Stormwater. Drainage and flood control in the Castro Valley Area is the responsibility of the Alameda County Flood Control and Water Conservation District, which has adopted plans to serve cities within the County, as well as the unincorporated areas. Castro Valley is located in Flood Control Zone 2 where there are 81 miles of natural creek, five miles of earth channel, 12 miles of concrete channel, two miles of improve channel, 44 miles of underground pipe, and two pump stations. In addition, there are two reservoirs, Cull Canyon and Don Castro, which are maintained for flood control. In the Castro Valley Area, stormwater flows down from Castro Valley and the Hayward hills to storm drains, channels, and pipelines leading to San Lorenzo Creek and on to the San Francisco Bay. Surface water runoff drains to Sulphur Creek, Estudillo Canal (located in San Leandro), San Lorenzo Creek, or Bockman Canal, and eventually to the San Francisco Bay.⁶⁶

⁶⁴ Alameda County Community Development Agency. 2012. *Castro Valley Area General Plan*. March.

⁶⁵ Castro Valley Sanitary District. 2023. Wastewater. <https://www.cvsan.org/wastewater/index.php>. (accessed January 13, 2023).

⁶⁶ Alameda County Community Development Agency. 2012. op. cit.

Under existing conditions, drainage from the site has been addressed through a variety of techniques implemented by adjacent property owners. Because the proposed site plan would involve minimal changes to existing drainage patterns, only certain areas would require comprehensive stormwater management. Storm drain connections would be developed along both vehicular access points and permeable surfacing and swales would be used to support infiltration and groundwater recharge. In locations where vegetated screens would be planted for privacy, an earthen swale could be incorporated to help divert surface water.

As part of the project, HARD would prepare a Storm Water Mitigation Plan (to identify permanent stormwater controls) and an SWPPP (to identify temporary construction of stormwater controls) in compliance with existing stormwater protection requirements. Therefore, the proposed project would not require or result in the construction of new stormwater drainage facilities, or the expansion of existing facilities and this impact would be less than significant.

Electricity, Natural Gas, and Telecommunications. East Bay Community Energy (EBCE) provides electricity to residential and commercial properties in the Castro Valley Area. Operation of the proposed park would result in no change to existing natural gas or telecommunications usage, as no such facilities would be constructed or required as part of park development. As described in Section 2.0, Project Description, lighting is proposed to promote security and safety for park users. Proposed lighting would tie into existing electric utilities and is not anticipated to generate substantial additional demand such that new facilities or expansion of facilities would be required. Therefore, the proposed project would not require or result in the relocation or construction of new or expanded gas, electricity or telecommunications facilities. This impact would be less than significant.

b. Have sufficient water supplies available to serve the project and reasonably foreseeable future development during normal, dry and multiple dry years? (Less-Than-Significant Impact)

Water service at both the project site and in the project area is provided by EBMUD. EBMUD obtains approximately 90 percent of its water from the Mokelumne River watershed and transports it through pipe aqueducts to temporary storage reservoirs in the East Bay hills. EBMUD has water rights and facilities to divert up to a daily maximum of 325 mgd from the Mokelumne River. Average daily water demand within the entire EBMUD service area is projected to be 245 mgd in 2025, and 297 mgd in 2050.⁶⁷

The proposed project would increase water demands at the project site due to the construction of the construction of a drinking fountain, restroom, and fire hydrants. Proposed landscaping would be either native species or drought tolerant species for water conservation; however, some of the landscaped areas may require limited irrigation until plants are established. The irrigation system would be designed to minimize water use and be adapted to weather conditions. The proposed project is anticipated to generate a water demand of approximately 10,000 gallons per year (.00002 mgd). This additional water demand would account for approximately 0.00008 percent of EBMUD's daily water capacity.

⁶⁷ East Bay Municipal Utility District (EBMUD). 2021b. op. cit.

EBMUD completed development of a revised *Water Supply Management Program (WSMP) 2040* in April of 2012, which is the Utility District's plan for providing water to its customers for a span of 30 years.⁶⁸ According to the WSMP, EBMUD's water supplies are estimated to be sufficient during the planning period (2010–2040) in normal and single dry years. Therefore, EBMUD would have adequate water supply to provide water service to the proposed project, and the impacts related to sufficient water supplies would be less than significant.

The WSMP 2040 emphasizes maximum conservation and recycling strategies, with a total of 50 mgd of future supply to be provided from those two component categories. However, looking toward 2040, EBMUD's current supply is insufficient to meet customer needs during multi-year droughts despite EBMUD's aggressive water conservation and recycled water programs.⁶⁹ According to the WSMP, the combination of rationing, conservation, and raw and recycled water would satisfy increased customer demand through 2040.⁷⁰ Supplemental supply would also be needed to keep rationing at a lower level and to meet the need for water in drought years. EBMUD also imposes a system capacity charge on new developments to fund system maintenance and the development of new water sources. HARD would be required to pay this fee and undertake water conservation measures to conserve water. In extreme drought years, the new residential units associated with the proposed project would likely be subject to and participate in conservation measures. For these reasons, the impact related to sufficient water supplies during dry and multiple dry years would be less than significant.

c. Would the project result in a determination by the wastewater treatment provider, which serves or may serve the project that it has adequate capacity to serve the project's projected demand in addition to the provider's existing commitments? (Less-Than-Significant Impact)

As discussed in Section 4.19a, the proposed project would involve the construction of a restroom on the project site, which would generate a minimal amount of wastewater. The proposed project is anticipated to generate approximately 10,000 gallons per year (.00002 mgd) of wastewater. This additional wastewater would account for approximately 0.0016 percent of the WPCP's average dry weather flow. Considering approximately 70 percent of the allowable capacity for CVSD is treated on a daily basis, the treatment plant would have sufficient capacity to serve the proposed project. Therefore, this impact would be less than significant.

d. Would the project generate solid waste in excess of State or local standards, or in excess of the capacity of local infrastructure, or otherwise impair the attainment of solid waste reduction goals? (Less-Than-Significant Impact)

Solid waste and recycling collection service and programming in the Castro Valley Area is overseen by the Alameda County Waste Management Authority (ACWMA). The CVSD and the OLSD handle refuse collection and disposal within the Castro Valley area. The Districts collected solid waste, and generally haul it to the Davis Street Transfer Station, and then to the Altamont Landfill Resource Recovery Facility east of Livermore which has contracted with the ACWMA. Operating landfills in

⁶⁸ East Bay Municipal Utility District (EBMUD). 2012. *Water Supply Management Program 2040 Plan*. April.

⁶⁹ East Bay Municipal Utility District (EBMUD). 2020. *Water Shortage Contingency Plan 2020*. June 22.

⁷⁰ East Bay Municipal Utility District (EBMUD). 2012. op. cit.

Alameda County include the Altamont Landfill Resource Recovery Facility near Altamont Pass and the Vasco Road Landfill north of Livermore. The Altamont Landfill Resource Recovery Facility has a maximum daily permitted throughput of 11,150 tons per day and a remaining capacity of approximately 65.4 million cubic yards.⁷¹ The Altamont Landfill's estimated closure date is currently December 2070. The project site is located within the CVSD.

Operation of the proposed project is not anticipated to generate a significant amount of solid waste. Users of the proposed park and other recreation facilities at the project site would dispose of garbage, but not in amounts that would greatly exceed average per capita garbage generation rates. In addition, recycling receptacles would be located throughout the park, allowing the proposed project to be in full compliance with waste diversion goals mandated by the California Integrated Waste Management Act. Solid waste disposal off-site would comply with all local, State, and federal requirements. Therefore, the proposed project would be served by a landfill with sufficient permitted capacity to accommodate the project's solid waste disposal needs, and this impact would be less than significant.

e. Would the project comply with federal, state, and local statutes and regulations related to solid waste? (No Impact)

The California Integrated Waste Management Act of 1989 (AB 939) reorganized solid waste disposal planning within the State of California. The legislation required every county to adopt a Countywide Integrated Waste Management Plan (ColWMP) describing local waste diversion and disposal conditions as well as create programs to meet State goals for diverting waste from landfills. A mandatory diversion goal was established diverting 25 percent of waste from landfills by 1995 and 50 percent by 2000 and maintaining 50 percent thereafter.

Alameda County is a member agency of the Alameda County Waste Management Authority Board, a public agency that is responsible for preparation of the Alameda County ColWMP. First adopted in 1997, the ColWMP was most recently updated in April 2020 and established a countywide goal of 75 percent waste diversion from landfills compared to 1990 and a 75 percent reduction in organics from landfills compared to 2014.⁷² The proposed project would comply with all regulations outlined in the ColWMP, as well as any other federal, State, and local statutes and regulations related to solid wastes, including waste diversion programs. No impact related to this topic would occur as a result of implementation of the proposed project. Please refer to Section 3.19d.

⁷¹ CalRecycle. 2019. Facility/Site Summary Details: Altamont Landfill & Resource Recovery (01-AA-0009). Website: www2.calrecycle.ca.gov/SolidWaste/SiteActivity/Details/7?siteID=7 (Accessed January 13, 2023).

⁷² Alameda County Waste Management Authority. 2020. Alameda County Integrated Waste Management Plan. April 22..

4.19 WILDFIRE

	Potentially Significant Impact	Less Than Significant with Mitigation Incorporated	Less Than Significant Impact	No Impact
If located in or near state responsibility areas or lands classified as very high fire hazard severity zones, would the project:				
a. Substantially impair an adopted emergency response plan or emergency evacuation plan?	<input type="checkbox"/>	<input type="checkbox"/>	<input checked="" type="checkbox"/>	<input type="checkbox"/>
b. Due to slope, prevailing winds, and other factors, exacerbate wildfire risks, and thereby expose project occupants to pollutant concentrations from a wildfire or the uncontrolled spread of a wildfire?	<input type="checkbox"/>	<input type="checkbox"/>	<input checked="" type="checkbox"/>	<input type="checkbox"/>
c. Require the installation or maintenance of associated infrastructure (such as roads, fuel breaks, emergency water sources, power lines or other utilities) that may exacerbate fire risk or that may result in temporary or ongoing impacts to the environment?	<input type="checkbox"/>	<input type="checkbox"/>	<input checked="" type="checkbox"/>	<input type="checkbox"/>
d. Expose people or structures to significant risks, including downslope or downstream flooding or landslides, as a result of runoff, post-fire slope instability, or drainage changes?	<input type="checkbox"/>	<input type="checkbox"/>	<input checked="" type="checkbox"/>	<input type="checkbox"/>

a. Would the project substantially impair an adopted emergency response plan or emergency evacuation plan? (Less-Than-Significant Impact)

As described in Section 4.9.f, the proposed project is located within a Very High Fire Hazard Severity Zone (VHFHSZ) within a local responsibility area. Current State law requires that all property within the Local Responsibility Area VHFHSZ must maintain 100 feet of defensible space.

As previously discussed in Section 4.9.g, the proposed project would be consistent with the policies outlined in the Alameda County General Plan Safety Element and the *Castro Valley General Plan* Natural Hazards and Public Safety Element. The proposed project would not alter or block adjacent roadways, and implementation of the proposed project would not be expected to impair the function of nearby roads that might be used for evacuation during an emergency. In addition, operation of the proposed project would not cause permanent alterations to vehicle circulation routes and patterns or impede public access or travel upon public rights-of-way. Therefore, the proposed project would not interfere with an adopted emergency response plan or emergency evacuation plan. Impacts would be less than significant.

b. Would the project, due to slope, prevailing winds, and other factors, exacerbate wildfire risks, and thereby expose project occupants to pollutant concentrations from a wildfire or the uncontrolled spread of a wildfire? (Less-Than-Significant Impact)

As described in Section 4.7, Geology and Soils, elevations on the project site range from approximately 340 to 420 feet above sea level. Prevailing winds are typically from the west between February and November and from the north from November to February in Castro Valley.

The proposed project would consist of development of a neighborhood park within an existing residential neighborhood. As noted in Section 3.9, Hazards and Hazardous Materials, the proposed project does not involve construction of residential or commercial structures or any other structures for human occupation (Section 3.9.g) and people would use the park for a limited duration of time. The operation of the proposed project would be consistent with surrounding residential uses and allowable zoning for the project site.

Construction of the proposed project would involve the use of some flammable materials such as gasoline, diesel fuel, hydraulic oils, paints, solvents, or other wastes. During construction, there would be increased human activity and ignition sources, including equipment that could create spark, be a source of heat, or leak flammable materials on the project site. However, all construction equipment is required to have fire suppression equipment (such as a fire extinguisher) on board or at the work site, secondary containment would be required for fuel-powered equipment, and a spill kit would be required to be kept on-site during construction for use in case of any leaks or spills of flammable materials. These existing requirements would reduce the potential exacerbation of wildfire risks related to construction activities.

Additionally, the project would be required to comply with the Uniform Fire Code (Section 6.04 of the County Ordinance Code) and the Building Code (Title 15), which call for the installation, maintenance, and ongoing inspection of fire protection systems under the direction of the local Fire Chief. In addition, the Uniform Fire Code authorizes the Fire Chief to specify water supply and road design standards. Additionally, Chapter 6.44 of the County's General Ordinance prohibits vegetation that may increase fire hazards. Prior to approval of improvement plans for any development project within Castro Valley, plan review and approval by the Alameda County Fire District would be required.

Consistent with Alameda County General Plan Policies P1-P12 of Section 3.3 of the Safety Element, the proposed project would be required to implement the following: fuel breaks and vegetation management programs; use of fire retardant building materials and landscaping; visible street signs; provision of adequate water supply and fire protection facilities and services; adherence with provisions of the Alameda County Fire Protection Master Plan and Fire Hazard Mitigation Plan; appropriate siting and design to minimize risks to life and property; and safe access for emergency response vehicles.

Compliance with these existing regulatory requirements would ensure that the proposed project would not exacerbate wildfire risks, and thereby expose project occupants to pollutant concentrations from a wildfire or the uncontrolled spread of a wildfire. Impacts would be less than significant.

- c. *Would the project require the installation or maintenance of associated infrastructure (such as roads, fuel breaks, emergency water sources, power lines or other utilities) that may exacerbate fire risk or that may result in temporary or ongoing impacts to the environment? (Less-Than-Significant Impact)*

As noted above, the proposed project would include development of a community park within an existing residential neighborhood. Associated improvements would include access improvements and utility connections. Utility connections/lines would be constructed in conformance with County standards as detailed in Section 4.19, Utilities and Service Systems. The project does not propose the installation or maintenance of any other associated infrastructure (such as roads, fuel breaks, emergency water sources, power lines or other utilities) that may exacerbate fire risk or that may result in temporary or ongoing impacts to the environment, and impacts would be less than significant.

- d. *Would the project expose people or structures to significant risks, including downslope or downstream flooding or landslides, as a result of runoff, post-fire slope instability, or drainage changes? (Less-Than-Significant Impact)*

Construction of the proposed project would be required to obtain coverage under the National Pollutant Discharge Elimination System (NPDES) General Construction stormwater permit. As discussed in Section 4.10, Hydrology and Water Quality, the proposed project would implement a Stormwater Pollution and Prevention Plan (SWPPP) that specifies Best Management Practices (BMPs) and erosion control measures to be used during construction to manage runoff flows. Additionally, the proposed project would not significantly alter drainage patterns compared to existing conditions. Furthermore, the project site is not located within a flood zone. As described in Section 4.7, Geology and Soils, two small, past landslides were identified on the project site. The proposed project would include the use of fiber roll, jute netting and hydroseeded planting specified for steep, unirrigated slopes on the west side of the hill in the center of the site and in the northwest corner of the site to stabilize slopes. Implementation of the recommendations outlined in the Geotechnical Investigation Report, incorporation of slope stabilization measures into the proposed project, and compliance with the CBC during design and construction. Therefore, the proposed project would not have the potential to expose people or structures to downslope or downstream flooding or landslides as a result of post-fire slope instability or drainage changes. This impact would be less than significant.

4.20 MANDATORY FINDINGS OF SIGNIFICANCE

	Potentially Significant Impact	Less Than Significant with Mitigation Incorporated	Less Than Significant Impact	No Impact
a. Does the project have the potential to substantially degrade the quality of the environment, substantially reduce the habitat of a fish or wildlife species, cause a fish or wildlife population to drop below self-sustaining levels, threaten to eliminate a plant or animal community, substantially reduce the number or restrict the range of a rare or endangered plant or animal or eliminate important examples of the major periods of California history or prehistory?	<input type="checkbox"/>	<input checked="" type="checkbox"/>	<input type="checkbox"/>	<input type="checkbox"/>
b. Does the project have impacts that are individually limited, but cumulatively considerable? ("Cumulatively considerable" means that the incremental effects of a project are considerable when viewed in connection with the effects of past projects, the effects of other current projects, and the effects of probable future projects.)	<input type="checkbox"/>	<input checked="" type="checkbox"/>	<input type="checkbox"/>	<input type="checkbox"/>
c. Does the project have environmental effects which will cause substantial adverse effects on human beings, either directly or indirectly?	<input type="checkbox"/>	<input type="checkbox"/>	<input type="checkbox"/>	<input checked="" type="checkbox"/>

a. Does the project have the potential to substantially degrade the quality of the environment, substantially reduce the habitat of a fish or wildlife species, cause a fish or wildlife population to drop below self-sustaining levels, threaten to eliminate a plant or animal community, substantially reduce the number or restrict the range of a rare or endangered plant or animal or eliminate important examples of the major periods of California history or prehistory? (Less-Than-Significant with Mitigation Incorporated)

Implementation of the mitigation measures recommended in this IS/MND would ensure that the construction and operation of the proposed project would not substantially degrade the quality of the environment; reduce the habitat, population, or range of a plant or animal species; or eliminate important examples of California history or prehistory. As discussed in Section 3.4, Biological Resources, several special-status animal species, including burrowing owl, northern harrier, golden eagle, white-tailed kite, grasshopper sparrow, loggerhead shrike, nesting birds, roosting bats, San Francisco dusky-footed woodrat, Monarch butterfly, Crotch bumble bee and western bumble bee, have the potential to occur within the project site due to the presence of potentially suitable habitat and known occurrence records in the project vicinity. The biological resource search identified nine special-status plant species that could occur within the project site based on the presence of potentially suitable habitat. With implementation of **Mitigation Measures BIO-1** through **BIO-6**, potential impacts to special-status species (flora and fauna) would be reduced to less than significant levels.

As discussed in Section 4.5, Cultural Resources, the proposed project is not expected to result in any significant impacts to any examples of the major periods of California history or prehistory. No historic cultural or archaeological resources as defined by CEQA were identified in the study area. However, given the historic-period development of the buildings within the project site, the

proximity of the project site to unnamed creeks, and the types of sediments mapped in the project site, implementation of the project has potential to impact subsurface cultural resources dating to either the historic period or the precontact period. With implementation of **Mitigation Measure CUL-1**, which requires monitoring of initial ground disturbing activities and measures to be implemented if resources are found, potential impacts to cultural resources would be reduced to less than significant levels.

With implementation of these mitigation measures, the proposed project would result in less than significant impacts to the quality of the environment. No additional mitigation is required.

b. Does the project have impacts that are individually limited, but cumulatively considerable? ("Cumulatively considerable" means that the incremental effects of a project are considerable when viewed in connection with the effects of past projects, the effects of other current projects, and the effects of probable future projects)? (Less-Than-Significant with Mitigation Incorporated)

The *State CEQA Guidelines* require a discussion of significant environmental impacts that would result from project-related actions in combination with "closely related past, present, and probably future projects: located in the immediate vicinity" (*State CEQA Guidelines* Section 15130[b][1][A]). Cumulative environmental impacts are those impacts that by themselves are not significant, but when considered with impacts occurring from other projects in the vicinity would result in a cumulative impact. Related projects considered to have the potential of creating cumulative impacts in association with the proposed project consist of projects that are reasonably foreseeable and that would be constructed or operated during the life of the proposed project.

The proposed project would be located in a highly developed urban area that is largely built out. No other construction projects are anticipated in the immediate area of the project within this timeframe. The proposed project's impacts would be individually limited and not cumulatively considerable. The potentially significant impacts that can be reduced to a less than significant level with implementation of recommended mitigation measures include the topics of air quality, biological resources, cultural resources, geology and soils, hazardous materials, and noise. These impacts would primarily be related to construction-period activities, would be temporary in nature, and would not substantially contribute to any potential cumulative impacts associated with these topics. For the topic of air quality, potentially significant impacts to air quality standards associated with project construction would be reduced to less than significant levels with implementation of Mitigation Measure AIR-1. For the topic of biological resources, implementation of Mitigation Measures BIO-1a through BIO-6 would ensure that impacts to special-status species, including Alameda whipsnake, white-tailed kite, nesting birds, roosting bats, San Francisco dusky-footed wood rat, Monarch butterfly, Crotch bumble bee, and western bumble bee are reduced to a less than significant level. For the topic of cultural resources, potentially significant impacts to archaeological and cultural resources would be reduced to less than significant levels with implementation of Mitigation Measure CULT-1. For the topic of geology and soils, implementation of Mitigation Measure GEO-1 would ensure that impacts to paleontological resources are reduced to less than significant levels. For the topic of hazards and hazardous materials, implementation of Mitigation Measure HAZ-1 would ensure that potential impacts associated with hazardous materials in site soils would be reduced to a less than significant level. For the topic of construction noise, implementation

of Mitigation Measure NOI-1 would ensure that sensitive noise receptors are not impacted during project construction activities.

For the topics of aesthetics, agricultural and forestry resources, energy, greenhouse gas emissions, hydrology and water quality, land use and planning, mineral resources, population and housing, public services, recreation, transportation, tribal cultural resources, utilities and service systems, and wildfire, the project would have no impacts or less than significant impacts and, therefore, would not substantially contribute to any potential cumulative impacts for these topics. All environmental impacts that could occur as a result of the proposed project would be reduced to a less than significant level through the implementation of the mitigation measures recommended in this document.

Implementation of these measures would ensure that the impacts of the project would be below established thresholds of significance and that these impacts would not combine with the impacts of other cumulative projects to result in a cumulatively considerable impact on the environment as a result of project development. Therefore, this impact would be less than significant with mitigation incorporated.

c. Does the project have environmental effects which will cause substantial adverse effects on human beings, either directly or indirectly? (No Impact)

The proposed project would not result in environmental effects that would cause substantial direct or indirect adverse effects to human beings. No impacts would occur.

This page intentionally left blank

5.0 LIST OF PREPARERS

LSA Associates, Inc.

Theresa Wallace, AICP, Principal in Charge
Shanna Guiler, AICP, Associate, Project Manager
Lauren Peachy, Assistant Environmental Planner
Amy Fischer, Principal/Air Quality and Noise Specialist
Cara Cunningham, Associate Air Quality and Noise Specialist
Dan Sidle, Associate Biologist
Kerrie Collison, Associate/Senior Cultural Resources Manager
JT Stephens, Principal Noise Specialist
Moe Abushanab, Noise Specialist

This page intentionally left blank

6.0 REFERENCES

- ACC Environmental Consultants. 2019. *Phase 1 Environmental Site Assessment*. December 18.
- Alameda County. *Scenic Route Element of the Alameda County General Plan*. May 1966 (as amended May 1994).
- Alameda County. 2016a. Ordinance No. O-2016-66, amending Chapter 12.11 of Title 12 of the Alameda County General Ordinance Code. December 6.
- Alameda County. 2016b. *County of Alameda 2016 Local Hazard Mitigation Plan*. October.
- Alameda County Community Development Agency. 2012. *Castro Valley General Plan*. March.
- Alameda County Community Development Agency, *Zoning Viewer Public Access Map (PAM)*. (Accessed January 6, 2023)
- Alameda County Fire Department. Alameda County Fire Department website: <https://fire.acgov.org>. (accessed January 6, 2023)
- Alameda County Sheriff's Office of Homeland Security and Emergency Services. 2012. *Alameda County Emergency Operation Plan*. Available online at: www.acgov.org/ready/documents/EmergencyOperationsPlan.pdf. (Accessed January 12, 2023).
- Alameda County Sheriff's Office. 2019. Community Capitals Policing, A New Brand of Public Safety presentation. Available online at: www.acgov.org/board/bos_calendar/documents/DocsAgendaReg_1_10_19/GENERAL%20ADMINISTRATION/Regular%20Calendar/Community_capitals_policing_1_10_19.pdf. (Accessed January 6, 2023).
- Alameda County Waste Management Authority. 2020. Alameda County Integrated Waste Management Plan. April 22.
- American Ornithologists' Union (AOU). 1998. Check-list of North American Birds. 7th Edition. American Ornithologists' Union, Washington, D.C.
- Bay Area Air Quality Management District (BAAQMD). 2017a. *Clean Air Plan*. April 19.
- Bay Area Air Quality Management District (BAAQMD). 2017b. California Environmental Quality Act Air Quality Guidelines. May.
- Bay Area Air Quality Management District (BAAQMD). 2022. *Justification Report: CEQA Thresholds for Evaluating the Significance of Climate Impacts From Land Use Projects and Plans*. April.

- Baldwin, B.G., D.H. Goldman, D.J. Keil, R. Patterson, T.J. Rosatti, and D.H. Wilken, editors. 2012. *The Jepson Manual: Vascular Plants of California*, Second Edition. University of California Press, Berkeley.
- Bradley, R.D., L.K. Ammerman, R.J. Baker, L.C. Bradley, J.A. Cook, R.C. Dowler, D.J. Schmidly, F.B. Stangl, Jr., R.A. Van Den Bussche, and B. Würsig. 2014. Revised Checklist of North American Mammals North of Mexico, 2014. Occasional Papers, Museum of Texas Tech University No. 237.
- BSK Associates. *Preliminary Geotechnical Investigation Report Valley View Park Project Castro Valley, California*. March 24, 2020.
- California Department of Conservation (DOC). *Alameda County Tsunami Hazard Areas*. Website: <https://www.conservation.ca.gov/cgs/tsunami/maps/alameda> (accessed March 21, 2023).
- California Department of Conservation (DOC), Division of Mine Reclamation, *Mines Online Mapper*. (Accessed January 6, 2023)
- California Department of Conservation (DOC). 2016. California Important Farmland Finder. Website: maps.conservation.ca.gov/dlrp/ciff (accessed January 5, 2023).
- California Department of Conservation (DOC). 2019. Alquist-Priolo Earthquake Fault Zones. Website: www.conservation.ca.gov/cgs/alquist-priolo (accessed December 16 2022).
- Cal. Building Industry Assn. v. Bay Area Air Quality Mgmt. Dist. (2015) 62 Cal.4th 369, 386
- California Department of Fish and Wildlife (CDFW). 2018. Protocols for Surveying and Evaluating Impacts to Special Status Native Plant Populations and Sensitive Natural Communities. State of California, California Natural Resources Agency. March 20.
- California Department of Fish and Wildlife (CDFW). 2019. Evaluation of the Petition from the Xerces Society, Defenders of Wildlife, and the Center for Food Safety to List Four Species of Bumble Bees as Endangered Under the California Endangered Species Act.
- California Department of Fish and Wildlife (CDFW). 2023. California Natural Diversity Database, commercial version dated February 2023. Biogeographic Data Branch, California Department of Fish and Wildlife, Sacramento.
- California Department of Water Resources (DWR). DWR Mapping Tool. Website: <https://sgma.water.ca.gov/webgis/index.jsp?appid=gasmaster&rz=true> (accessed March 2023).
- California Energy Commission (CEC). 2015. Medium and Heavy-Duty Truck Prices and Fuel Economy 2013–2026. Website: efiling.energy.ca.gov/getdocument.aspx?tn=206180 (accessed March 2023).

- California Energy Commission (CEC). 2022. *2022 Integrated Energy Policy Report Update*. Website: <https://www.energy.ca.gov/data-reports/reports/integrated-energy-policy-report/2022-integrated-energy-policy-report-update> (accessed March 2023).
- California Native Plant Society, Rare Plant Program. 2023. Rare Plant Inventory (online edition, v9.5). Website <https://www.rareplants.cnps.org> [accessed February 21].
- California State Mining and Geology Board. 2014. Surface Mining Reclamation Act Regulations. California Code of Regulations, Title 14, Division 2, Chapter 8, Subchapter 1.
- CalRecycle. 2019. Facility/Site Summary Details: Altamont Landfill & Resource Recovery (01-AA-0009). Website: www2.calrecycle.ca.gov/SolidWaste/SiteActivity/Details/?siteID=7 (Accessed January 13, 2023).
- Castro Valley Sanitary District. 2023. Wastewater. <https://www.cvsan.org/wastewater/index.php>. (accessed January 13, 2023).
- Castro Valley Unified School District. *Schools*. Castro Valley Unified School District website:<https://www.cv.k12.ca.us>. (accessed January 6, 2023).
- Crother, B.I. (ed.). 2017. Scientific and Standard English Names of Amphibians and Reptiles of North America North of Mexico, with Comments Regarding Confidence in Our Understanding, pp. 1-102. SSAR Herpetological Circular No. 43.
- East Bay Municipal Utility District (EBMUD). 2012. *Water Supply Management Program 2040 Plan*. April.
- East Bay Municipal Utility District (EBMUD). 2020. *Water Shortage Contingency Plan 2020*. June 22.
- East Bay Municipal Utility District (EBMUD). 2021a. Water Supply. Website: www.ebmud.com/water/about-your-water/water-supply (accessed August 2022)
- East Bay Municipal Utility District (EBMUD). 2021b. *Urban Water Management Plan, Public Draft*. April.
- eBird. 2023a. eBird: An online database of bird distribution and abundance [web application]. Cornell Lab of Ornithology.
- eBird. 2023b. *Species Lists for Lake Chabot Regional Park eBird Hotspots, Alameda County, California*.
- Federal Emergency Management Agency (FEMA), 2009. Flood Insurance Rate Map (FIRM) No. 06001C0278G, effective August 3. Website: <https://msc.fema.gov/portal/search?AddressQuery=sydney%20way%2C%20castro%20valley%2C%20ca#searchresultsanchor> (accessed March 21, 2023).

- Federal Transit Administration. 2018. *Transit Noise and Vibration Impact Assessment Manual FTA Report No. 0123*. September.
- FirstCarbon Solutions. 2015. Biological Resources Constraints Report, EBMUD Parcel/Future Park Site, Castro Valley, Alameda County, California. Prepared for the Hayward Area Recreation and Park District. February 13.
- Hayward Area Recreation and Park District. 2023. *Valley View Park Master Plan*.
- Jepson Flora Project. 2023. Jepson eFlora. Website: ucjeps.berkeley.edu/eflora/
- State Water Resources Control Board (SWRCB). 2009. Division of Water Quality. *Construction General Permit Fact Sheet*. 2009-0009-DWQ amended by 2010-0014-DWQ & 2012-0006-DWQ. Website: https://www.waterboards.ca.gov/water_issues/programs/stormwater/docs/constpermits/wqo_2009_0009_factsheet.pdf (accessed August 2022).
- State Water Resources Control Board. 2022. National Pollutant Discharge Elimination System (NPDES) General Permit for Stormwater Discharges Associated with Construction and Land Disturbance Activities (Order No. 2022-0057-DWQ, NPDES No. CAS000002)
- State Water Resources Control Board. 2023. *2020-2022 California Integrated Report (Clean Water Act Section 303(d) List and 305(b) Report)*. Website: https://www.waterboards.ca.gov/water_issues/programs/water_quality_assessment/2018_integrated_report.html (accessed September 2022).
- United States Department of Agriculture. 2023. Web Soil Survey website: <https://websoilsurvey.sc.egov.usda.gov/App/HomePage.htm> (accessed February 21).
- U.S. Department of Transportation (USDOT). 2017. "Table 4-23: Average Fuel Efficiency of U.S. Light Duty Vehicles." <https://www.bts.gov/content/average-fuel-efficiency-us-light-duty-vehicles> (accessed August 2022).
- United States Fish and Wildlife Service. 2023. Information for Planning and Consultation (IPaC). February 21
- Xerces Society for Invertebrate Conservation, Idaho Department of Fish and Game, Washington Department of Fish and Game, National Fish and Wildlife Foundation, and U.S. Fish and Wildlife Service (Xerces et al.). 2023. Western Monarch Milkweed Mapper. Available at: <https://www.monarchmilkweedmapper.org>

APPENDIX A CALEEMOD OUTPUT SHEETS

This page intentionally left blank

Valley View Park Project Custom Report

Table of Contents

1. Basic Project Information

1.1. Basic Project Information

1.2. Land Use Types

1.3. User-Selected Emission Reduction Measures by Emissions Sector

2. Emissions Summary

2.1. Construction Emissions Compared Against Thresholds

2.2. Construction Emissions by Year, Unmitigated

2.3. Construction Emissions by Year, Mitigated

2.4. Operations Emissions Compared Against Thresholds

2.5. Operations Emissions by Sector, Unmitigated

2.6. Operations Emissions by Sector, Mitigated

3. Construction Emissions Details

3.1. Site Preparation (2025) - Unmitigated

3.2. Site Preparation (2025) - Mitigated

3.3. Grading (2025) - Unmitigated

3.4. Grading (2025) - Mitigated

3.5. Building Construction (2025) - Unmitigated

3.6. Building Construction (2025) - Mitigated

3.7. Paving (2025) - Unmitigated

3.8. Paving (2025) - Mitigated

3.9. Architectural Coating (2025) - Unmitigated

3.10. Architectural Coating (2025) - Mitigated

3.11. Architectural Coating (2026) - Unmitigated

3.12. Architectural Coating (2026) - Mitigated

4. Operations Emissions Details

4.1. Mobile Emissions by Land Use

4.1.1. Unmitigated

4.1.2. Mitigated

4.2. Energy

4.2.1. Electricity Emissions By Land Use - Unmitigated

4.2.2. Electricity Emissions By Land Use - Mitigated

4.2.3. Natural Gas Emissions By Land Use - Unmitigated

4.2.4. Natural Gas Emissions By Land Use - Mitigated

4.3. Area Emissions by Source

4.3.2. Unmitigated

4.3.1. Mitigated

4.4. Water Emissions by Land Use

4.4.2. Unmitigated

4.4.1. Mitigated

4.5. Waste Emissions by Land Use

4.5.2. Unmitigated

4.5.1. Mitigated

4.6. Refrigerant Emissions by Land Use

4.6.1. Unmitigated

4.6.2. Mitigated

4.7. Offroad Emissions By Equipment Type

4.7.1. Unmitigated

4.7.2. Mitigated

4.8. Stationary Emissions By Equipment Type

4.8.1. Unmitigated

4.8.2. Mitigated

4.9. User Defined Emissions By Equipment Type

4.9.1. Unmitigated

4.9.2. Mitigated

4.10. Soil Carbon Accumulation By Vegetation Type

4.10.1. Soil Carbon Accumulation By Vegetation Type - Unmitigated

4.10.2. Above and Belowground Carbon Accumulation by Land Use Type - Unmitigated

4.10.3. Avoided and Sequestered Emissions by Species - Unmitigated

4.10.4. Soil Carbon Accumulation By Vegetation Type - Mitigated

4.10.5. Above and Belowground Carbon Accumulation by Land Use Type - Mitigated

4.10.6. Avoided and Sequestered Emissions by Species - Mitigated

5. Activity Data

5.1. Construction Schedule

5.2. Off-Road Equipment

5.2.1. Unmitigated

5.2.2. Mitigated

5.3. Construction Vehicles

5.3.1. Unmitigated

5.3.2. Mitigated

5.4. Vehicles

5.4.1. Construction Vehicle Control Strategies

5.5. Architectural Coatings

5.6. Dust Mitigation

5.6.1. Construction Earthmoving Activities

5.6.2. Construction Earthmoving Control Strategies

5.7. Construction Paving

5.8. Construction Electricity Consumption and Emissions Factors

5.9. Operational Mobile Sources

5.9.1. Unmitigated

5.9.2. Mitigated

5.10. Operational Area Sources

5.10.1. Hearths

5.10.1.1. Unmitigated

5.10.1.2. Mitigated

5.10.2. Architectural Coatings

5.10.3. Landscape Equipment

5.10.4. Landscape Equipment - Mitigated

5.11. Operational Energy Consumption

5.11.1. Unmitigated

5.11.2. Mitigated

5.12. Operational Water and Wastewater Consumption

5.12.1. Unmitigated

5.12.2. Mitigated

5.13. Operational Waste Generation

5.13.1. Unmitigated

5.13.2. Mitigated

5.14. Operational Refrigeration and Air Conditioning Equipment

5.14.1. Unmitigated

5.14.2. Mitigated

5.15. Operational Off-Road Equipment

5.15.1. Unmitigated

5.15.2. Mitigated

5.16. Stationary Sources

5.16.1. Emergency Generators and Fire Pumps

5.16.2. Process Boilers

5.17. User Defined

5.18. Vegetation

5.18.1. Land Use Change

5.18.1.1. Unmitigated

5.18.1.2. Mitigated

5.18.1. Biomass Cover Type

5.18.1.1. Unmitigated

5.18.1.2. Mitigated

5.18.2. Sequestration

5.18.2.1. Unmitigated

5.18.2.2. Mitigated

8. User Changes to Default Data

1. Basic Project Information

1.1. Basic Project Information

Data Field	Value
Project Name	Valley View Park Project
Lead Agency	—
Land Use Scale	Project/site
Analysis Level for Defaults	County
Windspeed (m/s)	3.30
Precipitation (days)	15.6
Location	37.706549577204, -122.09752539555075
County	Alameda
City	Unincorporated
Air District	Bay Area AQMD
Air Basin	San Francisco Bay Area
TAZ	1416
EDFZ	1
Electric Utility	Pacific Gas & Electric Company
Gas Utility	Pacific Gas & Electric

1.2. Land Use Types

Land Use Subtype	Size	Unit	Lot Acreage	Building Area (sq ft)	Landscape Area (sq ft)	Special Landscape Area (sq ft)	Population	Description
City Park	24.0	Acre	24.0	0.00	0.00	0.00	—	—
Parking Lot	30.0	Space	0.27	0.00	0.00	—	—	—

1.3. User-Selected Emission Reduction Measures by Emissions Sector

Sector	#	Measure Title
Construction	C-11	Limit Vehicle Speeds on Unpaved Roads

2. Emissions Summary

2.1. Construction Emissions Compared Against Thresholds

Criteria Pollutants (lb/day for daily, ton/yr for annual) and GHGs (lb/day for daily, MT/yr for annual)

Un/Mit.	ROG	NOx	CO	SO2	PM10E	PM10D	PM10T	PM2.5E	PM2.5D	PM2.5T	CO2T	CH4	N2O	CO2e
Daily, Summer (Max)	—	—	—	—	—	—	—	—	—	—	—	—	—	—
Unmit.	0.67	20.0	15.3	0.03	0.75	0.00	0.75	0.70	0.00	0.70	2,531	0.10	0.02	2,540
Mit.	0.67	20.0	15.3	0.03	0.75	0.00	0.75	0.70	0.00	0.70	2,531	0.10	0.02	2,540
% Reduced	—	—	—	—	—	—	—	—	—	—	—	—	—	—
Daily, Winter (Max)	—	—	—	—	—	—	—	—	—	—	—	—	—	—
Unmit.	1.40	49.1	36.1	0.06	1.36	7.81	8.93	1.23	3.97	4.99	6,914	0.28	0.09	6,946
Mit.	1.40	49.1	36.1	0.06	1.36	7.81	8.93	1.23	3.97	4.99	6,914	0.28	0.09	6,946
% Reduced	—	—	—	—	—	—	—	—	—	—	—	—	—	—
Average Daily (Max)	—	—	—	—	—	—	—	—	—	—	—	—	—	—
Unmit.	0.50	15.5	11.7	0.02	0.54	0.48	1.02	0.50	0.22	0.73	2,004	0.08	0.02	2,011
Mit.	0.50	15.5	11.7	0.02	0.54	0.48	1.02	0.50	0.22	0.73	2,004	0.08	0.02	2,011
% Reduced	—	—	—	—	—	—	—	—	—	—	—	—	—	—
Annual (Max)	—	—	—	—	—	—	—	—	—	—	—	—	—	—
Unmit.	0.09	2.82	2.13	< 0.005	0.10	0.09	0.19	0.09	0.04	0.13	332	0.01	< 0.005	333

Mit.	0.09	2.82	2.13	< 0.005	0.10	0.09	0.19	0.09	0.04	0.13	332	0.01	< 0.005	333
% Reduced	—	—	—	—	—	—	—	—	—	—	—	—	—	—

2.2. Construction Emissions by Year, Unmitigated

Criteria Pollutants (lb/day for daily, ton/yr for annual) and GHGs (lb/day for daily, MT/yr for annual)

Year	ROG	NOx	CO	SO2	PM10E	PM10D	PM10T	PM2.5E	PM2.5D	PM2.5T	CO2T	CH4	N2O	CO2e
Daily - Summer (Max)	—	—	—	—	—	—	—	—	—	—	—	—	—	—
2025	0.67	20.0	15.3	0.03	0.75	0.00	0.75	0.70	0.00	0.70	2,531	0.10	0.02	2,540
Daily - Winter (Max)	—	—	—	—	—	—	—	—	—	—	—	—	—	—
2025	1.40	49.1	36.1	0.06	1.36	7.81	8.93	1.23	3.97	4.99	6,914	0.28	0.09	6,946
2026	0.05	1.09	0.96	< 0.005	0.07	0.00	0.07	0.06	0.00	0.06	134	0.01	< 0.005	134
Average Daily	—	—	—	—	—	—	—	—	—	—	—	—	—	—
2025	0.50	15.5	11.7	0.02	0.54	0.48	1.02	0.50	0.22	0.73	2,004	0.08	0.02	2,011
2026	< 0.005	< 0.005	< 0.005	< 0.005	< 0.005	0.00	< 0.005	< 0.005	0.00	< 0.005	0.52	< 0.005	< 0.005	0.52
Annual	—	—	—	—	—	—	—	—	—	—	—	—	—	—
2025	0.09	2.82	2.13	< 0.005	0.10	0.09	0.19	0.09	0.04	0.13	332	0.01	< 0.005	333
2026	< 0.005	< 0.005	< 0.005	< 0.005	< 0.005	0.00	< 0.005	< 0.005	0.00	< 0.005	0.09	< 0.005	< 0.005	0.09

2.3. Construction Emissions by Year, Mitigated

Criteria Pollutants (lb/day for daily, ton/yr for annual) and GHGs (lb/day for daily, MT/yr for annual)

Year	ROG	NOx	CO	SO2	PM10E	PM10D	PM10T	PM2.5E	PM2.5D	PM2.5T	CO2T	CH4	N2O	CO2e
Daily - Summer (Max)	—	—	—	—	—	—	—	—	—	—	—	—	—	—

2025	0.67	20.0	15.3	0.03	0.75	0.00	0.75	0.70	0.00	0.70	2,531	0.10	0.02	2,540
Daily - Winter (Max)	—	—	—	—	—	—	—	—	—	—	—	—	—	—
2025	1.40	49.1	36.1	0.06	1.36	7.81	8.93	1.23	3.97	4.99	6,914	0.28	0.09	6,946
2026	0.05	1.09	0.96	< 0.005	0.07	0.00	0.07	0.06	0.00	0.06	134	0.01	< 0.005	134
Average Daily	—	—	—	—	—	—	—	—	—	—	—	—	—	—
2025	0.50	15.5	11.7	0.02	0.54	0.48	1.02	0.50	0.22	0.73	2,004	0.08	0.02	2,011
2026	< 0.005	< 0.005	< 0.005	< 0.005	< 0.005	0.00	< 0.005	< 0.005	0.00	< 0.005	0.52	< 0.005	< 0.005	0.52
Annual	—	—	—	—	—	—	—	—	—	—	—	—	—	—
2025	0.09	2.82	2.13	< 0.005	0.10	0.09	0.19	0.09	0.04	0.13	332	0.01	< 0.005	333
2026	< 0.005	< 0.005	< 0.005	< 0.005	< 0.005	0.00	< 0.005	< 0.005	0.00	< 0.005	0.09	< 0.005	< 0.005	0.09

2.4. Operations Emissions Compared Against Thresholds

Criteria Pollutants (lb/day for daily, ton/yr for annual) and GHGs (lb/day for daily, MT/yr for annual)

Un/Mit.	ROG	NOx	CO	SO2	PM10E	PM10D	PM10T	PM2.5E	PM2.5D	PM2.5T	CO2T	CH4	N2O	CO2e
Daily, Summer (Max)	—	—	—	—	—	—	—	—	—	—	—	—	—	—
Unmit.	0.86	0.68	6.70	0.02	0.01	0.60	0.61	0.01	0.11	0.12	1,729	0.18	0.08	1,762
Daily, Winter (Max)	—	—	—	—	—	—	—	—	—	—	—	—	—	—
Unmit.	0.83	0.79	6.45	0.02	0.01	0.60	0.61	0.01	0.11	0.12	1,632	0.19	0.08	1,662
Average Daily (Max)	—	—	—	—	—	—	—	—	—	—	—	—	—	—
Unmit.	0.81	0.75	6.18	0.02	0.01	0.60	0.61	0.01	0.11	0.12	1,641	0.19	0.08	1,671
Annual (Max)	—	—	—	—	—	—	—	—	—	—	—	—	—	—

Unmit.	0.15	0.14	1.13	< 0.005	< 0.005	0.11	0.11	< 0.005	0.02	0.02	272	0.03	0.01	277
--------	------	------	------	---------	---------	------	------	---------	------	------	-----	------	------	-----

2.5. Operations Emissions by Sector, Unmitigated

Criteria Pollutants (lb/day for daily, ton/yr for annual) and GHGs (lb/day for daily, MT/yr for annual)

Sector	ROG	NOx	CO	SO2	PM10E	PM10D	PM10T	PM2.5E	PM2.5D	PM2.5T	CO2T	CH4	N2O	CO2e
Daily, Summer (Max)	—	—	—	—	—	—	—	—	—	—	—	—	—	—
Mobile	0.86	0.68	6.70	0.02	0.01	0.60	0.61	0.01	0.11	0.12	1,725	0.07	0.07	1,756
Area	< 0.005	0.00	0.00	0.00	0.00	—	0.00	0.00	—	0.00	0.00	0.00	0.00	0.00
Energy	0.00	0.00	0.00	0.00	0.00	—	0.00	0.00	—	0.00	2.88	< 0.005	< 0.005	2.91
Water	—	—	—	—	—	—	—	—	—	—	0.00	0.00	0.00	0.00
Waste	—	—	—	—	—	—	—	—	—	—	1.11	0.11	0.00	3.89
Refrig.	—	—	—	—	—	—	—	—	—	—	—	—	—	0.00
Total	0.86	0.68	6.70	0.02	0.01	0.60	0.61	0.01	0.11	0.12	1,729	0.18	0.08	1,762
Daily, Winter (Max)	—	—	—	—	—	—	—	—	—	—	—	—	—	—
Mobile	0.82	0.79	6.45	0.02	0.01	0.60	0.61	0.01	0.11	0.12	1,628	0.08	0.08	1,655
Area	< 0.005	—	—	—	—	—	—	—	—	—	—	—	—	—
Energy	0.00	0.00	0.00	0.00	0.00	—	0.00	0.00	—	0.00	2.88	< 0.005	< 0.005	2.91
Water	—	—	—	—	—	—	—	—	—	—	0.00	0.00	0.00	0.00
Waste	—	—	—	—	—	—	—	—	—	—	1.11	0.11	0.00	3.89
Refrig.	—	—	—	—	—	—	—	—	—	—	—	—	—	0.00
Total	0.83	0.79	6.45	0.02	0.01	0.60	0.61	0.01	0.11	0.12	1,632	0.19	0.08	1,662
Average Daily	—	—	—	—	—	—	—	—	—	—	—	—	—	—
Mobile	0.81	0.75	6.18	0.02	0.01	0.60	0.61	0.01	0.11	0.12	1,637	0.08	0.08	1,665
Area	< 0.005	0.00	0.00	0.00	0.00	—	0.00	0.00	—	0.00	0.00	0.00	0.00	0.00

Energy	0.00	0.00	0.00	0.00	0.00	—	0.00	0.00	—	0.00	2.88	< 0.005	< 0.005	2.91
Water	—	—	—	—	—	—	—	—	—	—	0.00	0.00	0.00	0.00
Waste	—	—	—	—	—	—	—	—	—	—	1.11	0.11	0.00	3.89
Refrig.	—	—	—	—	—	—	—	—	—	—	—	—	—	0.00
Total	0.81	0.75	6.18	0.02	0.01	0.60	0.61	0.01	0.11	0.12	1,641	0.19	0.08	1,671
Annual	—	—	—	—	—	—	—	—	—	—	—	—	—	—
Mobile	0.15	0.14	1.13	< 0.005	< 0.005	0.11	0.11	< 0.005	0.02	0.02	271	0.01	0.01	276
Area	< 0.005	0.00	0.00	0.00	0.00	—	0.00	0.00	—	0.00	0.00	0.00	0.00	0.00
Energy	0.00	0.00	0.00	0.00	0.00	—	0.00	0.00	—	0.00	0.48	< 0.005	< 0.005	0.48
Water	—	—	—	—	—	—	—	—	—	—	0.00	0.00	0.00	0.00
Waste	—	—	—	—	—	—	—	—	—	—	0.18	0.02	0.00	0.64
Refrig.	—	—	—	—	—	—	—	—	—	—	—	—	—	0.00
Total	0.15	0.14	1.13	< 0.005	< 0.005	0.11	0.11	< 0.005	0.02	0.02	272	0.03	0.01	277

2.6. Operations Emissions by Sector, Mitigated

Criteria Pollutants (lb/day for daily, ton/yr for annual) and GHGs (lb/day for daily, MT/yr for annual)

Sector	ROG	NOx	CO	SO2	PM10E	PM10D	PM10T	PM2.5E	PM2.5D	PM2.5T	CO2T	CH4	N2O	CO2e
Daily, Summer (Max)	—	—	—	—	—	—	—	—	—	—	—	—	—	—
Mobile	0.86	0.68	6.70	0.02	0.01	0.60	0.61	0.01	0.11	0.12	1,725	0.07	0.07	1,756
Area	< 0.005	0.00	0.00	0.00	0.00	—	0.00	0.00	—	0.00	0.00	0.00	0.00	0.00
Energy	0.00	0.00	0.00	0.00	0.00	—	0.00	0.00	—	0.00	2.88	< 0.005	< 0.005	2.91
Water	—	—	—	—	—	—	—	—	—	—	0.00	0.00	0.00	0.00
Waste	—	—	—	—	—	—	—	—	—	—	1.11	0.11	0.00	3.89
Refrig.	—	—	—	—	—	—	—	—	—	—	—	—	—	0.00
Total	0.86	0.68	6.70	0.02	0.01	0.60	0.61	0.01	0.11	0.12	1,729	0.18	0.08	1,762

Daily, Winter (Max)	—	—	—	—	—	—	—	—	—	—	—	—	—	—
Mobile	0.82	0.79	6.45	0.02	0.01	0.60	0.61	0.01	0.11	0.12	1,628	0.08	0.08	1,655
Area	< 0.005	—	—	—	—	—	—	—	—	—	—	—	—	—
Energy	0.00	0.00	0.00	0.00	0.00	—	0.00	0.00	—	0.00	2.88	< 0.005	< 0.005	2.91
Water	—	—	—	—	—	—	—	—	—	—	0.00	0.00	0.00	0.00
Waste	—	—	—	—	—	—	—	—	—	—	1.11	0.11	0.00	3.89
Refrig.	—	—	—	—	—	—	—	—	—	—	—	—	—	0.00
Total	0.83	0.79	6.45	0.02	0.01	0.60	0.61	0.01	0.11	0.12	1,632	0.19	0.08	1,662
Average Daily	—	—	—	—	—	—	—	—	—	—	—	—	—	—
Mobile	0.81	0.75	6.18	0.02	0.01	0.60	0.61	0.01	0.11	0.12	1,637	0.08	0.08	1,665
Area	< 0.005	0.00	0.00	0.00	0.00	—	0.00	0.00	—	0.00	0.00	0.00	0.00	0.00
Energy	0.00	0.00	0.00	0.00	0.00	—	0.00	0.00	—	0.00	2.88	< 0.005	< 0.005	2.91
Water	—	—	—	—	—	—	—	—	—	—	0.00	0.00	0.00	0.00
Waste	—	—	—	—	—	—	—	—	—	—	1.11	0.11	0.00	3.89
Refrig.	—	—	—	—	—	—	—	—	—	—	—	—	—	0.00
Total	0.81	0.75	6.18	0.02	0.01	0.60	0.61	0.01	0.11	0.12	1,641	0.19	0.08	1,671
Annual	—	—	—	—	—	—	—	—	—	—	—	—	—	—
Mobile	0.15	0.14	1.13	< 0.005	< 0.005	0.11	0.11	< 0.005	0.02	0.02	271	0.01	0.01	276
Area	< 0.005	0.00	0.00	0.00	0.00	—	0.00	0.00	—	0.00	0.00	0.00	0.00	0.00
Energy	0.00	0.00	0.00	0.00	0.00	—	0.00	0.00	—	0.00	0.48	< 0.005	< 0.005	0.48
Water	—	—	—	—	—	—	—	—	—	—	0.00	0.00	0.00	0.00
Waste	—	—	—	—	—	—	—	—	—	—	0.18	0.02	0.00	0.64
Refrig.	—	—	—	—	—	—	—	—	—	—	—	—	—	0.00
Total	0.15	0.14	1.13	< 0.005	< 0.005	0.11	0.11	< 0.005	0.02	0.02	272	0.03	0.01	277

3. Construction Emissions Details

3.1. Site Preparation (2025) - Unmitigated

Criteria Pollutants (lb/day for daily, ton/yr for annual) and GHGs (lb/day for daily, MT/yr for annual)

Location	ROG	NOx	CO	SO2	PM10E	PM10D	PM10T	PM2.5E	PM2.5D	PM2.5T	CO2T	CH4	N2O	CO2e
Onsite	—	—	—	—	—	—	—	—	—	—	—	—	—	—
Daily, Summer (Max)	—	—	—	—	—	—	—	—	—	—	—	—	—	—
Daily, Winter (Max)	—	—	—	—	—	—	—	—	—	—	—	—	—	—
Off-Road Equipment	1.07	39.9	28.3	0.05	1.12	—	1.12	1.02	—	1.02	5,295	0.21	0.04	5,314
Dust From Material Movement	—	—	—	—	—	7.67	7.67	—	3.94	3.94	—	—	—	—
Onsite truck	0.00	0.00	0.00	0.00	0.00	0.00	0.00	0.00	0.00	0.00	0.00	0.00	0.00	0.00
Average Daily	—	—	—	—	—	—	—	—	—	—	—	—	—	—
Off-Road Equipment	0.04	1.64	1.16	< 0.005	0.05	—	0.05	0.04	—	0.04	218	0.01	< 0.005	218
Dust From Material Movement	—	—	—	—	—	0.32	0.32	—	0.16	0.16	—	—	—	—
Onsite truck	0.00	0.00	0.00	0.00	0.00	0.00	0.00	0.00	0.00	0.00	0.00	0.00	0.00	0.00
Annual	—	—	—	—	—	—	—	—	—	—	—	—	—	—
Off-Road Equipment	0.01	0.30	0.21	< 0.005	0.01	—	0.01	0.01	—	0.01	36.0	< 0.005	< 0.005	36.2
Dust From Material Movement	—	—	—	—	—	0.06	0.06	—	0.03	0.03	—	—	—	—

Onsite truck	0.00	0.00	0.00	0.00	0.00	0.00	0.00	0.00	0.00	0.00	0.00	0.00	0.00	0.00
Offsite	—	—	—	—	—	—	—	—	—	—	—	—	—	—
Daily, Summer (Max)	—	—	—	—	—	—	—	—	—	—	—	—	—	—
Daily, Winter (Max)	—	—	—	—	—	—	—	—	—	—	—	—	—	—
Worker	0.06	0.05	0.60	0.00	0.00	0.14	0.14	0.00	0.03	0.03	141	< 0.005	0.01	142
Vendor	0.00	0.00	0.00	0.00	0.00	0.00	0.00	0.00	0.00	0.00	0.00	0.00	0.00	0.00
Hauling	0.00	0.00	0.00	0.00	0.00	0.00	0.00	0.00	0.00	0.00	0.00	0.00	0.00	0.00
Average Daily	—	—	—	—	—	—	—	—	—	—	—	—	—	—
Worker	< 0.005	< 0.005	0.02	0.00	0.00	0.01	0.01	0.00	< 0.005	< 0.005	5.82	< 0.005	< 0.005	5.90
Vendor	0.00	0.00	0.00	0.00	0.00	0.00	0.00	0.00	0.00	0.00	0.00	0.00	0.00	0.00
Hauling	0.00	0.00	0.00	0.00	0.00	0.00	0.00	0.00	0.00	0.00	0.00	0.00	0.00	0.00
Annual	—	—	—	—	—	—	—	—	—	—	—	—	—	—
Worker	< 0.005	< 0.005	< 0.005	0.00	0.00	< 0.005	< 0.005	0.00	< 0.005	< 0.005	0.96	< 0.005	< 0.005	0.98
Vendor	0.00	0.00	0.00	0.00	0.00	0.00	0.00	0.00	0.00	0.00	0.00	0.00	0.00	0.00
Hauling	0.00	0.00	0.00	0.00	0.00	0.00	0.00	0.00	0.00	0.00	0.00	0.00	0.00	0.00

3.2. Site Preparation (2025) - Mitigated

Criteria Pollutants (lb/day for daily, ton/yr for annual) and GHGs (lb/day for daily, MT/yr for annual)

Location	ROG	NOx	CO	SO2	PM10E	PM10D	PM10T	PM2.5E	PM2.5D	PM2.5T	CO2T	CH4	N2O	CO2e
Onsite	—	—	—	—	—	—	—	—	—	—	—	—	—	—
Daily, Summer (Max)	—	—	—	—	—	—	—	—	—	—	—	—	—	—

Daily, Winter (Max)	—	—	—	—	—	—	—	—	—	—	—	—	—	—
Off-Road Equipment	1.07	39.9	28.3	0.05	1.12	—	1.12	1.02	—	1.02	5,295	0.21	0.04	5,314
Dust From Material Movement	—	—	—	—	—	7.67	7.67	—	3.94	3.94	—	—	—	—
Onsite truck	0.00	0.00	0.00	0.00	0.00	0.00	0.00	0.00	0.00	0.00	0.00	0.00	0.00	0.00
Average Daily	—	—	—	—	—	—	—	—	—	—	—	—	—	—
Off-Road Equipment	0.04	1.64	1.16	< 0.005	0.05	—	0.05	0.04	—	0.04	218	0.01	< 0.005	218
Dust From Material Movement	—	—	—	—	—	0.32	0.32	—	0.16	0.16	—	—	—	—
Onsite truck	0.00	0.00	0.00	0.00	0.00	0.00	0.00	0.00	0.00	0.00	0.00	0.00	0.00	0.00
Annual	—	—	—	—	—	—	—	—	—	—	—	—	—	—
Off-Road Equipment	0.01	0.30	0.21	< 0.005	0.01	—	0.01	0.01	—	0.01	36.0	< 0.005	< 0.005	36.2
Dust From Material Movement	—	—	—	—	—	0.06	0.06	—	0.03	0.03	—	—	—	—
Onsite truck	0.00	0.00	0.00	0.00	0.00	0.00	0.00	0.00	0.00	0.00	0.00	0.00	0.00	0.00
Offsite	—	—	—	—	—	—	—	—	—	—	—	—	—	—
Daily, Summer (Max)	—	—	—	—	—	—	—	—	—	—	—	—	—	—
Daily, Winter (Max)	—	—	—	—	—	—	—	—	—	—	—	—	—	—
Worker	0.06	0.05	0.60	0.00	0.00	0.14	0.14	0.00	0.03	0.03	141	< 0.005	0.01	142
Vendor	0.00	0.00	0.00	0.00	0.00	0.00	0.00	0.00	0.00	0.00	0.00	0.00	0.00	0.00

Hauling	0.00	0.00	0.00	0.00	0.00	0.00	0.00	0.00	0.00	0.00	0.00	0.00	0.00	0.00
Average Daily	—	—	—	—	—	—	—	—	—	—	—	—	—	—
Worker	< 0.005	< 0.005	0.02	0.00	0.00	0.01	0.01	0.00	< 0.005	< 0.005	5.82	< 0.005	< 0.005	5.90
Vendor	0.00	0.00	0.00	0.00	0.00	0.00	0.00	0.00	0.00	0.00	0.00	0.00	0.00	0.00
Hauling	0.00	0.00	0.00	0.00	0.00	0.00	0.00	0.00	0.00	0.00	0.00	0.00	0.00	0.00
Annual	—	—	—	—	—	—	—	—	—	—	—	—	—	—
Worker	< 0.005	< 0.005	< 0.005	0.00	0.00	< 0.005	< 0.005	0.00	< 0.005	< 0.005	0.96	< 0.005	< 0.005	0.98
Vendor	0.00	0.00	0.00	0.00	0.00	0.00	0.00	0.00	0.00	0.00	0.00	0.00	0.00	0.00
Hauling	0.00	0.00	0.00	0.00	0.00	0.00	0.00	0.00	0.00	0.00	0.00	0.00	0.00	0.00

3.3. Grading (2025) - Unmitigated

Criteria Pollutants (lb/day for daily, ton/yr for annual) and GHGs (lb/day for daily, MT/yr for annual)

Location	ROG	NOx	CO	SO2	PM10E	PM10D	PM10T	PM2.5E	PM2.5D	PM2.5T	CO2T	CH4	N2O	CO2e
Onsite	—	—	—	—	—	—	—	—	—	—	—	—	—	—
Daily, Summer (Max)	—	—	—	—	—	—	—	—	—	—	—	—	—	—
Daily, Winter (Max)	—	—	—	—	—	—	—	—	—	—	—	—	—	—
Off-Road Equipment	1.33	48.8	35.3	0.06	1.36	—	1.36	1.23	—	1.23	6,599	0.27	0.05	6,622
Dust From Material Movement	—	—	—	—	—	3.59	3.59	—	1.43	1.43	—	—	—	—
Onsite truck	0.00	0.00	0.00	0.00	0.00	0.00	0.00	0.00	0.00	0.00	0.00	0.00	0.00	0.00
Average Daily	—	—	—	—	—	—	—	—	—	—	—	—	—	—
Off-Road Equipment	0.05	2.01	1.45	< 0.005	0.06	—	0.06	0.05	—	0.05	271	0.01	< 0.005	272

Dust From Material Movement	—	—	—	—	—	0.15	0.15	—	0.06	0.06	—	—	—	—
Onsite truck	0.00	0.00	0.00	0.00	0.00	0.00	0.00	0.00	0.00	0.00	0.00	0.00	0.00	0.00
Annual	—	—	—	—	—	—	—	—	—	—	—	—	—	—
Off-Road Equipment	0.01	0.37	0.27	< 0.005	0.01	—	0.01	0.01	—	0.01	44.9	< 0.005	< 0.005	45.1
Dust From Material Movement	—	—	—	—	—	0.03	0.03	—	0.01	0.01	—	—	—	—
Onsite truck	0.00	0.00	0.00	0.00	0.00	0.00	0.00	0.00	0.00	0.00	0.00	0.00	0.00	0.00
Offsite	—	—	—	—	—	—	—	—	—	—	—	—	—	—
Daily, Summer (Max)	—	—	—	—	—	—	—	—	—	—	—	—	—	—
Daily, Winter (Max)	—	—	—	—	—	—	—	—	—	—	—	—	—	—
Worker	0.07	0.06	0.68	0.00	0.00	0.17	0.17	0.00	0.04	0.04	161	< 0.005	0.01	163
Vendor	0.00	0.00	0.00	0.00	0.00	0.00	0.00	0.00	0.00	0.00	0.00	0.00	0.00	0.00
Hauling	< 0.005	0.20	0.08	< 0.005	< 0.005	0.04	0.04	< 0.005	0.01	0.01	154	0.01	0.02	162
Average Daily	—	—	—	—	—	—	—	—	—	—	—	—	—	—
Worker	< 0.005	< 0.005	0.03	0.00	0.00	0.01	0.01	0.00	< 0.005	< 0.005	6.65	< 0.005	< 0.005	6.75
Vendor	0.00	0.00	0.00	0.00	0.00	0.00	0.00	0.00	0.00	0.00	0.00	0.00	0.00	0.00
Hauling	< 0.005	0.01	< 0.005	< 0.005	< 0.005	< 0.005	< 0.005	< 0.005	< 0.005	< 0.005	6.34	< 0.005	< 0.005	6.66
Annual	—	—	—	—	—	—	—	—	—	—	—	—	—	—
Worker	< 0.005	< 0.005	< 0.005	0.00	0.00	< 0.005	< 0.005	0.00	< 0.005	< 0.005	1.10	< 0.005	< 0.005	1.12
Vendor	0.00	0.00	0.00	0.00	0.00	0.00	0.00	0.00	0.00	0.00	0.00	0.00	0.00	0.00
Hauling	< 0.005	< 0.005	< 0.005	< 0.005	< 0.005	< 0.005	< 0.005	< 0.005	< 0.005	< 0.005	1.05	< 0.005	< 0.005	1.10

3.4. Grading (2025) - Mitigated

Criteria Pollutants (lb/day for daily, ton/yr for annual) and GHGs (lb/day for daily, MT/yr for annual)

Location	ROG	NOx	CO	SO2	PM10E	PM10D	PM10T	PM2.5E	PM2.5D	PM2.5T	CO2T	CH4	N2O	CO2e
Onsite	—	—	—	—	—	—	—	—	—	—	—	—	—	—
Daily, Summer (Max)	—	—	—	—	—	—	—	—	—	—	—	—	—	—
Daily, Winter (Max)	—	—	—	—	—	—	—	—	—	—	—	—	—	—
Off-Road Equipment	1.33	48.8	35.3	0.06	1.36	—	1.36	1.23	—	1.23	6,599	0.27	0.05	6,622
Dust From Material Movement	—	—	—	—	—	3.59	3.59	—	1.43	1.43	—	—	—	—
Onsite truck	0.00	0.00	0.00	0.00	0.00	0.00	0.00	0.00	0.00	0.00	0.00	0.00	0.00	0.00
Average Daily	—	—	—	—	—	—	—	—	—	—	—	—	—	—
Off-Road Equipment	0.05	2.01	1.45	< 0.005	0.06	—	0.06	0.05	—	0.05	271	0.01	< 0.005	272
Dust From Material Movement	—	—	—	—	—	0.15	0.15	—	0.06	0.06	—	—	—	—
Onsite truck	0.00	0.00	0.00	0.00	0.00	0.00	0.00	0.00	0.00	0.00	0.00	0.00	0.00	0.00
Annual	—	—	—	—	—	—	—	—	—	—	—	—	—	—
Off-Road Equipment	0.01	0.37	0.27	< 0.005	0.01	—	0.01	0.01	—	0.01	44.9	< 0.005	< 0.005	45.1
Dust From Material Movement	—	—	—	—	—	0.03	0.03	—	0.01	0.01	—	—	—	—
Onsite truck	0.00	0.00	0.00	0.00	0.00	0.00	0.00	0.00	0.00	0.00	0.00	0.00	0.00	0.00
Offsite	—	—	—	—	—	—	—	—	—	—	—	—	—	—

Daily, Summer (Max)	—	—	—	—	—	—	—	—	—	—	—	—	—	—
Daily, Winter (Max)	—	—	—	—	—	—	—	—	—	—	—	—	—	—
Worker	0.07	0.06	0.68	0.00	0.00	0.17	0.17	0.00	0.04	0.04	161	< 0.005	0.01	163
Vendor	0.00	0.00	0.00	0.00	0.00	0.00	0.00	0.00	0.00	0.00	0.00	0.00	0.00	0.00
Hauling	< 0.005	0.20	0.08	< 0.005	< 0.005	0.04	0.04	< 0.005	0.01	0.01	154	0.01	0.02	162
Average Daily	—	—	—	—	—	—	—	—	—	—	—	—	—	—
Worker	< 0.005	< 0.005	0.03	0.00	0.00	0.01	0.01	0.00	< 0.005	< 0.005	6.65	< 0.005	< 0.005	6.75
Vendor	0.00	0.00	0.00	0.00	0.00	0.00	0.00	0.00	0.00	0.00	0.00	0.00	0.00	0.00
Hauling	< 0.005	0.01	< 0.005	< 0.005	< 0.005	< 0.005	< 0.005	< 0.005	< 0.005	< 0.005	6.34	< 0.005	< 0.005	6.66
Annual	—	—	—	—	—	—	—	—	—	—	—	—	—	—
Worker	< 0.005	< 0.005	< 0.005	0.00	0.00	< 0.005	< 0.005	0.00	< 0.005	< 0.005	1.10	< 0.005	< 0.005	1.12
Vendor	0.00	0.00	0.00	0.00	0.00	0.00	0.00	0.00	0.00	0.00	0.00	0.00	0.00	0.00
Hauling	< 0.005	< 0.005	< 0.005	< 0.005	< 0.005	< 0.005	< 0.005	< 0.005	< 0.005	< 0.005	1.05	< 0.005	< 0.005	1.10

3.5. Building Construction (2025) - Unmitigated

Criteria Pollutants (lb/day for daily, ton/yr for annual) and GHGs (lb/day for daily, MT/yr for annual)

Location	ROG	NOx	CO	SO2	PM10E	PM10D	PM10T	PM2.5E	PM2.5D	PM2.5T	CO2T	CH4	N2O	CO2e
Onsite	—	—	—	—	—	—	—	—	—	—	—	—	—	—
Daily, Summer (Max)	—	—	—	—	—	—	—	—	—	—	—	—	—	—
Off-Road Equipment	0.62	18.9	14.3	0.02	0.69	—	0.69	0.64	—	0.64	2,398	0.10	0.02	2,406
Onsite truck	0.00	0.00	0.00	0.00	0.00	0.00	0.00	0.00	0.00	0.00	0.00	0.00	0.00	0.00

Daily, Winter (Max)	—	—	—	—	—	—	—	—	—	—	—	—	—	—
Off-Road Equipment	0.62	18.9	14.3	0.02	0.69	—	0.69	0.64	—	0.64	2,398	0.10	0.02	2,406
Onsite truck	0.00	0.00	0.00	0.00	0.00	0.00	0.00	0.00	0.00	0.00	0.00	0.00	0.00	0.00
Average Daily	—	—	—	—	—	—	—	—	—	—	—	—	—	—
Off-Road Equipment	0.37	11.1	8.42	0.01	0.41	—	0.41	0.38	—	0.38	1,412	0.06	0.01	1,417
Onsite truck	0.00	0.00	0.00	0.00	0.00	0.00	0.00	0.00	0.00	0.00	0.00	0.00	0.00	0.00
Annual	—	—	—	—	—	—	—	—	—	—	—	—	—	—
Off-Road Equipment	0.07	2.03	1.54	< 0.005	0.07	—	0.07	0.07	—	0.07	234	0.01	< 0.005	235
Onsite truck	0.00	0.00	0.00	0.00	0.00	0.00	0.00	0.00	0.00	0.00	0.00	0.00	0.00	0.00
Offsite	—	—	—	—	—	—	—	—	—	—	—	—	—	—
Daily, Summer (Max)	—	—	—	—	—	—	—	—	—	—	—	—	—	—
Worker	0.00	0.00	0.00	0.00	0.00	0.00	0.00	0.00	0.00	0.00	0.00	0.00	0.00	0.00
Vendor	0.00	0.00	0.00	0.00	0.00	0.00	0.00	0.00	0.00	0.00	0.00	0.00	0.00	0.00
Hauling	0.00	0.00	0.00	0.00	0.00	0.00	0.00	0.00	0.00	0.00	0.00	0.00	0.00	0.00
Daily, Winter (Max)	—	—	—	—	—	—	—	—	—	—	—	—	—	—
Worker	0.00	0.00	0.00	0.00	0.00	0.00	0.00	0.00	0.00	0.00	0.00	0.00	0.00	0.00
Vendor	0.00	0.00	0.00	0.00	0.00	0.00	0.00	0.00	0.00	0.00	0.00	0.00	0.00	0.00
Hauling	0.00	0.00	0.00	0.00	0.00	0.00	0.00	0.00	0.00	0.00	0.00	0.00	0.00	0.00
Average Daily	—	—	—	—	—	—	—	—	—	—	—	—	—	—
Worker	0.00	0.00	0.00	0.00	0.00	0.00	0.00	0.00	0.00	0.00	0.00	0.00	0.00	0.00
Vendor	0.00	0.00	0.00	0.00	0.00	0.00	0.00	0.00	0.00	0.00	0.00	0.00	0.00	0.00

Hauling	0.00	0.00	0.00	0.00	0.00	0.00	0.00	0.00	0.00	0.00	0.00	0.00	0.00	0.00
Annual	—	—	—	—	—	—	—	—	—	—	—	—	—	—
Worker	0.00	0.00	0.00	0.00	0.00	0.00	0.00	0.00	0.00	0.00	0.00	0.00	0.00	0.00
Vendor	0.00	0.00	0.00	0.00	0.00	0.00	0.00	0.00	0.00	0.00	0.00	0.00	0.00	0.00
Hauling	0.00	0.00	0.00	0.00	0.00	0.00	0.00	0.00	0.00	0.00	0.00	0.00	0.00	0.00

3.6. Building Construction (2025) - Mitigated

Criteria Pollutants (lb/day for daily, ton/yr for annual) and GHGs (lb/day for daily, MT/yr for annual)

Location	ROG	NOx	CO	SO2	PM10E	PM10D	PM10T	PM2.5E	PM2.5D	PM2.5T	CO2T	CH4	N2O	CO2e
Onsite	—	—	—	—	—	—	—	—	—	—	—	—	—	—
Daily, Summer (Max)	—	—	—	—	—	—	—	—	—	—	—	—	—	—
Off-Road Equipment	0.62	18.9	14.3	0.02	0.69	—	0.69	0.64	—	0.64	2,398	0.10	0.02	2,406
Onsite truck	0.00	0.00	0.00	0.00	0.00	0.00	0.00	0.00	0.00	0.00	0.00	0.00	0.00	0.00
Daily, Winter (Max)	—	—	—	—	—	—	—	—	—	—	—	—	—	—
Off-Road Equipment	0.62	18.9	14.3	0.02	0.69	—	0.69	0.64	—	0.64	2,398	0.10	0.02	2,406
Onsite truck	0.00	0.00	0.00	0.00	0.00	0.00	0.00	0.00	0.00	0.00	0.00	0.00	0.00	0.00
Average Daily	—	—	—	—	—	—	—	—	—	—	—	—	—	—
Off-Road Equipment	0.37	11.1	8.42	0.01	0.41	—	0.41	0.38	—	0.38	1,412	0.06	0.01	1,417
Onsite truck	0.00	0.00	0.00	0.00	0.00	0.00	0.00	0.00	0.00	0.00	0.00	0.00	0.00	0.00
Annual	—	—	—	—	—	—	—	—	—	—	—	—	—	—
Off-Road Equipment	0.07	2.03	1.54	< 0.005	0.07	—	0.07	0.07	—	0.07	234	0.01	< 0.005	235

Onsite truck	0.00	0.00	0.00	0.00	0.00	0.00	0.00	0.00	0.00	0.00	0.00	0.00	0.00	0.00
Offsite	—	—	—	—	—	—	—	—	—	—	—	—	—	—
Daily, Summer (Max)	—	—	—	—	—	—	—	—	—	—	—	—	—	—
Worker	0.00	0.00	0.00	0.00	0.00	0.00	0.00	0.00	0.00	0.00	0.00	0.00	0.00	0.00
Vendor	0.00	0.00	0.00	0.00	0.00	0.00	0.00	0.00	0.00	0.00	0.00	0.00	0.00	0.00
Hauling	0.00	0.00	0.00	0.00	0.00	0.00	0.00	0.00	0.00	0.00	0.00	0.00	0.00	0.00
Daily, Winter (Max)	—	—	—	—	—	—	—	—	—	—	—	—	—	—
Worker	0.00	0.00	0.00	0.00	0.00	0.00	0.00	0.00	0.00	0.00	0.00	0.00	0.00	0.00
Vendor	0.00	0.00	0.00	0.00	0.00	0.00	0.00	0.00	0.00	0.00	0.00	0.00	0.00	0.00
Hauling	0.00	0.00	0.00	0.00	0.00	0.00	0.00	0.00	0.00	0.00	0.00	0.00	0.00	0.00
Average Daily	—	—	—	—	—	—	—	—	—	—	—	—	—	—
Worker	0.00	0.00	0.00	0.00	0.00	0.00	0.00	0.00	0.00	0.00	0.00	0.00	0.00	0.00
Vendor	0.00	0.00	0.00	0.00	0.00	0.00	0.00	0.00	0.00	0.00	0.00	0.00	0.00	0.00
Hauling	0.00	0.00	0.00	0.00	0.00	0.00	0.00	0.00	0.00	0.00	0.00	0.00	0.00	0.00
Annual	—	—	—	—	—	—	—	—	—	—	—	—	—	—
Worker	0.00	0.00	0.00	0.00	0.00	0.00	0.00	0.00	0.00	0.00	0.00	0.00	0.00	0.00
Vendor	0.00	0.00	0.00	0.00	0.00	0.00	0.00	0.00	0.00	0.00	0.00	0.00	0.00	0.00
Hauling	0.00	0.00	0.00	0.00	0.00	0.00	0.00	0.00	0.00	0.00	0.00	0.00	0.00	0.00

3.7. Paving (2025) - Unmitigated

Criteria Pollutants (lb/day for daily, ton/yr for annual) and GHGs (lb/day for daily, MT/yr for annual)

Location	ROG	NOx	CO	SO2	PM10E	PM10D	PM10T	PM2.5E	PM2.5D	PM2.5T	CO2T	CH4	N2O	CO2e
Onsite	—	—	—	—	—	—	—	—	—	—	—	—	—	—

Daily, Summer (Max)	—	—	—	—	—	—	—	—	—	—	—	—	—	—
Daily, Winter (Max)	—	—	—	—	—	—	—	—	—	—	—	—	—	—
Off-Road Equipment	0.50	13.3	10.6	0.01	0.58	—	0.58	0.54	—	0.54	1,511	0.06	0.01	1,517
Paving	0.04	—	—	—	—	—	—	—	—	—	—	—	—	—
Onsite truck	0.00	0.00	0.00	0.00	0.00	0.00	0.00	0.00	0.00	0.00	0.00	0.00	0.00	0.00
Average Daily	—	—	—	—	—	—	—	—	—	—	—	—	—	—
Off-Road Equipment	0.01	0.36	0.29	< 0.005	0.02	—	0.02	0.01	—	0.01	41.4	< 0.005	< 0.005	41.6
Paving	< 0.005	—	—	—	—	—	—	—	—	—	—	—	—	—
Onsite truck	0.00	0.00	0.00	0.00	0.00	0.00	0.00	0.00	0.00	0.00	0.00	0.00	0.00	0.00
Annual	—	—	—	—	—	—	—	—	—	—	—	—	—	—
Off-Road Equipment	< 0.005	0.07	0.05	< 0.005	< 0.005	—	< 0.005	< 0.005	—	< 0.005	6.86	< 0.005	< 0.005	6.88
Paving	< 0.005	—	—	—	—	—	—	—	—	—	—	—	—	—
Onsite truck	0.00	0.00	0.00	0.00	0.00	0.00	0.00	0.00	0.00	0.00	0.00	0.00	0.00	0.00
Offsite	—	—	—	—	—	—	—	—	—	—	—	—	—	—
Daily, Summer (Max)	—	—	—	—	—	—	—	—	—	—	—	—	—	—
Daily, Winter (Max)	—	—	—	—	—	—	—	—	—	—	—	—	—	—
Worker	0.05	0.05	0.51	0.00	0.00	0.12	0.12	0.00	0.03	0.03	120	< 0.005	0.01	122
Vendor	0.00	0.00	0.00	0.00	0.00	0.00	0.00	0.00	0.00	0.00	0.00	0.00	0.00	0.00
Hauling	0.00	0.00	0.00	0.00	0.00	0.00	0.00	0.00	0.00	0.00	0.00	0.00	0.00	0.00

Average Daily	—	—	—	—	—	—	—	—	—	—	—	—	—	—
Worker	< 0.005	< 0.005	0.01	0.00	0.00	< 0.005	< 0.005	0.00	< 0.005	< 0.005	3.32	< 0.005	< 0.005	3.37
Vendor	0.00	0.00	0.00	0.00	0.00	0.00	0.00	0.00	0.00	0.00	0.00	0.00	0.00	0.00
Hauling	0.00	0.00	0.00	0.00	0.00	0.00	0.00	0.00	0.00	0.00	0.00	0.00	0.00	0.00
Annual	—	—	—	—	—	—	—	—	—	—	—	—	—	—
Worker	< 0.005	< 0.005	< 0.005	0.00	0.00	< 0.005	< 0.005	0.00	< 0.005	< 0.005	0.55	< 0.005	< 0.005	0.56
Vendor	0.00	0.00	0.00	0.00	0.00	0.00	0.00	0.00	0.00	0.00	0.00	0.00	0.00	0.00
Hauling	0.00	0.00	0.00	0.00	0.00	0.00	0.00	0.00	0.00	0.00	0.00	0.00	0.00	0.00

3.8. Paving (2025) - Mitigated

Criteria Pollutants (lb/day for daily, ton/yr for annual) and GHGs (lb/day for daily, MT/yr for annual)

Location	ROG	NOx	CO	SO2	PM10E	PM10D	PM10T	PM2.5E	PM2.5D	PM2.5T	CO2T	CH4	N2O	CO2e
Onsite	—	—	—	—	—	—	—	—	—	—	—	—	—	—
Daily, Summer (Max)	—	—	—	—	—	—	—	—	—	—	—	—	—	—
Daily, Winter (Max)	—	—	—	—	—	—	—	—	—	—	—	—	—	—
Off-Road Equipment	0.50	13.3	10.6	0.01	0.58	—	0.58	0.54	—	0.54	1,511	0.06	0.01	1,517
Paving	0.04	—	—	—	—	—	—	—	—	—	—	—	—	—
Onsite truck	0.00	0.00	0.00	0.00	0.00	0.00	0.00	0.00	0.00	0.00	0.00	0.00	0.00	0.00
Average Daily	—	—	—	—	—	—	—	—	—	—	—	—	—	—
Off-Road Equipment	0.01	0.36	0.29	< 0.005	0.02	—	0.02	0.01	—	0.01	41.4	< 0.005	< 0.005	41.6
Paving	< 0.005	—	—	—	—	—	—	—	—	—	—	—	—	—
Onsite truck	0.00	0.00	0.00	0.00	0.00	0.00	0.00	0.00	0.00	0.00	0.00	0.00	0.00	0.00

Annual	—	—	—	—	—	—	—	—	—	—	—	—	—	—
Off-Road Equipment	< 0.005	0.07	0.05	< 0.005	< 0.005	—	< 0.005	< 0.005	—	< 0.005	6.86	< 0.005	< 0.005	6.88
Paving	< 0.005	—	—	—	—	—	—	—	—	—	—	—	—	—
Onsite truck	0.00	0.00	0.00	0.00	0.00	0.00	0.00	0.00	0.00	0.00	0.00	0.00	0.00	0.00
Offsite	—	—	—	—	—	—	—	—	—	—	—	—	—	—
Daily, Summer (Max)	—	—	—	—	—	—	—	—	—	—	—	—	—	—
Daily, Winter (Max)	—	—	—	—	—	—	—	—	—	—	—	—	—	—
Worker	0.05	0.05	0.51	0.00	0.00	0.12	0.12	0.00	0.03	0.03	120	< 0.005	0.01	122
Vendor	0.00	0.00	0.00	0.00	0.00	0.00	0.00	0.00	0.00	0.00	0.00	0.00	0.00	0.00
Hauling	0.00	0.00	0.00	0.00	0.00	0.00	0.00	0.00	0.00	0.00	0.00	0.00	0.00	0.00
Average Daily	—	—	—	—	—	—	—	—	—	—	—	—	—	—
Worker	< 0.005	< 0.005	0.01	0.00	0.00	< 0.005	< 0.005	0.00	< 0.005	< 0.005	3.32	< 0.005	< 0.005	3.37
Vendor	0.00	0.00	0.00	0.00	0.00	0.00	0.00	0.00	0.00	0.00	0.00	0.00	0.00	0.00
Hauling	0.00	0.00	0.00	0.00	0.00	0.00	0.00	0.00	0.00	0.00	0.00	0.00	0.00	0.00
Annual	—	—	—	—	—	—	—	—	—	—	—	—	—	—
Worker	< 0.005	< 0.005	< 0.005	0.00	0.00	< 0.005	< 0.005	0.00	< 0.005	< 0.005	0.55	< 0.005	< 0.005	0.56
Vendor	0.00	0.00	0.00	0.00	0.00	0.00	0.00	0.00	0.00	0.00	0.00	0.00	0.00	0.00
Hauling	0.00	0.00	0.00	0.00	0.00	0.00	0.00	0.00	0.00	0.00	0.00	0.00	0.00	0.00

3.9. Architectural Coating (2025) - Unmitigated

Criteria Pollutants (lb/day for daily, ton/yr for annual) and GHGs (lb/day for daily, MT/yr for annual)

Location	ROG	NOx	CO	SO2	PM10E	PM10D	PM10T	PM2.5E	PM2.5D	PM2.5T	CO2T	CH4	N2O	CO2e
Onsite	—	—	—	—	—	—	—	—	—	—	—	—	—	—

Daily, Summer (Max)	—	—	—	—	—	—	—	—	—	—	—	—	—	—
Off-Road Equipment	0.05	1.09	0.96	< 0.005	0.07	—	0.07	0.06	—	0.06	134	0.01	< 0.005	134
Onsite truck	0.00	0.00	0.00	0.00	0.00	0.00	0.00	0.00	0.00	0.00	0.00	0.00	0.00	0.00
Daily, Winter (Max)	—	—	—	—	—	—	—	—	—	—	—	—	—	—
Off-Road Equipment	0.05	1.09	0.96	< 0.005	0.07	—	0.07	0.06	—	0.06	134	0.01	< 0.005	134
Onsite truck	0.00	0.00	0.00	0.00	0.00	0.00	0.00	0.00	0.00	0.00	0.00	0.00	0.00	0.00
Average Daily	—	—	—	—	—	—	—	—	—	—	—	—	—	—
Off-Road Equipment	0.02	0.32	0.28	< 0.005	0.02	—	0.02	0.02	—	0.02	39.2	< 0.005	< 0.005	39.3
Onsite truck	0.00	0.00	0.00	0.00	0.00	0.00	0.00	0.00	0.00	0.00	0.00	0.00	0.00	0.00
Annual	—	—	—	—	—	—	—	—	—	—	—	—	—	—
Off-Road Equipment	< 0.005	0.06	0.05	< 0.005	< 0.005	—	< 0.005	< 0.005	—	< 0.005	6.49	< 0.005	< 0.005	6.51
Onsite truck	0.00	0.00	0.00	0.00	0.00	0.00	0.00	0.00	0.00	0.00	0.00	0.00	0.00	0.00
Offsite	—	—	—	—	—	—	—	—	—	—	—	—	—	—
Daily, Summer (Max)	—	—	—	—	—	—	—	—	—	—	—	—	—	—
Worker	0.00	0.00	0.00	0.00	0.00	0.00	0.00	0.00	0.00	0.00	0.00	0.00	0.00	0.00
Vendor	0.00	0.00	0.00	0.00	0.00	0.00	0.00	0.00	0.00	0.00	0.00	0.00	0.00	0.00
Hauling	0.00	0.00	0.00	0.00	0.00	0.00	0.00	0.00	0.00	0.00	0.00	0.00	0.00	0.00
Daily, Winter (Max)	—	—	—	—	—	—	—	—	—	—	—	—	—	—
Worker	0.00	0.00	0.00	0.00	0.00	0.00	0.00	0.00	0.00	0.00	0.00	0.00	0.00	0.00

Vendor	0.00	0.00	0.00	0.00	0.00	0.00	0.00	0.00	0.00	0.00	0.00	0.00	0.00	0.00
Hauling	0.00	0.00	0.00	0.00	0.00	0.00	0.00	0.00	0.00	0.00	0.00	0.00	0.00	0.00
Average Daily	—	—	—	—	—	—	—	—	—	—	—	—	—	—
Worker	0.00	0.00	0.00	0.00	0.00	0.00	0.00	0.00	0.00	0.00	0.00	0.00	0.00	0.00
Vendor	0.00	0.00	0.00	0.00	0.00	0.00	0.00	0.00	0.00	0.00	0.00	0.00	0.00	0.00
Hauling	0.00	0.00	0.00	0.00	0.00	0.00	0.00	0.00	0.00	0.00	0.00	0.00	0.00	0.00
Annual	—	—	—	—	—	—	—	—	—	—	—	—	—	—
Worker	0.00	0.00	0.00	0.00	0.00	0.00	0.00	0.00	0.00	0.00	0.00	0.00	0.00	0.00
Vendor	0.00	0.00	0.00	0.00	0.00	0.00	0.00	0.00	0.00	0.00	0.00	0.00	0.00	0.00
Hauling	0.00	0.00	0.00	0.00	0.00	0.00	0.00	0.00	0.00	0.00	0.00	0.00	0.00	0.00

3.10. Architectural Coating (2025) - Mitigated

Criteria Pollutants (lb/day for daily, ton/yr for annual) and GHGs (lb/day for daily, MT/yr for annual)

Location	ROG	NOx	CO	SO2	PM10E	PM10D	PM10T	PM2.5E	PM2.5D	PM2.5T	CO2T	CH4	N2O	CO2e
Onsite	—	—	—	—	—	—	—	—	—	—	—	—	—	—
Daily, Summer (Max)	—	—	—	—	—	—	—	—	—	—	—	—	—	—
Off-Road Equipment	0.05	1.09	0.96	< 0.005	0.07	—	0.07	0.06	—	0.06	134	0.01	< 0.005	134
Onsite truck	0.00	0.00	0.00	0.00	0.00	0.00	0.00	0.00	0.00	0.00	0.00	0.00	0.00	0.00
Daily, Winter (Max)	—	—	—	—	—	—	—	—	—	—	—	—	—	—
Off-Road Equipment	0.05	1.09	0.96	< 0.005	0.07	—	0.07	0.06	—	0.06	134	0.01	< 0.005	134
Onsite truck	0.00	0.00	0.00	0.00	0.00	0.00	0.00	0.00	0.00	0.00	0.00	0.00	0.00	0.00
Average Daily	—	—	—	—	—	—	—	—	—	—	—	—	—	—

Off-Road Equipment	0.02	0.32	0.28	< 0.005	0.02	—	0.02	0.02	—	0.02	39.2	< 0.005	< 0.005	39.3
Onsite truck	0.00	0.00	0.00	0.00	0.00	0.00	0.00	0.00	0.00	0.00	0.00	0.00	0.00	0.00
Annual	—	—	—	—	—	—	—	—	—	—	—	—	—	—
Off-Road Equipment	< 0.005	0.06	0.05	< 0.005	< 0.005	—	< 0.005	< 0.005	—	< 0.005	6.49	< 0.005	< 0.005	6.51
Onsite truck	0.00	0.00	0.00	0.00	0.00	0.00	0.00	0.00	0.00	0.00	0.00	0.00	0.00	0.00
Offsite	—	—	—	—	—	—	—	—	—	—	—	—	—	—
Daily, Summer (Max)	—	—	—	—	—	—	—	—	—	—	—	—	—	—
Worker	0.00	0.00	0.00	0.00	0.00	0.00	0.00	0.00	0.00	0.00	0.00	0.00	0.00	0.00
Vendor	0.00	0.00	0.00	0.00	0.00	0.00	0.00	0.00	0.00	0.00	0.00	0.00	0.00	0.00
Hauling	0.00	0.00	0.00	0.00	0.00	0.00	0.00	0.00	0.00	0.00	0.00	0.00	0.00	0.00
Daily, Winter (Max)	—	—	—	—	—	—	—	—	—	—	—	—	—	—
Worker	0.00	0.00	0.00	0.00	0.00	0.00	0.00	0.00	0.00	0.00	0.00	0.00	0.00	0.00
Vendor	0.00	0.00	0.00	0.00	0.00	0.00	0.00	0.00	0.00	0.00	0.00	0.00	0.00	0.00
Hauling	0.00	0.00	0.00	0.00	0.00	0.00	0.00	0.00	0.00	0.00	0.00	0.00	0.00	0.00
Average Daily	—	—	—	—	—	—	—	—	—	—	—	—	—	—
Worker	0.00	0.00	0.00	0.00	0.00	0.00	0.00	0.00	0.00	0.00	0.00	0.00	0.00	0.00
Vendor	0.00	0.00	0.00	0.00	0.00	0.00	0.00	0.00	0.00	0.00	0.00	0.00	0.00	0.00
Hauling	0.00	0.00	0.00	0.00	0.00	0.00	0.00	0.00	0.00	0.00	0.00	0.00	0.00	0.00
Annual	—	—	—	—	—	—	—	—	—	—	—	—	—	—
Worker	0.00	0.00	0.00	0.00	0.00	0.00	0.00	0.00	0.00	0.00	0.00	0.00	0.00	0.00
Vendor	0.00	0.00	0.00	0.00	0.00	0.00	0.00	0.00	0.00	0.00	0.00	0.00	0.00	0.00
Hauling	0.00	0.00	0.00	0.00	0.00	0.00	0.00	0.00	0.00	0.00	0.00	0.00	0.00	0.00

3.11. Architectural Coating (2026) - Unmitigated

Criteria Pollutants (lb/day for daily, ton/yr for annual) and GHGs (lb/day for daily, MT/yr for annual)

Location	ROG	NOx	CO	SO2	PM10E	PM10D	PM10T	PM2.5E	PM2.5D	PM2.5T	CO2T	CH4	N2O	CO2e
Onsite	—	—	—	—	—	—	—	—	—	—	—	—	—	—
Daily, Summer (Max)	—	—	—	—	—	—	—	—	—	—	—	—	—	—
Daily, Winter (Max)	—	—	—	—	—	—	—	—	—	—	—	—	—	—
Off-Road Equipment	0.05	1.09	0.96	< 0.005	0.07	—	0.07	0.06	—	0.06	134	0.01	< 0.005	134
Onsite truck	0.00	0.00	0.00	0.00	0.00	0.00	0.00	0.00	0.00	0.00	0.00	0.00	0.00	0.00
Average Daily	—	—	—	—	—	—	—	—	—	—	—	—	—	—
Off-Road Equipment	< 0.005	< 0.005	< 0.005	< 0.005	< 0.005	—	< 0.005	< 0.005	—	< 0.005	0.52	< 0.005	< 0.005	0.52
Onsite truck	0.00	0.00	0.00	0.00	0.00	0.00	0.00	0.00	0.00	0.00	0.00	0.00	0.00	0.00
Annual	—	—	—	—	—	—	—	—	—	—	—	—	—	—
Off-Road Equipment	< 0.005	< 0.005	< 0.005	< 0.005	< 0.005	—	< 0.005	< 0.005	—	< 0.005	0.09	< 0.005	< 0.005	0.09
Onsite truck	0.00	0.00	0.00	0.00	0.00	0.00	0.00	0.00	0.00	0.00	0.00	0.00	0.00	0.00
Offsite	—	—	—	—	—	—	—	—	—	—	—	—	—	—
Daily, Summer (Max)	—	—	—	—	—	—	—	—	—	—	—	—	—	—
Daily, Winter (Max)	—	—	—	—	—	—	—	—	—	—	—	—	—	—
Worker	0.00	0.00	0.00	0.00	0.00	0.00	0.00	0.00	0.00	0.00	0.00	0.00	0.00	0.00
Vendor	0.00	0.00	0.00	0.00	0.00	0.00	0.00	0.00	0.00	0.00	0.00	0.00	0.00	0.00

Hauling	0.00	0.00	0.00	0.00	0.00	0.00	0.00	0.00	0.00	0.00	0.00	0.00	0.00	0.00
Average Daily	—	—	—	—	—	—	—	—	—	—	—	—	—	—
Worker	0.00	0.00	0.00	0.00	0.00	0.00	0.00	0.00	0.00	0.00	0.00	0.00	0.00	0.00
Vendor	0.00	0.00	0.00	0.00	0.00	0.00	0.00	0.00	0.00	0.00	0.00	0.00	0.00	0.00
Hauling	0.00	0.00	0.00	0.00	0.00	0.00	0.00	0.00	0.00	0.00	0.00	0.00	0.00	0.00
Annual	—	—	—	—	—	—	—	—	—	—	—	—	—	—
Worker	0.00	0.00	0.00	0.00	0.00	0.00	0.00	0.00	0.00	0.00	0.00	0.00	0.00	0.00
Vendor	0.00	0.00	0.00	0.00	0.00	0.00	0.00	0.00	0.00	0.00	0.00	0.00	0.00	0.00
Hauling	0.00	0.00	0.00	0.00	0.00	0.00	0.00	0.00	0.00	0.00	0.00	0.00	0.00	0.00

3.12. Architectural Coating (2026) - Mitigated

Criteria Pollutants (lb/day for daily, ton/yr for annual) and GHGs (lb/day for daily, MT/yr for annual)

Location	ROG	NOx	CO	SO2	PM10E	PM10D	PM10T	PM2.5E	PM2.5D	PM2.5T	CO2T	CH4	N2O	CO2e
Onsite	—	—	—	—	—	—	—	—	—	—	—	—	—	—
Daily, Summer (Max)	—	—	—	—	—	—	—	—	—	—	—	—	—	—
Daily, Winter (Max)	—	—	—	—	—	—	—	—	—	—	—	—	—	—
Off-Road Equipment	0.05	1.09	0.96	< 0.005	0.07	—	0.07	0.06	—	0.06	134	0.01	< 0.005	134
Onsite truck	0.00	0.00	0.00	0.00	0.00	0.00	0.00	0.00	0.00	0.00	0.00	0.00	0.00	0.00
Average Daily	—	—	—	—	—	—	—	—	—	—	—	—	—	—
Off-Road Equipment	< 0.005	< 0.005	< 0.005	< 0.005	< 0.005	—	< 0.005	< 0.005	—	< 0.005	0.52	< 0.005	< 0.005	0.52
Onsite truck	0.00	0.00	0.00	0.00	0.00	0.00	0.00	0.00	0.00	0.00	0.00	0.00	0.00	0.00
Annual	—	—	—	—	—	—	—	—	—	—	—	—	—	—

Off-Road Equipment	< 0.005	< 0.005	< 0.005	< 0.005	< 0.005	—	< 0.005	< 0.005	—	< 0.005	0.09	< 0.005	< 0.005	0.09
Onsite truck	0.00	0.00	0.00	0.00	0.00	0.00	0.00	0.00	0.00	0.00	0.00	0.00	0.00	0.00
Offsite	—	—	—	—	—	—	—	—	—	—	—	—	—	—
Daily, Summer (Max)	—	—	—	—	—	—	—	—	—	—	—	—	—	—
Daily, Winter (Max)	—	—	—	—	—	—	—	—	—	—	—	—	—	—
Worker	0.00	0.00	0.00	0.00	0.00	0.00	0.00	0.00	0.00	0.00	0.00	0.00	0.00	0.00
Vendor	0.00	0.00	0.00	0.00	0.00	0.00	0.00	0.00	0.00	0.00	0.00	0.00	0.00	0.00
Hauling	0.00	0.00	0.00	0.00	0.00	0.00	0.00	0.00	0.00	0.00	0.00	0.00	0.00	0.00
Average Daily	—	—	—	—	—	—	—	—	—	—	—	—	—	—
Worker	0.00	0.00	0.00	0.00	0.00	0.00	0.00	0.00	0.00	0.00	0.00	0.00	0.00	0.00
Vendor	0.00	0.00	0.00	0.00	0.00	0.00	0.00	0.00	0.00	0.00	0.00	0.00	0.00	0.00
Hauling	0.00	0.00	0.00	0.00	0.00	0.00	0.00	0.00	0.00	0.00	0.00	0.00	0.00	0.00
Annual	—	—	—	—	—	—	—	—	—	—	—	—	—	—
Worker	0.00	0.00	0.00	0.00	0.00	0.00	0.00	0.00	0.00	0.00	0.00	0.00	0.00	0.00
Vendor	0.00	0.00	0.00	0.00	0.00	0.00	0.00	0.00	0.00	0.00	0.00	0.00	0.00	0.00
Hauling	0.00	0.00	0.00	0.00	0.00	0.00	0.00	0.00	0.00	0.00	0.00	0.00	0.00	0.00

4. Operations Emissions Details

4.1. Mobile Emissions by Land Use

4.1.1. Unmitigated

Criteria Pollutants (lb/day for daily, ton/yr for annual) and GHGs (lb/day for daily, MT/yr for annual)

Land Use	ROG	NOx	CO	SO2	PM10E	PM10D	PM10T	PM2.5E	PM2.5D	PM2.5T	CO2T	CH4	N2O	CO2e
----------	-----	-----	----	-----	-------	-------	-------	--------	--------	--------	------	-----	-----	------

Daily, Summer (Max)	—	—	—	—	—	—	—	—	—	—	—	—	—	—
City Park	0.86	0.68	6.70	0.02	0.01	0.60	0.61	0.01	0.11	0.12	1,725	0.07	0.07	1,756
Parking Lot	0.00	0.00	0.00	0.00	0.00	0.00	0.00	0.00	0.00	0.00	0.00	0.00	0.00	0.00
Total	0.86	0.68	6.70	0.02	0.01	0.60	0.61	0.01	0.11	0.12	1,725	0.07	0.07	1,756
Daily, Winter (Max)	—	—	—	—	—	—	—	—	—	—	—	—	—	—
City Park	0.82	0.79	6.45	0.02	0.01	0.60	0.61	0.01	0.11	0.12	1,628	0.08	0.08	1,655
Parking Lot	0.00	0.00	0.00	0.00	0.00	0.00	0.00	0.00	0.00	0.00	0.00	0.00	0.00	0.00
Total	0.82	0.79	6.45	0.02	0.01	0.60	0.61	0.01	0.11	0.12	1,628	0.08	0.08	1,655
Annual	—	—	—	—	—	—	—	—	—	—	—	—	—	—
City Park	0.15	0.14	1.13	< 0.005	< 0.005	0.11	0.11	< 0.005	0.02	0.02	271	0.01	0.01	276
Parking Lot	0.00	0.00	0.00	0.00	0.00	0.00	0.00	0.00	0.00	0.00	0.00	0.00	0.00	0.00
Total	0.15	0.14	1.13	< 0.005	< 0.005	0.11	0.11	< 0.005	0.02	0.02	271	0.01	0.01	276

4.1.2. Mitigated

Criteria Pollutants (lb/day for daily, ton/yr for annual) and GHGs (lb/day for daily, MT/yr for annual)

Land Use	ROG	NOx	CO	SO2	PM10E	PM10D	PM10T	PM2.5E	PM2.5D	PM2.5T	CO2T	CH4	N2O	CO2e
Daily, Summer (Max)	—	—	—	—	—	—	—	—	—	—	—	—	—	—
City Park	0.86	0.68	6.70	0.02	0.01	0.60	0.61	0.01	0.11	0.12	1,725	0.07	0.07	1,756
Parking Lot	0.00	0.00	0.00	0.00	0.00	0.00	0.00	0.00	0.00	0.00	0.00	0.00	0.00	0.00
Total	0.86	0.68	6.70	0.02	0.01	0.60	0.61	0.01	0.11	0.12	1,725	0.07	0.07	1,756
Daily, Winter (Max)	—	—	—	—	—	—	—	—	—	—	—	—	—	—
City Park	0.82	0.79	6.45	0.02	0.01	0.60	0.61	0.01	0.11	0.12	1,628	0.08	0.08	1,655

Parking Lot	0.00	0.00	0.00	0.00	0.00	0.00	0.00	0.00	0.00	0.00	0.00	0.00	0.00	0.00
Total	0.82	0.79	6.45	0.02	0.01	0.60	0.61	0.01	0.11	0.12	1,628	0.08	0.08	1,655
Annual	—	—	—	—	—	—	—	—	—	—	—	—	—	—
City Park	0.15	0.14	1.13	< 0.005	< 0.005	0.11	0.11	< 0.005	0.02	0.02	271	0.01	0.01	276
Parking Lot	0.00	0.00	0.00	0.00	0.00	0.00	0.00	0.00	0.00	0.00	0.00	0.00	0.00	0.00
Total	0.15	0.14	1.13	< 0.005	< 0.005	0.11	0.11	< 0.005	0.02	0.02	271	0.01	0.01	276

4.2. Energy

4.2.1. Electricity Emissions By Land Use - Unmitigated

Criteria Pollutants (lb/day for daily, ton/yr for annual) and GHGs (lb/day for daily, MT/yr for annual)

Land Use	ROG	NOx	CO	SO2	PM10E	PM10D	PM10T	PM2.5E	PM2.5D	PM2.5T	CO2T	CH4	N2O	CO2e
Daily, Summer (Max)	—	—	—	—	—	—	—	—	—	—	—	—	—	—
City Park	—	—	—	—	—	—	—	—	—	—	0.00	0.00	0.00	0.00
Parking Lot	—	—	—	—	—	—	—	—	—	—	2.88	< 0.005	< 0.005	2.91
Total	—	—	—	—	—	—	—	—	—	—	2.88	< 0.005	< 0.005	2.91
Daily, Winter (Max)	—	—	—	—	—	—	—	—	—	—	—	—	—	—
City Park	—	—	—	—	—	—	—	—	—	—	0.00	0.00	0.00	0.00
Parking Lot	—	—	—	—	—	—	—	—	—	—	2.88	< 0.005	< 0.005	2.91
Total	—	—	—	—	—	—	—	—	—	—	2.88	< 0.005	< 0.005	2.91
Annual	—	—	—	—	—	—	—	—	—	—	—	—	—	—
City Park	—	—	—	—	—	—	—	—	—	—	0.00	0.00	0.00	0.00
Parking Lot	—	—	—	—	—	—	—	—	—	—	0.48	< 0.005	< 0.005	0.48
Total	—	—	—	—	—	—	—	—	—	—	0.48	< 0.005	< 0.005	0.48

4.2.2. Electricity Emissions By Land Use - Mitigated

Criteria Pollutants (lb/day for daily, ton/yr for annual) and GHGs (lb/day for daily, MT/yr for annual)

Land Use	ROG	NOx	CO	SO2	PM10E	PM10D	PM10T	PM2.5E	PM2.5D	PM2.5T	CO2T	CH4	N2O	CO2e
Daily, Summer (Max)	—	—	—	—	—	—	—	—	—	—	—	—	—	—
City Park	—	—	—	—	—	—	—	—	—	—	0.00	0.00	0.00	0.00
Parking Lot	—	—	—	—	—	—	—	—	—	—	2.88	< 0.005	< 0.005	2.91
Total	—	—	—	—	—	—	—	—	—	—	2.88	< 0.005	< 0.005	2.91
Daily, Winter (Max)	—	—	—	—	—	—	—	—	—	—	—	—	—	—
City Park	—	—	—	—	—	—	—	—	—	—	0.00	0.00	0.00	0.00
Parking Lot	—	—	—	—	—	—	—	—	—	—	2.88	< 0.005	< 0.005	2.91
Total	—	—	—	—	—	—	—	—	—	—	2.88	< 0.005	< 0.005	2.91
Annual	—	—	—	—	—	—	—	—	—	—	—	—	—	—
City Park	—	—	—	—	—	—	—	—	—	—	0.00	0.00	0.00	0.00
Parking Lot	—	—	—	—	—	—	—	—	—	—	0.48	< 0.005	< 0.005	0.48
Total	—	—	—	—	—	—	—	—	—	—	0.48	< 0.005	< 0.005	0.48

4.2.3. Natural Gas Emissions By Land Use - Unmitigated

Criteria Pollutants (lb/day for daily, ton/yr for annual) and GHGs (lb/day for daily, MT/yr for annual)

Land Use	ROG	NOx	CO	SO2	PM10E	PM10D	PM10T	PM2.5E	PM2.5D	PM2.5T	CO2T	CH4	N2O	CO2e
Daily, Summer (Max)	—	—	—	—	—	—	—	—	—	—	—	—	—	—
City Park	0.00	0.00	0.00	0.00	0.00	—	0.00	0.00	—	0.00	0.00	0.00	0.00	0.00
Parking Lot	0.00	0.00	0.00	0.00	0.00	—	0.00	0.00	—	0.00	0.00	0.00	0.00	0.00
Total	0.00	0.00	0.00	0.00	0.00	—	0.00	0.00	—	0.00	0.00	0.00	0.00	0.00

Daily, Winter (Max)	—	—	—	—	—	—	—	—	—	—	—	—	—	—
City Park	0.00	0.00	0.00	0.00	0.00	—	0.00	0.00	—	0.00	0.00	0.00	0.00	0.00
Parking Lot	0.00	0.00	0.00	0.00	0.00	—	0.00	0.00	—	0.00	0.00	0.00	0.00	0.00
Total	0.00	0.00	0.00	0.00	0.00	—	0.00	0.00	—	0.00	0.00	0.00	0.00	0.00
Annual	—	—	—	—	—	—	—	—	—	—	—	—	—	—
City Park	0.00	0.00	0.00	0.00	0.00	—	0.00	0.00	—	0.00	0.00	0.00	0.00	0.00
Parking Lot	0.00	0.00	0.00	0.00	0.00	—	0.00	0.00	—	0.00	0.00	0.00	0.00	0.00
Total	0.00	0.00	0.00	0.00	0.00	—	0.00	0.00	—	0.00	0.00	0.00	0.00	0.00

4.2.4. Natural Gas Emissions By Land Use - Mitigated

Criteria Pollutants (lb/day for daily, ton/yr for annual) and GHGs (lb/day for daily, MT/yr for annual)

Land Use	ROG	NOx	CO	SO2	PM10E	PM10D	PM10T	PM2.5E	PM2.5D	PM2.5T	CO2T	CH4	N2O	CO2e
Daily, Summer (Max)	—	—	—	—	—	—	—	—	—	—	—	—	—	—
City Park	0.00	0.00	0.00	0.00	0.00	—	0.00	0.00	—	0.00	0.00	0.00	0.00	0.00
Parking Lot	0.00	0.00	0.00	0.00	0.00	—	0.00	0.00	—	0.00	0.00	0.00	0.00	0.00
Total	0.00	0.00	0.00	0.00	0.00	—	0.00	0.00	—	0.00	0.00	0.00	0.00	0.00
Daily, Winter (Max)	—	—	—	—	—	—	—	—	—	—	—	—	—	—
City Park	0.00	0.00	0.00	0.00	0.00	—	0.00	0.00	—	0.00	0.00	0.00	0.00	0.00
Parking Lot	0.00	0.00	0.00	0.00	0.00	—	0.00	0.00	—	0.00	0.00	0.00	0.00	0.00
Total	0.00	0.00	0.00	0.00	0.00	—	0.00	0.00	—	0.00	0.00	0.00	0.00	0.00
Annual	—	—	—	—	—	—	—	—	—	—	—	—	—	—
City Park	0.00	0.00	0.00	0.00	0.00	—	0.00	0.00	—	0.00	0.00	0.00	0.00	0.00
Parking Lot	0.00	0.00	0.00	0.00	0.00	—	0.00	0.00	—	0.00	0.00	0.00	0.00	0.00

Total	0.00	0.00	0.00	0.00	0.00	—	0.00	0.00	—	0.00	0.00	0.00	0.00	0.00
-------	------	------	------	------	------	---	------	------	---	------	------	------	------	------

4.3. Area Emissions by Source

4.3.2. Unmitigated

Criteria Pollutants (lb/day for daily, ton/yr for annual) and GHGs (lb/day for daily, MT/yr for annual)

Source	ROG	NOx	CO	SO2	PM10E	PM10D	PM10T	PM2.5E	PM2.5D	PM2.5T	CO2T	CH4	N2O	CO2e
Daily, Summer (Max)	—	—	—	—	—	—	—	—	—	—	—	—	—	—
Consumer Products	< 0.005	—	—	—	—	—	—	—	—	—	—	—	—	—
Landscape Equipment	0.00	0.00	0.00	0.00	0.00	—	0.00	0.00	—	0.00	0.00	0.00	0.00	0.00
Total	< 0.005	0.00	0.00	0.00	0.00	—	0.00	0.00	—	0.00	0.00	0.00	0.00	0.00
Daily, Winter (Max)	—	—	—	—	—	—	—	—	—	—	—	—	—	—
Consumer Products	< 0.005	—	—	—	—	—	—	—	—	—	—	—	—	—
Total	< 0.005	—	—	—	—	—	—	—	—	—	—	—	—	—
Annual	—	—	—	—	—	—	—	—	—	—	—	—	—	—
Consumer Products	< 0.005	—	—	—	—	—	—	—	—	—	—	—	—	—
Landscape Equipment	0.00	0.00	0.00	0.00	0.00	—	0.00	0.00	—	0.00	0.00	0.00	0.00	0.00
Total	< 0.005	0.00	0.00	0.00	0.00	—	0.00	0.00	—	0.00	0.00	0.00	0.00	0.00

4.3.1. Mitigated

Criteria Pollutants (lb/day for daily, ton/yr for annual) and GHGs (lb/day for daily, MT/yr for annual)

Source	ROG	NOx	CO	SO2	PM10E	PM10D	PM10T	PM2.5E	PM2.5D	PM2.5T	CO2T	CH4	N2O	CO2e
--------	-----	-----	----	-----	-------	-------	-------	--------	--------	--------	------	-----	-----	------

Daily, Summer (Max)	—	—	—	—	—	—	—	—	—	—	—	—	—	—
Consumer Products	< 0.005	—	—	—	—	—	—	—	—	—	—	—	—	—
Landscape Equipment	0.00	0.00	0.00	0.00	0.00	—	0.00	0.00	—	0.00	0.00	0.00	0.00	0.00
Total	< 0.005	0.00	0.00	0.00	0.00	—	0.00	0.00	—	0.00	0.00	0.00	0.00	0.00
Daily, Winter (Max)	—	—	—	—	—	—	—	—	—	—	—	—	—	—
Consumer Products	< 0.005	—	—	—	—	—	—	—	—	—	—	—	—	—
Total	< 0.005	—	—	—	—	—	—	—	—	—	—	—	—	—
Annual	—	—	—	—	—	—	—	—	—	—	—	—	—	—
Consumer Products	< 0.005	—	—	—	—	—	—	—	—	—	—	—	—	—
Landscape Equipment	0.00	0.00	0.00	0.00	0.00	—	0.00	0.00	—	0.00	0.00	0.00	0.00	0.00
Total	< 0.005	0.00	0.00	0.00	0.00	—	0.00	0.00	—	0.00	0.00	0.00	0.00	0.00

4.4. Water Emissions by Land Use

4.4.2. Unmitigated

Criteria Pollutants (lb/day for daily, ton/yr for annual) and GHGs (lb/day for daily, MT/yr for annual)

Land Use	ROG	NOx	CO	SO2	PM10E	PM10D	PM10T	PM2.5E	PM2.5D	PM2.5T	CO2T	CH4	N2O	CO2e
Daily, Summer (Max)	—	—	—	—	—	—	—	—	—	—	—	—	—	—
City Park	—	—	—	—	—	—	—	—	—	—	0.00	0.00	0.00	0.00
Parking Lot	—	—	—	—	—	—	—	—	—	—	0.00	0.00	0.00	0.00
Total	—	—	—	—	—	—	—	—	—	—	0.00	0.00	0.00	0.00

Daily, Winter (Max)	—	—	—	—	—	—	—	—	—	—	—	—	—	—
City Park	—	—	—	—	—	—	—	—	—	—	0.00	0.00	0.00	0.00
Parking Lot	—	—	—	—	—	—	—	—	—	—	0.00	0.00	0.00	0.00
Total	—	—	—	—	—	—	—	—	—	—	0.00	0.00	0.00	0.00
Annual	—	—	—	—	—	—	—	—	—	—	—	—	—	—
City Park	—	—	—	—	—	—	—	—	—	—	0.00	0.00	0.00	0.00
Parking Lot	—	—	—	—	—	—	—	—	—	—	0.00	0.00	0.00	0.00
Total	—	—	—	—	—	—	—	—	—	—	0.00	0.00	0.00	0.00

4.4.1. Mitigated

Criteria Pollutants (lb/day for daily, ton/yr for annual) and GHGs (lb/day for daily, MT/yr for annual)

Land Use	ROG	NOx	CO	SO2	PM10E	PM10D	PM10T	PM2.5E	PM2.5D	PM2.5T	CO2T	CH4	N2O	CO2e
Daily, Summer (Max)	—	—	—	—	—	—	—	—	—	—	—	—	—	—
City Park	—	—	—	—	—	—	—	—	—	—	0.00	0.00	0.00	0.00
Parking Lot	—	—	—	—	—	—	—	—	—	—	0.00	0.00	0.00	0.00
Total	—	—	—	—	—	—	—	—	—	—	0.00	0.00	0.00	0.00
Daily, Winter (Max)	—	—	—	—	—	—	—	—	—	—	—	—	—	—
City Park	—	—	—	—	—	—	—	—	—	—	0.00	0.00	0.00	0.00
Parking Lot	—	—	—	—	—	—	—	—	—	—	0.00	0.00	0.00	0.00
Total	—	—	—	—	—	—	—	—	—	—	0.00	0.00	0.00	0.00
Annual	—	—	—	—	—	—	—	—	—	—	—	—	—	—
City Park	—	—	—	—	—	—	—	—	—	—	0.00	0.00	0.00	0.00
Parking Lot	—	—	—	—	—	—	—	—	—	—	0.00	0.00	0.00	0.00

Total	—	—	—	—	—	—	—	—	—	—	0.00	0.00	0.00	0.00
-------	---	---	---	---	---	---	---	---	---	---	------	------	------	------

4.5. Waste Emissions by Land Use

4.5.2. Unmitigated

Criteria Pollutants (lb/day for daily, ton/yr for annual) and GHGs (lb/day for daily, MT/yr for annual)

Land Use	ROG	NOx	CO	SO2	PM10E	PM10D	PM10T	PM2.5E	PM2.5D	PM2.5T	CO2T	CH4	N2O	CO2e
Daily, Summer (Max)	—	—	—	—	—	—	—	—	—	—	—	—	—	—
City Park	—	—	—	—	—	—	—	—	—	—	1.11	0.11	0.00	3.89
Parking Lot	—	—	—	—	—	—	—	—	—	—	0.00	0.00	0.00	0.00
Total	—	—	—	—	—	—	—	—	—	—	1.11	0.11	0.00	3.89
Daily, Winter (Max)	—	—	—	—	—	—	—	—	—	—	—	—	—	—
City Park	—	—	—	—	—	—	—	—	—	—	1.11	0.11	0.00	3.89
Parking Lot	—	—	—	—	—	—	—	—	—	—	0.00	0.00	0.00	0.00
Total	—	—	—	—	—	—	—	—	—	—	1.11	0.11	0.00	3.89
Annual	—	—	—	—	—	—	—	—	—	—	—	—	—	—
City Park	—	—	—	—	—	—	—	—	—	—	0.18	0.02	0.00	0.64
Parking Lot	—	—	—	—	—	—	—	—	—	—	0.00	0.00	0.00	0.00
Total	—	—	—	—	—	—	—	—	—	—	0.18	0.02	0.00	0.64

4.5.1. Mitigated

Criteria Pollutants (lb/day for daily, ton/yr for annual) and GHGs (lb/day for daily, MT/yr for annual)

Land Use	ROG	NOx	CO	SO2	PM10E	PM10D	PM10T	PM2.5E	PM2.5D	PM2.5T	CO2T	CH4	N2O	CO2e
----------	-----	-----	----	-----	-------	-------	-------	--------	--------	--------	------	-----	-----	------

Daily, Summer (Max)	—	—	—	—	—	—	—	—	—	—	—	—	—	—
City Park	—	—	—	—	—	—	—	—	—	—	1.11	0.11	0.00	3.89
Parking Lot	—	—	—	—	—	—	—	—	—	—	0.00	0.00	0.00	0.00
Total	—	—	—	—	—	—	—	—	—	—	1.11	0.11	0.00	3.89
Daily, Winter (Max)	—	—	—	—	—	—	—	—	—	—	—	—	—	—
City Park	—	—	—	—	—	—	—	—	—	—	1.11	0.11	0.00	3.89
Parking Lot	—	—	—	—	—	—	—	—	—	—	0.00	0.00	0.00	0.00
Total	—	—	—	—	—	—	—	—	—	—	1.11	0.11	0.00	3.89
Annual	—	—	—	—	—	—	—	—	—	—	—	—	—	—
City Park	—	—	—	—	—	—	—	—	—	—	0.18	0.02	0.00	0.64
Parking Lot	—	—	—	—	—	—	—	—	—	—	0.00	0.00	0.00	0.00
Total	—	—	—	—	—	—	—	—	—	—	0.18	0.02	0.00	0.64

4.6. Refrigerant Emissions by Land Use

4.6.1. Unmitigated

Criteria Pollutants (lb/day for daily, ton/yr for annual) and GHGs (lb/day for daily, MT/yr for annual)

Land Use	ROG	NOx	CO	SO2	PM10E	PM10D	PM10T	PM2.5E	PM2.5D	PM2.5T	CO2T	CH4	N2O	CO2e
Daily, Summer (Max)	—	—	—	—	—	—	—	—	—	—	—	—	—	—
City Park	—	—	—	—	—	—	—	—	—	—	—	—	—	0.00
Total	—	—	—	—	—	—	—	—	—	—	—	—	—	0.00
Daily, Winter (Max)	—	—	—	—	—	—	—	—	—	—	—	—	—	—

City Park	—	—	—	—	—	—	—	—	—	—	—	—	—	0.00
Total	—	—	—	—	—	—	—	—	—	—	—	—	—	0.00
Annual	—	—	—	—	—	—	—	—	—	—	—	—	—	—
City Park	—	—	—	—	—	—	—	—	—	—	—	—	—	0.00
Total	—	—	—	—	—	—	—	—	—	—	—	—	—	0.00

4.6.2. Mitigated

Criteria Pollutants (lb/day for daily, ton/yr for annual) and GHGs (lb/day for daily, MT/yr for annual)

Land Use	ROG	NOx	CO	SO2	PM10E	PM10D	PM10T	PM2.5E	PM2.5D	PM2.5T	CO2T	CH4	N2O	CO2e
Daily, Summer (Max)	—	—	—	—	—	—	—	—	—	—	—	—	—	—
City Park	—	—	—	—	—	—	—	—	—	—	—	—	—	0.00
Total	—	—	—	—	—	—	—	—	—	—	—	—	—	0.00
Daily, Winter (Max)	—	—	—	—	—	—	—	—	—	—	—	—	—	—
City Park	—	—	—	—	—	—	—	—	—	—	—	—	—	0.00
Total	—	—	—	—	—	—	—	—	—	—	—	—	—	0.00
Annual	—	—	—	—	—	—	—	—	—	—	—	—	—	—
City Park	—	—	—	—	—	—	—	—	—	—	—	—	—	0.00
Total	—	—	—	—	—	—	—	—	—	—	—	—	—	0.00

4.7. Offroad Emissions By Equipment Type

4.7.1. Unmitigated

Criteria Pollutants (lb/day for daily, ton/yr for annual) and GHGs (lb/day for daily, MT/yr for annual)

Equipment Type	ROG	NOx	CO	SO2	PM10E	PM10D	PM10T	PM2.5E	PM2.5D	PM2.5T	CO2T	CH4	N2O	CO2e
----------------	-----	-----	----	-----	-------	-------	-------	--------	--------	--------	------	-----	-----	------

Daily, Summer (Max)	—	—	—	—	—	—	—	—	—	—	—	—	—	—
Total	—	—	—	—	—	—	—	—	—	—	—	—	—	—
Daily, Winter (Max)	—	—	—	—	—	—	—	—	—	—	—	—	—	—
Total	—	—	—	—	—	—	—	—	—	—	—	—	—	—
Annual	—	—	—	—	—	—	—	—	—	—	—	—	—	—
Total	—	—	—	—	—	—	—	—	—	—	—	—	—	—

4.7.2. Mitigated

Criteria Pollutants (lb/day for daily, ton/yr for annual) and GHGs (lb/day for daily, MT/yr for annual)

Equipment Type	ROG	NOx	CO	SO2	PM10E	PM10D	PM10T	PM2.5E	PM2.5D	PM2.5T	CO2T	CH4	N2O	CO2e
Daily, Summer (Max)	—	—	—	—	—	—	—	—	—	—	—	—	—	—
Total	—	—	—	—	—	—	—	—	—	—	—	—	—	—
Daily, Winter (Max)	—	—	—	—	—	—	—	—	—	—	—	—	—	—
Total	—	—	—	—	—	—	—	—	—	—	—	—	—	—
Annual	—	—	—	—	—	—	—	—	—	—	—	—	—	—
Total	—	—	—	—	—	—	—	—	—	—	—	—	—	—

4.8. Stationary Emissions By Equipment Type

4.8.1. Unmitigated

Criteria Pollutants (lb/day for daily, ton/yr for annual) and GHGs (lb/day for daily, MT/yr for annual)

Equipment Type	ROG	NOx	CO	SO2	PM10E	PM10D	PM10T	PM2.5E	PM2.5D	PM2.5T	CO2T	CH4	N2O	CO2e
Daily, Summer (Max)	—	—	—	—	—	—	—	—	—	—	—	—	—	—
Total	—	—	—	—	—	—	—	—	—	—	—	—	—	—
Daily, Winter (Max)	—	—	—	—	—	—	—	—	—	—	—	—	—	—
Total	—	—	—	—	—	—	—	—	—	—	—	—	—	—
Annual	—	—	—	—	—	—	—	—	—	—	—	—	—	—
Total	—	—	—	—	—	—	—	—	—	—	—	—	—	—

4.8.2. Mitigated

Criteria Pollutants (lb/day for daily, ton/yr for annual) and GHGs (lb/day for daily, MT/yr for annual)

Equipment Type	ROG	NOx	CO	SO2	PM10E	PM10D	PM10T	PM2.5E	PM2.5D	PM2.5T	CO2T	CH4	N2O	CO2e
Daily, Summer (Max)	—	—	—	—	—	—	—	—	—	—	—	—	—	—
Total	—	—	—	—	—	—	—	—	—	—	—	—	—	—
Daily, Winter (Max)	—	—	—	—	—	—	—	—	—	—	—	—	—	—
Total	—	—	—	—	—	—	—	—	—	—	—	—	—	—
Annual	—	—	—	—	—	—	—	—	—	—	—	—	—	—
Total	—	—	—	—	—	—	—	—	—	—	—	—	—	—

4.9. User Defined Emissions By Equipment Type

4.9.1. Unmitigated

Criteria Pollutants (lb/day for daily, ton/yr for annual) and GHGs (lb/day for daily, MT/yr for annual)

Equipment Type	ROG	NOx	CO	SO2	PM10E	PM10D	PM10T	PM2.5E	PM2.5D	PM2.5T	CO2T	CH4	N2O	CO2e
Daily, Summer (Max)	—	—	—	—	—	—	—	—	—	—	—	—	—	—
Total	—	—	—	—	—	—	—	—	—	—	—	—	—	—
Daily, Winter (Max)	—	—	—	—	—	—	—	—	—	—	—	—	—	—
Total	—	—	—	—	—	—	—	—	—	—	—	—	—	—
Annual	—	—	—	—	—	—	—	—	—	—	—	—	—	—
Total	—	—	—	—	—	—	—	—	—	—	—	—	—	—

4.9.2. Mitigated

Criteria Pollutants (lb/day for daily, ton/yr for annual) and GHGs (lb/day for daily, MT/yr for annual)

Equipment Type	ROG	NOx	CO	SO2	PM10E	PM10D	PM10T	PM2.5E	PM2.5D	PM2.5T	CO2T	CH4	N2O	CO2e
Daily, Summer (Max)	—	—	—	—	—	—	—	—	—	—	—	—	—	—
Total	—	—	—	—	—	—	—	—	—	—	—	—	—	—
Daily, Winter (Max)	—	—	—	—	—	—	—	—	—	—	—	—	—	—
Total	—	—	—	—	—	—	—	—	—	—	—	—	—	—
Annual	—	—	—	—	—	—	—	—	—	—	—	—	—	—
Total	—	—	—	—	—	—	—	—	—	—	—	—	—	—

4.10. Soil Carbon Accumulation By Vegetation Type

4.10.1. Soil Carbon Accumulation By Vegetation Type - Unmitigated

Criteria Pollutants (lb/day for daily, ton/yr for annual) and GHGs (lb/day for daily, MT/yr for annual)

Vegetation	ROG	NOx	CO	SO2	PM10E	PM10D	PM10T	PM2.5E	PM2.5D	PM2.5T	CO2T	CH4	N2O	CO2e
Daily, Summer (Max)	—	—	—	—	—	—	—	—	—	—	—	—	—	—
Total	—	—	—	—	—	—	—	—	—	—	—	—	—	—
Daily, Winter (Max)	—	—	—	—	—	—	—	—	—	—	—	—	—	—
Total	—	—	—	—	—	—	—	—	—	—	—	—	—	—
Annual	—	—	—	—	—	—	—	—	—	—	—	—	—	—
Total	—	—	—	—	—	—	—	—	—	—	—	—	—	—

4.10.2. Above and Belowground Carbon Accumulation by Land Use Type - Unmitigated

Criteria Pollutants (lb/day for daily, ton/yr for annual) and GHGs (lb/day for daily, MT/yr for annual)

Land Use	ROG	NOx	CO	SO2	PM10E	PM10D	PM10T	PM2.5E	PM2.5D	PM2.5T	CO2T	CH4	N2O	CO2e
Daily, Summer (Max)	—	—	—	—	—	—	—	—	—	—	—	—	—	—
Total	—	—	—	—	—	—	—	—	—	—	—	—	—	—
Daily, Winter (Max)	—	—	—	—	—	—	—	—	—	—	—	—	—	—
Total	—	—	—	—	—	—	—	—	—	—	—	—	—	—
Annual	—	—	—	—	—	—	—	—	—	—	—	—	—	—
Total	—	—	—	—	—	—	—	—	—	—	—	—	—	—

4.10.3. Avoided and Sequestered Emissions by Species - Unmitigated

Criteria Pollutants (lb/day for daily, ton/yr for annual) and GHGs (lb/day for daily, MT/yr for annual)

Species	ROG	NOx	CO	SO2	PM10E	PM10D	PM10T	PM2.5E	PM2.5D	PM2.5T	CO2T	CH4	N2O	CO2e
Daily, Summer (Max)	—	—	—	—	—	—	—	—	—	—	—	—	—	—
Avoided	—	—	—	—	—	—	—	—	—	—	—	—	—	—
Subtotal	—	—	—	—	—	—	—	—	—	—	—	—	—	—
Sequestered	—	—	—	—	—	—	—	—	—	—	—	—	—	—
Subtotal	—	—	—	—	—	—	—	—	—	—	—	—	—	—
Removed	—	—	—	—	—	—	—	—	—	—	—	—	—	—
Subtotal	—	—	—	—	—	—	—	—	—	—	—	—	—	—
—	—	—	—	—	—	—	—	—	—	—	—	—	—	—
Daily, Winter (Max)	—	—	—	—	—	—	—	—	—	—	—	—	—	—
Avoided	—	—	—	—	—	—	—	—	—	—	—	—	—	—
Subtotal	—	—	—	—	—	—	—	—	—	—	—	—	—	—
Sequestered	—	—	—	—	—	—	—	—	—	—	—	—	—	—
Subtotal	—	—	—	—	—	—	—	—	—	—	—	—	—	—
Removed	—	—	—	—	—	—	—	—	—	—	—	—	—	—
Subtotal	—	—	—	—	—	—	—	—	—	—	—	—	—	—
—	—	—	—	—	—	—	—	—	—	—	—	—	—	—
Annual	—	—	—	—	—	—	—	—	—	—	—	—	—	—
Avoided	—	—	—	—	—	—	—	—	—	—	—	—	—	—
Subtotal	—	—	—	—	—	—	—	—	—	—	—	—	—	—
Sequestered	—	—	—	—	—	—	—	—	—	—	—	—	—	—
Subtotal	—	—	—	—	—	—	—	—	—	—	—	—	—	—
Removed	—	—	—	—	—	—	—	—	—	—	—	—	—	—

Subtotal	—	—	—	—	—	—	—	—	—	—	—	—	—	—
—	—	—	—	—	—	—	—	—	—	—	—	—	—	—

4.10.4. Soil Carbon Accumulation By Vegetation Type - Mitigated

Criteria Pollutants (lb/day for daily, ton/yr for annual) and GHGs (lb/day for daily, MT/yr for annual)

Vegetation	ROG	NOx	CO	SO2	PM10E	PM10D	PM10T	PM2.5E	PM2.5D	PM2.5T	CO2T	CH4	N2O	CO2e
Daily, Summer (Max)	—	—	—	—	—	—	—	—	—	—	—	—	—	—
Total	—	—	—	—	—	—	—	—	—	—	—	—	—	—
Daily, Winter (Max)	—	—	—	—	—	—	—	—	—	—	—	—	—	—
Total	—	—	—	—	—	—	—	—	—	—	—	—	—	—
Annual	—	—	—	—	—	—	—	—	—	—	—	—	—	—
Total	—	—	—	—	—	—	—	—	—	—	—	—	—	—

4.10.5. Above and Belowground Carbon Accumulation by Land Use Type - Mitigated

Criteria Pollutants (lb/day for daily, ton/yr for annual) and GHGs (lb/day for daily, MT/yr for annual)

Land Use	ROG	NOx	CO	SO2	PM10E	PM10D	PM10T	PM2.5E	PM2.5D	PM2.5T	CO2T	CH4	N2O	CO2e
Daily, Summer (Max)	—	—	—	—	—	—	—	—	—	—	—	—	—	—
Total	—	—	—	—	—	—	—	—	—	—	—	—	—	—
Daily, Winter (Max)	—	—	—	—	—	—	—	—	—	—	—	—	—	—
Total	—	—	—	—	—	—	—	—	—	—	—	—	—	—
Annual	—	—	—	—	—	—	—	—	—	—	—	—	—	—
Total	—	—	—	—	—	—	—	—	—	—	—	—	—	—

4.10.6. Avoided and Sequestered Emissions by Species - Mitigated

Criteria Pollutants (lb/day for daily, ton/yr for annual) and GHGs (lb/day for daily, MT/yr for annual)

Species	ROG	NOx	CO	SO2	PM10E	PM10D	PM10T	PM2.5E	PM2.5D	PM2.5T	CO2T	CH4	N2O	CO2e
Daily, Summer (Max)	—	—	—	—	—	—	—	—	—	—	—	—	—	—
Avoided	—	—	—	—	—	—	—	—	—	—	—	—	—	—
Subtotal	—	—	—	—	—	—	—	—	—	—	—	—	—	—
Sequestered	—	—	—	—	—	—	—	—	—	—	—	—	—	—
Subtotal	—	—	—	—	—	—	—	—	—	—	—	—	—	—
Removed	—	—	—	—	—	—	—	—	—	—	—	—	—	—
Subtotal	—	—	—	—	—	—	—	—	—	—	—	—	—	—
—	—	—	—	—	—	—	—	—	—	—	—	—	—	—
Daily, Winter (Max)	—	—	—	—	—	—	—	—	—	—	—	—	—	—
Avoided	—	—	—	—	—	—	—	—	—	—	—	—	—	—
Subtotal	—	—	—	—	—	—	—	—	—	—	—	—	—	—
Sequestered	—	—	—	—	—	—	—	—	—	—	—	—	—	—
Subtotal	—	—	—	—	—	—	—	—	—	—	—	—	—	—
Removed	—	—	—	—	—	—	—	—	—	—	—	—	—	—
Subtotal	—	—	—	—	—	—	—	—	—	—	—	—	—	—
—	—	—	—	—	—	—	—	—	—	—	—	—	—	—
Annual	—	—	—	—	—	—	—	—	—	—	—	—	—	—
Avoided	—	—	—	—	—	—	—	—	—	—	—	—	—	—
Subtotal	—	—	—	—	—	—	—	—	—	—	—	—	—	—
Sequestered	—	—	—	—	—	—	—	—	—	—	—	—	—	—

Subtotal	—	—	—	—	—	—	—	—	—	—	—	—	—	—
Removed	—	—	—	—	—	—	—	—	—	—	—	—	—	—
Subtotal	—	—	—	—	—	—	—	—	—	—	—	—	—	—
—	—	—	—	—	—	—	—	—	—	—	—	—	—	—

5. Activity Data

5.1. Construction Schedule

Phase Name	Phase Type	Start Date	End Date	Days Per Week	Work Days per Phase	Phase Description
Site Preparation	Site Preparation	1/6/2025	1/24/2025	5.00	15.0	—
Grading	Grading	1/27/2025	2/14/2025	5.00	15.0	—
Building Construction	Building Construction	2/17/2025	12/12/2025	5.00	215	—
Paving	Paving	12/15/2025	12/26/2025	5.00	10.0	—
Architectural Coating	Architectural Coating	8/4/2025	1/2/2026	5.00	110	—

5.2. Off-Road Equipment

5.2.1. Unmitigated

Phase Name	Equipment Type	Fuel Type	Engine Tier	Number per Day	Hours Per Day	Horsepower	Load Factor
Site Preparation	Rubber Tired Dozers	Diesel	Tier 2	3.00	8.00	367	0.40
Site Preparation	Tractors/Loaders/Backhoes	Diesel	Tier 2	4.00	8.00	84.0	0.37
Grading	Excavators	Diesel	Tier 2	2.00	8.00	36.0	0.38
Grading	Graders	Diesel	Tier 2	1.00	8.00	148	0.41
Grading	Rubber Tired Dozers	Diesel	Tier 2	1.00	8.00	367	0.40
Grading	Scrapers	Diesel	Tier 2	2.00	8.00	423	0.48

Grading	Tractors/Loaders/Backhoes	Diesel	Tier 2	2.00	8.00	84.0	0.37
Building Construction	Cranes	Diesel	Tier 2	1.00	7.00	367	0.29
Building Construction	Forklifts	Diesel	Tier 2	3.00	8.00	82.0	0.20
Building Construction	Generator Sets	Diesel	Tier 2	1.00	8.00	14.0	0.74
Building Construction	Tractors/Loaders/Backhoes	Diesel	Tier 2	3.00	7.00	84.0	0.37
Building Construction	Welders	Diesel	Tier 2	1.00	8.00	46.0	0.45
Paving	Pavers	Diesel	Tier 2	2.00	8.00	81.0	0.42
Paving	Paving Equipment	Diesel	Tier 2	2.00	8.00	89.0	0.36
Paving	Rollers	Diesel	Tier 2	2.00	8.00	36.0	0.38
Architectural Coating	Air Compressors	Diesel	Tier 2	1.00	6.00	37.0	0.48

5.2.2. Mitigated

Phase Name	Equipment Type	Fuel Type	Engine Tier	Number per Day	Hours Per Day	Horsepower	Load Factor
Site Preparation	Rubber Tired Dozers	Diesel	Tier 2	3.00	8.00	367	0.40
Site Preparation	Tractors/Loaders/Backhoes	Diesel	Tier 2	4.00	8.00	84.0	0.37
Grading	Excavators	Diesel	Tier 2	2.00	8.00	36.0	0.38
Grading	Graders	Diesel	Tier 2	1.00	8.00	148	0.41
Grading	Rubber Tired Dozers	Diesel	Tier 2	1.00	8.00	367	0.40
Grading	Scrapers	Diesel	Tier 2	2.00	8.00	423	0.48
Grading	Tractors/Loaders/Backhoes	Diesel	Tier 2	2.00	8.00	84.0	0.37
Building Construction	Cranes	Diesel	Tier 2	1.00	7.00	367	0.29
Building Construction	Forklifts	Diesel	Tier 2	3.00	8.00	82.0	0.20
Building Construction	Generator Sets	Diesel	Tier 2	1.00	8.00	14.0	0.74
Building Construction	Tractors/Loaders/Backhoes	Diesel	Tier 2	3.00	7.00	84.0	0.37

Building Construction	Welders	Diesel	Tier 2	1.00	8.00	46.0	0.45
Paving	Pavers	Diesel	Tier 2	2.00	8.00	81.0	0.42
Paving	Paving Equipment	Diesel	Tier 2	2.00	8.00	89.0	0.36
Paving	Rollers	Diesel	Tier 2	2.00	8.00	36.0	0.38
Architectural Coating	Air Compressors	Diesel	Tier 2	1.00	6.00	37.0	0.48

5.3. Construction Vehicles

5.3.1. Unmitigated

Phase Name	Trip Type	One-Way Trips per Day	Miles per Trip	Vehicle Mix
Site Preparation	—	—	—	—
Site Preparation	Worker	17.5	11.7	LDA,LDT1,LDT2
Site Preparation	Vendor	—	8.40	HHDT,MHDT
Site Preparation	Hauling	0.00	20.0	HHDT
Site Preparation	Onsite truck	—	—	HHDT
Grading	—	—	—	—
Grading	Worker	20.0	11.7	LDA,LDT1,LDT2
Grading	Vendor	—	8.40	HHDT,MHDT
Grading	Hauling	2.20	20.0	HHDT
Grading	Onsite truck	—	—	HHDT
Building Construction	—	—	—	—
Building Construction	Worker	0.00	11.7	LDA,LDT1,LDT2
Building Construction	Vendor	0.00	8.40	HHDT,MHDT
Building Construction	Hauling	0.00	20.0	HHDT
Building Construction	Onsite truck	—	—	HHDT
Paving	—	—	—	—
Paving	Worker	15.0	11.7	LDA,LDT1,LDT2

Paving	Vendor	—	8.40	HHDT,MHDT
Paving	Hauling	0.00	20.0	HHDT
Paving	Onsite truck	—	—	HHDT
Architectural Coating	—	—	—	—
Architectural Coating	Worker	0.00	11.7	LDA,LDT1,LDT2
Architectural Coating	Vendor	—	8.40	HHDT,MHDT
Architectural Coating	Hauling	0.00	20.0	HHDT
Architectural Coating	Onsite truck	—	—	HHDT

5.3.2. Mitigated

Phase Name	Trip Type	One-Way Trips per Day	Miles per Trip	Vehicle Mix
Site Preparation	—	—	—	—
Site Preparation	Worker	17.5	11.7	LDA,LDT1,LDT2
Site Preparation	Vendor	—	8.40	HHDT,MHDT
Site Preparation	Hauling	0.00	20.0	HHDT
Site Preparation	Onsite truck	—	—	HHDT
Grading	—	—	—	—
Grading	Worker	20.0	11.7	LDA,LDT1,LDT2
Grading	Vendor	—	8.40	HHDT,MHDT
Grading	Hauling	2.20	20.0	HHDT
Grading	Onsite truck	—	—	HHDT
Building Construction	—	—	—	—
Building Construction	Worker	0.00	11.7	LDA,LDT1,LDT2
Building Construction	Vendor	0.00	8.40	HHDT,MHDT
Building Construction	Hauling	0.00	20.0	HHDT
Building Construction	Onsite truck	—	—	HHDT
Paving	—	—	—	—

Paving	Worker	15.0	11.7	LDA,LDT1,LDT2
Paving	Vendor	—	8.40	HHDT,MHDT
Paving	Hauling	0.00	20.0	HHDT
Paving	Onsite truck	—	—	HHDT
Architectural Coating	—	—	—	—
Architectural Coating	Worker	0.00	11.7	LDA,LDT1,LDT2
Architectural Coating	Vendor	—	8.40	HHDT,MHDT
Architectural Coating	Hauling	0.00	20.0	HHDT
Architectural Coating	Onsite truck	—	—	HHDT

5.4. Vehicles

5.4.1. Construction Vehicle Control Strategies

Non-applicable. No control strategies activated by user.

5.5. Architectural Coatings

Phase Name	Residential Interior Area Coated (sq ft)	Residential Exterior Area Coated (sq ft)	Non-Residential Interior Area Coated (sq ft)	Non-Residential Exterior Area Coated (sq ft)	Parking Area Coated (sq ft)
------------	--	--	--	--	-----------------------------

5.6. Dust Mitigation

5.6.1. Construction Earthmoving Activities

Phase Name	Material Imported (Cubic Yards)	Material Exported (Cubic Yards)	Acres Graded (acres)	Material Demolished (sq. ft.)	Acres Paved (acres)
Site Preparation	0.00	0.00	22.5	0.00	—
Grading	261	0.00	45.0	0.00	—
Paving	0.00	0.00	0.00	0.00	0.13

5.6.2. Construction Earthmoving Control Strategies

Control Strategies Applied	Frequency (per day)	PM10 Reduction	PM2.5 Reduction
Water Exposed Area	2	61%	61%

5.7. Construction Paving

Land Use	Area Paved (acres)	% Asphalt
City Park	0.00	0%
Parking Lot	0.13	100%

5.8. Construction Electricity Consumption and Emissions Factors

kWh per Year and Emission Factor (lb/MWh)

Year	kWh per Year	CO2	CH4	N2O
2025	0.00	204	0.03	< 0.005
2026	0.00	204	0.03	< 0.005

5.9. Operational Mobile Sources

5.9.1. Unmitigated

Land Use Type	Trips/Weekday	Trips/Saturday	Trips/Sunday	Trips/Year	VMT/Weekday	VMT/Saturday	VMT/Sunday	VMT/Year
City Park	262	262	262	95,484	2,170	2,170	2,170	792,137
Parking Lot	0.00	0.00	0.00	0.00	0.00	0.00	0.00	0.00

5.9.2. Mitigated

Land Use Type	Trips/Weekday	Trips/Saturday	Trips/Sunday	Trips/Year	VMT/Weekday	VMT/Saturday	VMT/Sunday	VMT/Year
City Park	262	262	262	95,484	2,170	2,170	2,170	792,137
Parking Lot	0.00	0.00	0.00	0.00	0.00	0.00	0.00	0.00

5.10. Operational Area Sources

5.10.1. Hearths

5.10.1.1. Unmitigated

5.10.1.2. Mitigated

5.10.2. Architectural Coatings

Residential Interior Area Coated (sq ft)	Residential Exterior Area Coated (sq ft)	Non-Residential Interior Area Coated (sq ft)	Non-Residential Exterior Area Coated (sq ft)	Parking Area Coated (sq ft)
—	—	—	—	—

5.10.3. Landscape Equipment

Season	Unit	Value
Snow Days	day/yr	0.00
Summer Days	day/yr	180

5.10.4. Landscape Equipment - Mitigated

Season	Unit	Value
Snow Days	day/yr	0.00
Summer Days	day/yr	180

5.11. Operational Energy Consumption

5.11.1. Unmitigated

Electricity (kWh/yr) and CO2 and CH4 and N2O and Natural Gas (kBTU/yr)

Land Use	Electricity (kWh/yr)	CO2	CH4	N2O	Natural Gas (kBTU/yr)
----------	----------------------	-----	-----	-----	-----------------------

City Park	0.00	204	0.0330	0.0040	0.00
Parking Lot	5,151	204	0.0330	0.0040	0.00

5.11.2. Mitigated

Electricity (kWh/yr) and CO2 and CH4 and N2O and Natural Gas (kBTU/yr)

Land Use	Electricity (kWh/yr)	CO2	CH4	N2O	Natural Gas (kBTU/yr)
City Park	0.00	204	0.0330	0.0040	0.00
Parking Lot	5,151	204	0.0330	0.0040	0.00

5.12. Operational Water and Wastewater Consumption

5.12.1. Unmitigated

Land Use	Indoor Water (gal/year)	Outdoor Water (gal/year)
City Park	0.00	0.00
Parking Lot	0.00	0.00

5.12.2. Mitigated

Land Use	Indoor Water (gal/year)	Outdoor Water (gal/year)
City Park	0.00	0.00
Parking Lot	0.00	0.00

5.13. Operational Waste Generation

5.13.1. Unmitigated

Land Use	Waste (ton/year)	Cogeneration (kWh/year)
City Park	2.06	0.00
Parking Lot	0.00	0.00

5.13.2. Mitigated

Land Use	Waste (ton/year)	Cogeneration (kWh/year)
City Park	2.06	0.00
Parking Lot	0.00	0.00

5.14. Operational Refrigeration and Air Conditioning Equipment

5.14.1. Unmitigated

Land Use Type	Equipment Type	Refrigerant	GWP	Quantity (kg)	Operations Leak Rate	Service Leak Rate	Times Served
City Park	Other commercial A/C and heat pumps	R-410A	2,088	< 0.005	4.00	4.00	18.0
City Park	Stand-alone retail refrigerators and freezers	R-134a	1,430	0.04	1.00	0.00	1.00

5.14.2. Mitigated

Land Use Type	Equipment Type	Refrigerant	GWP	Quantity (kg)	Operations Leak Rate	Service Leak Rate	Times Served
City Park	Other commercial A/C and heat pumps	R-410A	2,088	< 0.005	4.00	4.00	18.0
City Park	Stand-alone retail refrigerators and freezers	R-134a	1,430	0.04	1.00	0.00	1.00

5.15. Operational Off-Road Equipment

5.15.1. Unmitigated

Equipment Type	Fuel Type	Engine Tier	Number per Day	Hours Per Day	Horsepower	Load Factor
----------------	-----------	-------------	----------------	---------------	------------	-------------

5.15.2. Mitigated

Equipment Type	Fuel Type	Engine Tier	Number per Day	Hours Per Day	Horsepower	Load Factor
----------------	-----------	-------------	----------------	---------------	------------	-------------

5.16. Stationary Sources

5.16.1. Emergency Generators and Fire Pumps

Equipment Type	Fuel Type	Number per Day	Hours per Day	Hours per Year	Horsepower	Load Factor
----------------	-----------	----------------	---------------	----------------	------------	-------------

5.16.2. Process Boilers

Equipment Type	Fuel Type	Number	Boiler Rating (MMBtu/hr)	Daily Heat Input (MMBtu/day)	Annual Heat Input (MMBtu/yr)
----------------	-----------	--------	--------------------------	------------------------------	------------------------------

5.17. User Defined

Equipment Type	Fuel Type
—	—

5.18. Vegetation

5.18.1. Land Use Change

5.18.1.1. Unmitigated

Vegetation Land Use Type	Vegetation Soil Type	Initial Acres	Final Acres
--------------------------	----------------------	---------------	-------------

5.18.1.2. Mitigated

Vegetation Land Use Type	Vegetation Soil Type	Initial Acres	Final Acres
--------------------------	----------------------	---------------	-------------

5.18.1. Biomass Cover Type

5.18.1.1. Unmitigated

Biomass Cover Type	Initial Acres	Final Acres
--------------------	---------------	-------------

5.18.1.2. Mitigated

Biomass Cover Type	Initial Acres	Final Acres
--------------------	---------------	-------------

5.18.2. Sequestration

5.18.2.1. Unmitigated

Tree Type	Number	Electricity Saved (kWh/year)	Natural Gas Saved (btu/year)
-----------	--------	------------------------------	------------------------------

5.18.2.2. Mitigated

Tree Type	Number	Electricity Saved (kWh/year)	Natural Gas Saved (btu/year)
-----------	--------	------------------------------	------------------------------

8. User Changes to Default Data

Screen	Justification
Construction: Construction Phases	Construction will start in 2025 and occur for approximately 12 months. Overlap between building construction and architectural coating phases.
Construction: Off-Road Equipment	Default construction equipment with tier 2 engine
Operations: Vehicle Data	Based on a trip generation of 262 average daily trips

APPENDIX B TRAFFIC VOLUME DATA

This page intentionally left blank

Counts Unlimited, Inc.

County of Alameda
 Carlton Avenue
 B/ Sydney Way - Keith Avenue
 24 Hour Directional Volume Count

PO Box 1178
 Corona, CA 92878
 Phone: (951) 268-6268
 email: counts@countsunlimited.com

CAM003
 Site Code: 003-23106

Start Time	2/1/23 Wed	Northbound		Hour Totals		Southbound		Hour Totals		Combined Totals	
		Morning	Afternoon	Morning	Afternoon	Morning	Afternoon	Morning	Afternoon	Morning	Afternoon
12:00		0	5			0	9				
12:15		0	8			0	5				
12:30		1	8			1	4				
12:45		0	9	1	30	0	10	1	28	2	58
01:00		0	7			0	5				
01:15		0	9			0	2				
01:30		0	9			0	5				
01:45		0	5	0	30	0	4	0	16	0	46
02:00		0	6			0	3				
02:15		0	7			0	6				
02:30		0	10			1	13				
02:45		1	12	1	35	0	10	1	32	2	67
03:00		0	20			0	10				
03:15		0	7			0	6				
03:30		0	11			0	6				
03:45		0	13	0	51	0	4	0	26	0	77
04:00		0	5			0	10				
04:15		0	14			1	5				
04:30		0	8			0	11				
04:45		1	11	1	38	1	6	2	32	3	70
05:00		1	7			0	6				
05:15		0	20			1	6				
05:30		0	7			1	8				
05:45		1	11	2	45	1	5	3	25	5	70
06:00		1	10			3	2				
06:15		1	8			3	2				
06:30		1	5			3	3				
06:45		1	4	4	27	6	4	15	11	19	38
07:00		6	4			7	1				
07:15		7	7			7	4				
07:30		4	3			9	2				
07:45		9	2	26	16	11	3	34	10	60	26
08:00		18	5			15	2				
08:15		5	4			5	2				
08:30		3	2			3	5				
08:45		5	7	31	18	6	2	29	11	60	29
09:00		5	2			8	3				
09:15		8	2			5	1				
09:30		7	6			9	2				
09:45		8	1	28	11	6	1	28	7	56	18
10:00		7	3			9	3				
10:15		4	3			10	0				
10:30		6	1			7	0				
10:45		5	2	22	9	2	1	28	4	50	13
11:00		3	2			8	0				
11:15		11	0			6	2				
11:30		6	0			5	1				
11:45		8	2	28	4	4	0	23	3	51	7
Total		144	314	144	314	164	205	164	205	308	519
Combined Total		458		458		369		369		827	
AM Peak	-	07:15	-	-	-	07:15	-	-	-	-	-
Vol.	-	38	-	-	-	42	-	-	-	-	-
P.H.F.		0.528				0.700					
PM Peak	-	-	03:00	-	-	-	02:15	-	-	-	-
Vol.	-	-	51	-	-	-	39	-	-	-	-
P.H.F.			0.638				0.750				
Percentage		31.4%	68.6%			44.4%	55.6%				
ADT/AADT		ADT 827		AADT 827							

Counts Unlimited, Inc.

County of Alameda
 Lake Chabot Road
 B/ Fairmont Drive - Seven Hills Road
 24 Hour Directional Volume Count

PO Box 1178
 Corona, CA 92878
 Phone: (951) 268-6268
 email: counts@countsunlimited.com

CAM005
 Site Code: 003-23106

Start Time	2/1/23 Wed	Northbound		Hour Totals		Southbound		Hour Totals		Combined Totals	
		Morning	Afternoon	Morning	Afternoon	Morning	Afternoon	Morning	Afternoon	Morning	Afternoon
12:00		1	72			3	74				
12:15		0	75			6	69				
12:30		3	80			2	84				
12:45		2	64	6	291	0	85	11	312	17	603
01:00		1	89			1	75				
01:15		1	69			2	74				
01:30		1	65			2	71				
01:45		2	97	5	320	2	82	7	302	12	622
02:00		3	70			1	79				
02:15		2	74			2	87				
02:30		1	82			0	103				
02:45		0	106	6	332	0	90	3	359	9	691
03:00		0	81			1	98				
03:15		1	91			0	130				
03:30		0	109			1	97				
03:45		3	143	4	424	1	102	3	427	7	851
04:00		2	111			3	90				
04:15		4	95			3	109				
04:30		5	109			5	128				
04:45		13	117	24	432	7	139	18	466	42	898
05:00		8	121			6	128				
05:15		15	95			10	109				
05:30		16	88			7	104				
05:45		27	86	66	390	16	95	39	436	105	826
06:00		34	66			20	100				
06:15		27	60			19	81				
06:30		50	52			18	74				
06:45		53	42	164	220	25	65	82	320	246	540
07:00		51	48			41	51				
07:15		110	49			62	37				
07:30		117	45			66	36				
07:45		123	47	401	189	121	41	290	165	691	354
08:00		178	41			110	24				
08:15		124	37			94	27				
08:30		138	25			84	19				
08:45		108	22	548	125	82	24	370	94	918	219
09:00		71	34			69	22				
09:15		81	16			57	8				
09:30		63	19			52	18				
09:45		70	13	285	82	58	19	236	67	521	149
10:00		59	16			56	13				
10:15		66	14			55	15				
10:30		66	8			54	9				
10:45		64	3	255	41	68	6	233	43	488	84
11:00		78	5			68	13				
11:15		63	8			62	10				
11:30		64	7			76	7				
11:45		70	2	275	22	60	10	266	40	541	62
Total		2039	2868	2039	2868	1558	3031	1558	3031	3597	5899
Combined Total		4907		4907		4589		4589		9496	
AM Peak	-	07:45	-	-	-	07:45	-	-	-	-	-
Vol.	-	563	-	-	-	409	-	-	-	-	-
P.H.F.	-	0.791	-	-	-	0.845	-	-	-	-	-
PM Peak	-	-	03:30	-	-	-	04:15	-	-	-	-
Vol.	-	-	458	-	-	-	504	-	-	-	-
P.H.F.	-	-	0.801	-	-	-	0.906	-	-	-	-
Percentage		41.6%	58.4%			34.0%	66.0%				
ADT/AADT		ADT 9,496		AADT 9,496							

County of Alameda
 N/S: Lake Chabot Road
 E/W: Sydney Way/Seven Hills Road
 Weather: Clear

File Name : 01_CAM_LC_Syd AM
 Site Code : 00323106
 Start Date : 2/1/2023
 Page No : 1

Groups Printed- Total Volume

Start Time	Lake Chabot Road Southbound				Seven Hills Road Westbound				Lake Chabot Road Northbound				Sydney Way Eastbound				Int. Total
	Left	Thru	Right	App. Total	Left	Thru	Right	App. Total	Left	Thru	Right	App. Total	Left	Thru	Right	App. Total	
07:00 AM	6	33	2	41	8	2	24	34	2	25	5	32	2	8	5	15	122
07:15 AM	24	36	2	62	9	4	61	74	2	44	3	49	5	6	9	20	205
07:30 AM	21	44	1	66	5	5	75	85	2	40	0	42	2	10	8	20	213
07:45 AM	33	88	0	121	16	8	69	93	6	51	7	64	3	29	17	49	327
Total	84	201	5	290	38	19	229	286	12	160	15	187	12	53	39	104	867
08:00 AM	32	76	2	110	8	19	77	104	18	98	6	122	3	32	17	52	388
08:15 AM	44	49	1	94	14	9	65	88	5	57	7	69	2	21	10	33	284
08:30 AM	25	57	2	84	9	8	69	86	2	67	11	80	2	3	5	10	260
08:45 AM	26	53	3	82	11	7	48	66	4	55	4	63	5	5	3	13	224
Total	127	235	8	370	42	43	259	344	29	277	28	334	12	61	35	108	1156
Grand Total	211	436	13	660	80	62	488	630	41	437	43	521	24	114	74	212	2023
Apprch %	32	66.1	2		12.7	9.8	77.5		7.9	83.9	8.3		11.3	53.8	34.9		
Total %	10.4	21.6	0.6	32.6	4	3.1	24.1	31.1	2	21.6	2.1	25.8	1.2	5.6	3.7	10.5	

Start Time	Lake Chabot Road Southbound				Seven Hills Road Westbound				Lake Chabot Road Northbound				Sydney Way Eastbound				Int. Total
	Left	Thru	Right	App. Total	Left	Thru	Right	App. Total	Left	Thru	Right	App. Total	Left	Thru	Right	App. Total	
07:45 AM	33	88	0	121	16	8	69	93	6	51	7	64	3	29	17	49	327
08:00 AM	32	76	2	110	8	19	77	104	18	98	6	122	3	32	17	52	388
08:15 AM	44	49	1	94	14	9	65	88	5	57	7	69	2	21	10	33	284
08:30 AM	25	57	2	84	9	8	69	86	2	67	11	80	2	3	5	10	260
Total Volume	134	270	5	409	47	44	280	371	31	273	31	335	10	85	49	144	1259
% App. Total	32.8	66	1.2		12.7	11.9	75.5		9.3	81.5	9.3		6.9	59	34		
PHF	.761	.767	.625	.845	.734	.579	.909	.892	.431	.696	.705	.686	.833	.664	.721	.692	.811

Peak Hour Analysis From 07:00 AM to 08:45 AM - Peak 1 of 1

Peak Hour for Entire Intersection Begins at 07:45 AM

County of Alameda
 N/S: Lake Chabot Road
 E/W: Sydney Way/Seven Hills Road
 Weather: Clear

File Name : 01_CAM_LC_Syd AM
 Site Code : 00323106
 Start Date : 2/1/2023
 Page No : 2

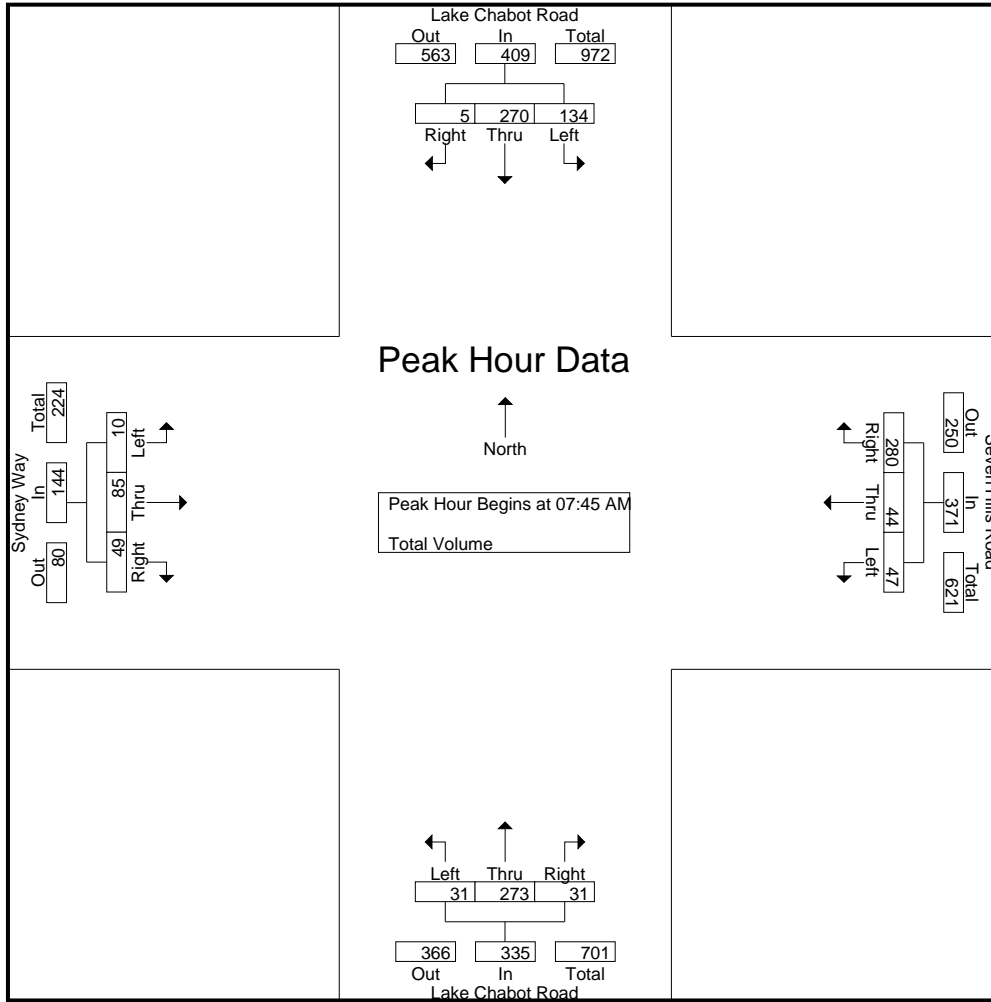

Peak Hour Analysis From 07:00 AM to 08:45 AM - Peak 1 of 1
 Peak Hour for Each Approach Begins at:

	07:45 AM				07:45 AM				07:45 AM				07:30 AM			
+0 mins.	33	88	0	121	16	8	69	93	6	51	7	64	2	10	8	20
+15 mins.	32	76	2	110	8	19	77	104	18	98	6	122	3	29	17	49
+30 mins.	44	49	1	94	14	9	65	88	5	57	7	69	3	32	17	52
+45 mins.	25	57	2	84	9	8	69	86	2	67	11	80	2	21	10	33
Total Volume	134	270	5	409	47	44	280	371	31	273	31	335	10	92	52	154
% App. Total	32.8	66	1.2		12.7	11.9	75.5		9.3	81.5	9.3		6.5	59.7	33.8	
PHF	.761	.767	.625	.845	.734	.579	.909	.892	.431	.696	.705	.686	.833	.719	.765	.740

County of Alameda
 N/S: Lake Chabot Road
 E/W: Sydney Way/Seven Hills Road
 Weather: Clear

File Name : 01_CAM_LC_Syd PM
 Site Code : 00323106
 Start Date : 2/1/2023
 Page No : 1

Groups Printed- Total Volume

Start Time	Lake Chabot Road Southbound				Seven Hills Road Westbound				Lake Chabot Road Northbound				Sydney Way Eastbound				Int. Total
	Left	Thru	Right	App. Total	Left	Thru	Right	App. Total	Left	Thru	Right	App. Total	Left	Thru	Right	App. Total	
04:00 PM	26	63	1	90	5	4	38	47	5	73	7	85	0	6	8	14	236
04:15 PM	38	69	2	109	8	9	39	56	6	56	6	68	0	9	7	16	249
04:30 PM	50	77	1	128	3	10	30	43	9	74	11	94	5	11	6	22	287
04:45 PM	56	79	4	139	5	9	32	46	11	81	7	99	4	11	5	20	304
Total	170	288	8	466	21	32	139	192	31	284	31	346	9	37	26	72	1076
05:00 PM	43	83	2	128	7	17	38	62	4	82	5	91	1	7	5	13	294
05:15 PM	37	71	1	109	5	4	33	42	7	61	15	83	1	10	3	14	248
05:30 PM	34	67	3	104	3	6	33	42	6	52	12	70	3	5	6	14	230
05:45 PM	38	56	1	95	6	5	32	43	3	51	9	63	3	2	4	9	210
Total	152	277	7	436	21	32	136	189	20	246	41	307	8	24	18	50	982
Grand Total	322	565	15	902	42	64	275	381	51	530	72	653	17	61	44	122	2058
Apprch %	35.7	62.6	1.7		11	16.8	72.2		7.8	81.2	11		13.9	50	36.1		
Total %	15.6	27.5	0.7	43.8	2	3.1	13.4	18.5	2.5	25.8	3.5	31.7	0.8	3	2.1	5.9	

Start Time	Lake Chabot Road Southbound				Seven Hills Road Westbound				Lake Chabot Road Northbound				Sydney Way Eastbound				Int. Total
	Left	Thru	Right	App. Total	Left	Thru	Right	App. Total	Left	Thru	Right	App. Total	Left	Thru	Right	App. Total	
Peak Hour Analysis From 04:00 PM to 05:45 PM - Peak 1 of 1																	
Peak Hour for Entire Intersection Begins at 04:15 PM																	
04:15 PM	38	69	2	109	8	9	39	56	6	56	6	68	0	9	7	16	249
04:30 PM	50	77	1	128	3	10	30	43	9	74	11	94	5	11	6	22	287
04:45 PM	56	79	4	139	5	9	32	46	11	81	7	99	4	11	5	20	304
05:00 PM	43	83	2	128	7	17	38	62	4	82	5	91	1	7	5	13	294
Total Volume	187	308	9	504	23	45	139	207	30	293	29	352	10	38	23	71	1134
% App. Total	37.1	61.1	1.8		11.1	21.7	67.1		8.5	83.2	8.2		14.1	53.5	32.4		
PHF	.835	.928	.563	.906	.719	.662	.891	.835	.682	.893	.659	.889	.500	.864	.821	.807	.933

County of Alameda
 N/S: Lake Chabot Road
 E/W: Sydney Way/Seven Hills Road
 Weather: Clear

File Name : 01_CAM_LC_Syd PM
 Site Code : 00323106
 Start Date : 2/1/2023
 Page No : 2

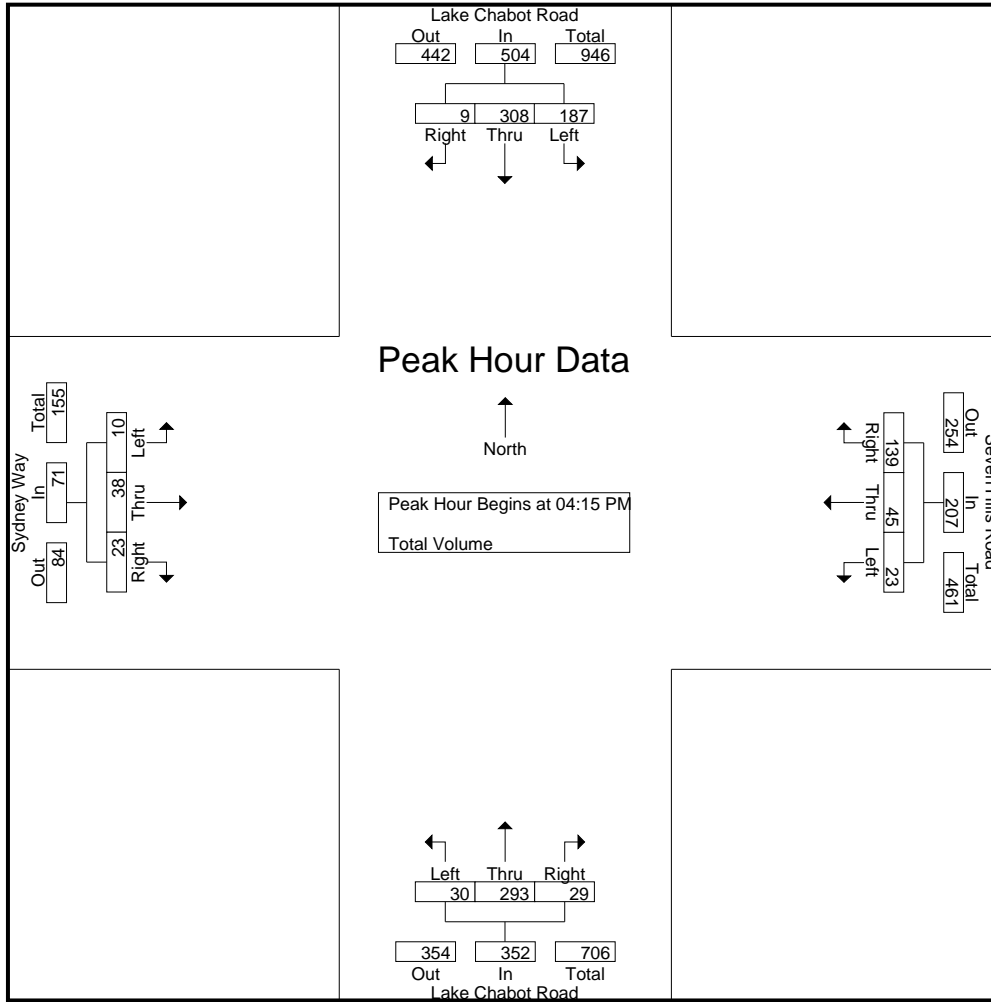

Peak Hour Analysis From 04:00 PM to 05:45 PM - Peak 1 of 1
 Peak Hour for Each Approach Begins at:

	04:15 PM				04:15 PM				04:30 PM				04:00 PM			
+0 mins.	38	69	2	109	8	9	39	56	9	74	11	94	0	6	8	14
+15 mins.	50	77	1	128	3	10	30	43	11	81	7	99	0	9	7	16
+30 mins.	56	79	4	139	5	9	32	46	4	82	5	91	5	11	6	22
+45 mins.	43	83	2	128	7	17	38	62	7	61	15	83	4	11	5	20
Total Volume	187	308	9	504	23	45	139	207	31	298	38	367	9	37	26	72
% App. Total	37.1	61.1	1.8		11.1	21.7	67.1		8.4	81.2	10.4		12.5	51.4	36.1	
PHF	.835	.928	.563	.906	.719	.662	.891	.835	.705	.909	.633	.927	.450	.841	.813	.818

County of Alameda
 N/S: Stanton Avenue
 E/W: Sydney Way
 Weather: Clear

File Name : 02_CAM_Stan_Syd AM
 Site Code : 00323106
 Start Date : 2/1/2023
 Page No : 1

Groups Printed- Total Volume

Start Time	Stanton Avenue Southbound				Sydney Way Westbound				Stanton Avenue Northbound				Private Driveway Eastbound				Int. Total
	Left	Thru	Right	App. Total	Left	Thru	Right	App. Total	Left	Thru	Right	App. Total	Left	Thru	Right	App. Total	
07:00 AM	2	6	0	8	1	0	0	1	0	1	2	3	0	0	0	0	12
07:15 AM	9	6	0	15	5	0	0	5	0	2	4	6	0	0	0	0	26
07:30 AM	6	10	0	16	16	0	3	19	2	4	2	8	0	0	0	0	43
07:45 AM	11	11	0	22	12	0	1	13	0	3	12	15	0	0	0	0	50
Total	28	33	0	61	34	0	4	38	2	10	20	32	0	0	0	0	131
08:00 AM	15	14	0	29	27	0	8	35	2	7	16	25	0	0	0	0	89
08:15 AM	12	4	0	16	11	0	6	17	1	6	20	27	0	0	0	0	60
08:30 AM	3	9	0	12	11	0	4	15	0	7	8	15	0	0	0	0	42
08:45 AM	6	2	0	8	11	0	5	16	1	4	0	5	0	0	0	0	29
Total	36	29	0	65	60	0	23	83	4	24	44	72	0	0	0	0	220
Grand Total	64	62	0	126	94	0	27	121	6	34	64	104	0	0	0	0	351
Apprch %	50.8	49.2	0		77.7	0	22.3		5.8	32.7	61.5		0	0	0		
Total %	18.2	17.7	0	35.9	26.8	0	7.7	34.5	1.7	9.7	18.2	29.6	0	0	0	0	

Start Time	Stanton Avenue Southbound				Sydney Way Westbound				Stanton Avenue Northbound				Private Driveway Eastbound				Int. Total
	Left	Thru	Right	App. Total	Left	Thru	Right	App. Total	Left	Thru	Right	App. Total	Left	Thru	Right	App. Total	
Peak Hour Analysis From 07:00 AM to 08:45 AM - Peak 1 of 1																	
Peak Hour for Entire Intersection Begins at 07:30 AM																	
07:30 AM	6	10	0	16	16	0	3	19	2	4	2	8	0	0	0	0	43
07:45 AM	11	11	0	22	12	0	1	13	0	3	12	15	0	0	0	0	50
08:00 AM	15	14	0	29	27	0	8	35	2	7	16	25	0	0	0	0	89
08:15 AM	12	4	0	16	11	0	6	17	1	6	20	27	0	0	0	0	60
Total Volume	44	39	0	83	66	0	18	84	5	20	50	75	0	0	0	0	242
% App. Total	53	47	0		78.6	0	21.4		6.7	26.7	66.7		0	0	0		
PHF	.733	.696	.000	.716	.611	.000	.563	.600	.625	.714	.625	.694	.000	.000	.000	.000	.680

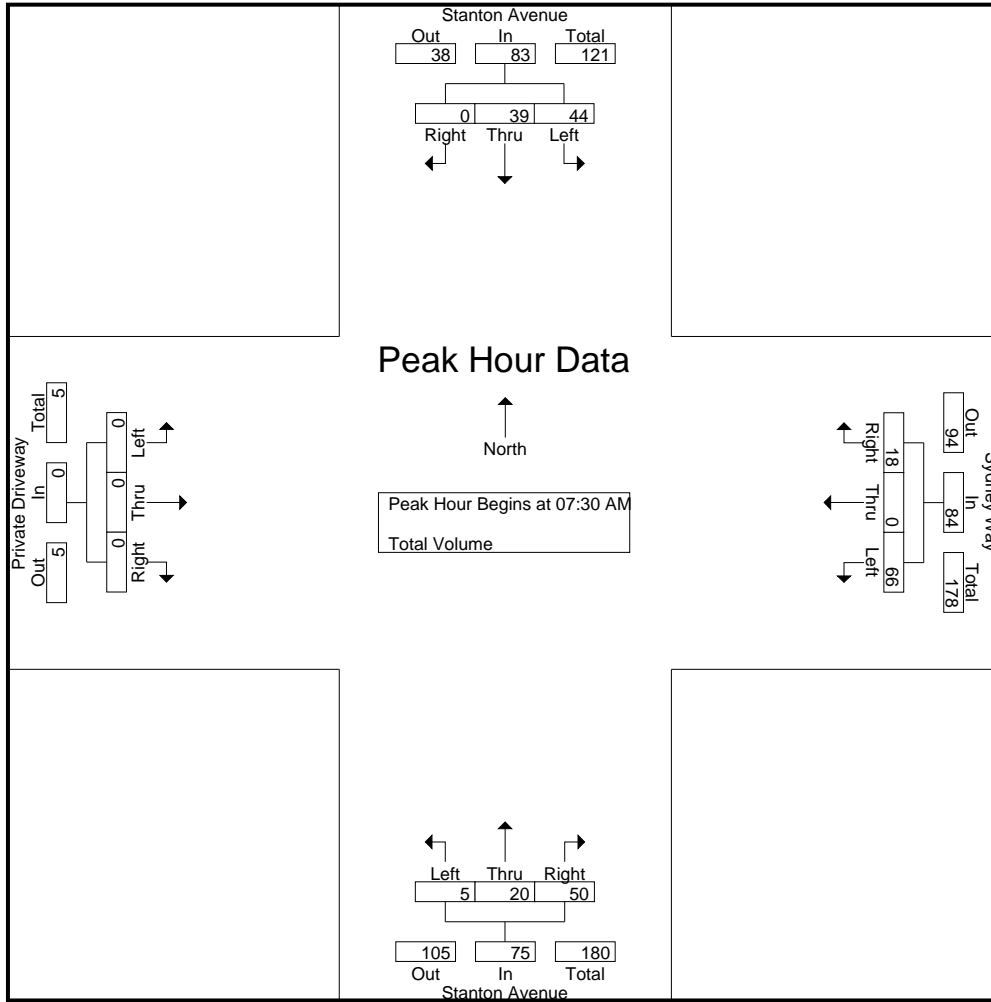

Peak Hour Analysis From 07:00 AM to 08:45 AM - Peak 1 of 1
 Peak Hour for Each Approach Begins at:

	07:30 AM				07:30 AM				07:45 AM				07:00 AM			
+0 mins.	6	10	0	16	16	0	3	19	0	3	12	15	0	0	0	0
+15 mins.	11	11	0	22	12	0	1	13	2	7	16	25	0	0	0	0
+30 mins.	15	14	0	29	27	0	8	35	1	6	20	27	0	0	0	0
+45 mins.	12	4	0	16	11	0	6	17	0	7	8	15	0	0	0	0
Total Volume	44	39	0	83	66	0	18	84	3	23	56	82	0	0	0	0
% App. Total	53	47	0		78.6	0	21.4		3.7	28	68.3		0	0	0	
PHF	.733	.696	.000	.716	.611	.000	.563	.600	.375	.821	.700	.759	.000	.000	.000	.000

County of Alameda
 N/S: Stanton Avenue
 E/W: Sydney Way
 Weather: Clear

File Name : 02_CAM_Stan_Syd PM
 Site Code : 00323106
 Start Date : 2/1/2023
 Page No : 1

Groups Printed- Total Volume

Start Time	Stanton Avenue Southbound				Sydney Way Westbound				Stanton Avenue Northbound				Private Driveway Eastbound				Int. Total
	Left	Thru	Right	App. Total	Left	Thru	Right	App. Total	Left	Thru	Right	App. Total	Left	Thru	Right	App. Total	
04:00 PM	5	5	0	10	9	0	3	12	0	9	9	18	0	0	0	0	40
04:15 PM	4	6	0	10	3	0	6	9	0	4	4	8	0	0	0	0	27
04:30 PM	6	6	0	12	7	0	7	14	0	10	12	22	0	0	0	0	48
04:45 PM	4	7	0	11	6	0	7	13	0	8	10	18	0	0	0	0	42
Total	19	24	0	43	25	0	23	48	0	31	35	66	0	0	0	0	157
05:00 PM	8	6	0	14	12	0	6	18	0	14	11	25	0	0	0	0	57
05:15 PM	4	3	0	7	9	0	11	20	0	5	10	15	0	0	0	0	42
05:30 PM	3	3	0	6	11	0	6	17	0	3	11	14	0	0	0	0	37
05:45 PM	2	2	0	4	6	0	7	13	1	7	10	18	0	0	0	0	35
Total	17	14	0	31	38	0	30	68	1	29	42	72	0	0	0	0	171
Grand Total	36	38	0	74	63	0	53	116	1	60	77	138	0	0	0	0	328
Apprch %	48.6	51.4	0		54.3	0	45.7		0.7	43.5	55.8		0	0	0		
Total %	11	11.6	0	22.6	19.2	0	16.2	35.4	0.3	18.3	23.5	42.1	0	0	0	0	

Start Time	Stanton Avenue Southbound				Sydney Way Westbound				Stanton Avenue Northbound				Private Driveway Eastbound				Int. Total
	Left	Thru	Right	App. Total	Left	Thru	Right	App. Total	Left	Thru	Right	App. Total	Left	Thru	Right	App. Total	
04:30 PM	6	6	0	12	7	0	7	14	0	10	12	22	0	0	0	0	48
04:45 PM	4	7	0	11	6	0	7	13	0	8	10	18	0	0	0	0	42
05:00 PM	8	6	0	14	12	0	6	18	0	14	11	25	0	0	0	0	57
05:15 PM	4	3	0	7	9	0	11	20	0	5	10	15	0	0	0	0	42
Total Volume	22	22	0	44	34	0	31	65	0	37	43	80	0	0	0	0	189
% App. Total	50	50	0		52.3	0	47.7		0	46.2	53.8		0	0	0		
PHF	.688	.786	.000	.786	.708	.000	.705	.813	.000	.661	.896	.800	.000	.000	.000	.000	.829

Peak Hour Analysis From 04:00 PM to 05:45 PM - Peak 1 of 1

Peak Hour for Entire Intersection Begins at 04:30 PM

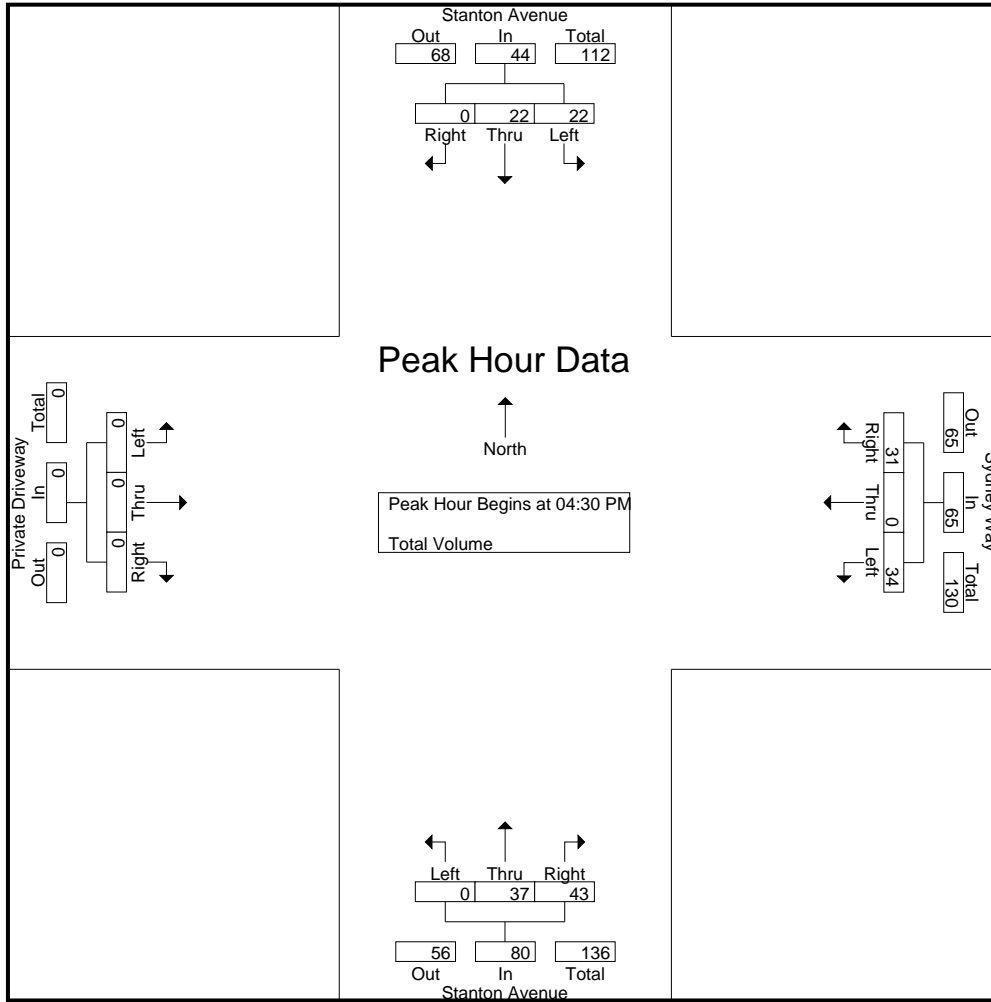

Peak Hour Analysis From 04:00 PM to 05:45 PM - Peak 1 of 1
 Peak Hour for Each Approach Begins at:

	04:15 PM				04:45 PM				04:30 PM				04:00 PM			
+0 mins.	4	6	0	10	6	0	7	13	0	10	12	22	0	0	0	0
+15 mins.	6	6	0	12	12	0	6	18	0	8	10	18	0	0	0	0
+30 mins.	4	7	0	11	9	0	11	20	0	14	11	25	0	0	0	0
+45 mins.	8	6	0	14	11	0	6	17	0	5	10	15	0	0	0	0
Total Volume	22	25	0	47	38	0	30	68	0	37	43	80	0	0	0	0
% App. Total	46.8	53.2	0		55.9	0	44.1		0	46.2	53.8		0	0	0	
PHF	.688	.893	.000	.839	.792	.000	.682	.850	.000	.661	.896	.800	.000	.000	.000	.000

County of Alameda
 N/S: Carlton Avenue
 E/W: Severini Lane/Keith Avenue
 Weather: Clear

File Name : 03_CAM_Carl_Sev AM
 Site Code : 00323106
 Start Date : 2/1/2023
 Page No : 1

Groups Printed- Total Volume

Start Time	Carlton Avenue Southbound				Keith Avenue Westbound				Carlton Avenue Northbound				Severini Lane Eastbound				Int. Total
	Left	Thru	Right	App. Total	Left	Thru	Right	App. Total	Left	Thru	Right	App. Total	Left	Thru	Right	App. Total	
07:00 AM	0	7	0	7	1	0	2	3	0	4	2	6	0	0	0	0	16
07:15 AM	0	7	0	7	3	0	0	3	0	7	1	8	0	0	0	0	18
07:30 AM	2	7	0	9	6	0	1	7	0	3	2	5	0	0	0	0	21
07:45 AM	3	8	0	11	4	0	1	5	0	8	4	12	0	0	0	0	28
Total	5	29	0	34	14	0	4	18	0	22	9	31	0	0	0	0	83
08:00 AM	7	8	0	15	9	0	7	16	0	11	8	19	0	0	0	0	50
08:15 AM	1	4	0	5	4	0	1	5	0	4	3	7	0	0	0	0	17
08:30 AM	0	3	0	3	5	0	0	5	0	3	3	6	0	0	0	0	14
08:45 AM	1	5	0	6	2	0	1	3	0	4	1	5	0	0	0	0	14
Total	9	20	0	29	20	0	9	29	0	22	15	37	0	0	0	0	95
Grand Total	14	49	0	63	34	0	13	47	0	44	24	68	0	0	0	0	178
Apprch %	22.2	77.8	0		72.3	0	27.7		0	64.7	35.3		0	0	0		
Total %	7.9	27.5	0	35.4	19.1	0	7.3	26.4	0	24.7	13.5	38.2	0	0	0	0	

Start Time	Carlton Avenue Southbound				Keith Avenue Westbound				Carlton Avenue Northbound				Severini Lane Eastbound				Int. Total
	Left	Thru	Right	App. Total	Left	Thru	Right	App. Total	Left	Thru	Right	App. Total	Left	Thru	Right	App. Total	
07:15 AM	0	7	0	7	3	0	0	3	0	7	1	8	0	0	0	0	18
07:30 AM	2	7	0	9	6	0	1	7	0	3	2	5	0	0	0	0	21
07:45 AM	3	8	0	11	4	0	1	5	0	8	4	12	0	0	0	0	28
08:00 AM	7	8	0	15	9	0	7	16	0	11	8	19	0	0	0	0	50
Total Volume	12	30	0	42	22	0	9	31	0	29	15	44	0	0	0	0	117
% App. Total	28.6	71.4	0		71	0	29		0	65.9	34.1		0	0	0		
PHF	.429	.938	.000	.700	.611	.000	.321	.484	.000	.659	.469	.579	.000	.000	.000	.000	.585

Peak Hour Analysis From 07:00 AM to 08:45 AM - Peak 1 of 1
 Peak Hour for Entire Intersection Begins at 07:15 AM

County of Alameda
 N/S: Carlton Avenue
 E/W: Severini Lane/Keith Avenue
 Weather: Clear

File Name : 03_CAM_Carl_Sev AM
 Site Code : 00323106
 Start Date : 2/1/2023
 Page No : 2

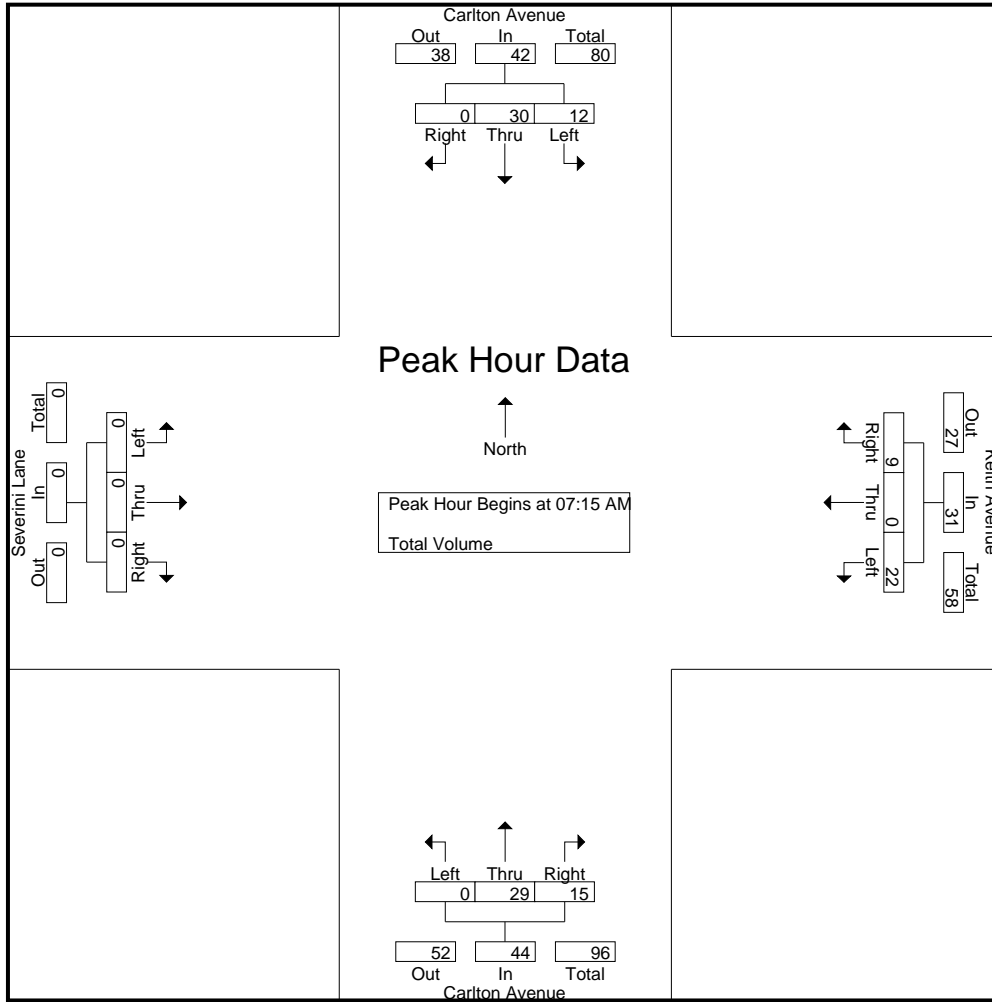

Peak Hour Analysis From 07:00 AM to 08:45 AM - Peak 1 of 1
 Peak Hour for Each Approach Begins at:

	07:15 AM				07:30 AM				07:15 AM				07:00 AM			
+0 mins.	0	7	0	7	6	0	1	7	0	7	1	8	0	0	0	0
+15 mins.	2	7	0	9	4	0	1	5	0	3	2	5	0	0	0	0
+30 mins.	3	8	0	11	9	0	7	16	0	8	4	12	0	0	0	0
+45 mins.	7	8	0	15	4	0	1	5	0	11	8	19	0	0	0	0
Total Volume	12	30	0	42	23	0	10	33	0	29	15	44	0	0	0	0
% App. Total	28.6	71.4	0		69.7	0	30.3		0	65.9	34.1		0	0	0	
PHF	.429	.938	.000	.700	.639	.000	.357	.516	.000	.659	.469	.579	.000	.000	.000	.000

County of Alameda
 N/S: Carlton Avenue
 E/W: Severini Lane/Keith Avenue
 Weather: Clear

File Name : 03_CAM_Carl_Sev PM
 Site Code : 00323106
 Start Date : 2/1/2023
 Page No : 1

Groups Printed- Total Volume

Start Time	Carlton Avenue Southbound				Keith Avenue Westbound				Carlton Avenue Northbound				Severini Lane Eastbound				Int. Total
	Left	Thru	Right	App. Total	Left	Thru	Right	App. Total	Left	Thru	Right	App. Total	Left	Thru	Right	App. Total	
04:00 PM	4	6	0	10	0	0	0	0	0	5	7	12	0	0	0	0	22
04:15 PM	0	5	0	5	4	0	3	7	0	11	2	13	0	0	0	0	25
04:30 PM	5	6	0	11	2	0	3	5	1	5	1	7	0	0	0	0	23
04:45 PM	1	5	0	6	2	0	2	4	0	9	3	12	0	0	0	0	22
Total	10	22	0	32	8	0	8	16	1	30	13	44	0	0	0	0	92
05:00 PM	1	5	0	6	4	0	0	4	0	7	3	10	0	0	0	0	20
05:15 PM	2	4	0	6	0	1	6	7	0	14	3	17	0	0	0	0	30
05:30 PM	1	7	0	8	2	0	1	3	0	6	2	8	0	0	0	0	19
05:45 PM	1	4	0	5	3	0	0	3	0	11	1	12	0	0	0	0	20
Total	5	20	0	25	9	1	7	17	0	38	9	47	0	0	0	0	89
Grand Total	15	42	0	57	17	1	15	33	1	68	22	91	0	0	0	0	181
Apprch %	26.3	73.7	0		51.5	3	45.5		1.1	74.7	24.2		0	0	0		
Total %	8.3	23.2	0	31.5	9.4	0.6	8.3	18.2	0.6	37.6	12.2	50.3	0	0	0	0	

Start Time	Carlton Avenue Southbound				Keith Avenue Westbound				Carlton Avenue Northbound				Severini Lane Eastbound				Int. Total
	Left	Thru	Right	App. Total	Left	Thru	Right	App. Total	Left	Thru	Right	App. Total	Left	Thru	Right	App. Total	
04:30 PM	5	6	0	11	2	0	3	5	1	5	1	7	0	0	0	0	23
04:45 PM	1	5	0	6	2	0	2	4	0	9	3	12	0	0	0	0	22
05:00 PM	1	5	0	6	4	0	0	4	0	7	3	10	0	0	0	0	20
05:15 PM	2	4	0	6	0	1	6	7	0	14	3	17	0	0	0	0	30
Total Volume	9	20	0	29	8	1	11	20	1	35	10	46	0	0	0	0	95
% App. Total	31	69	0		40	5	55		2.2	76.1	21.7		0	0	0		
PHF	.450	.833	.000	.659	.500	.250	.458	.714	.250	.625	.833	.676	.000	.000	.000	.000	.792

Peak Hour Analysis From 04:00 PM to 05:45 PM - Peak 1 of 1

Peak Hour for Entire Intersection Begins at 04:30 PM

County of Alameda
 N/S: Carlton Avenue
 E/W: Severini Lane/Keith Avenue
 Weather: Clear

File Name : 03_CAM_Carl_Sev PM
 Site Code : 00323106
 Start Date : 2/1/2023
 Page No : 2

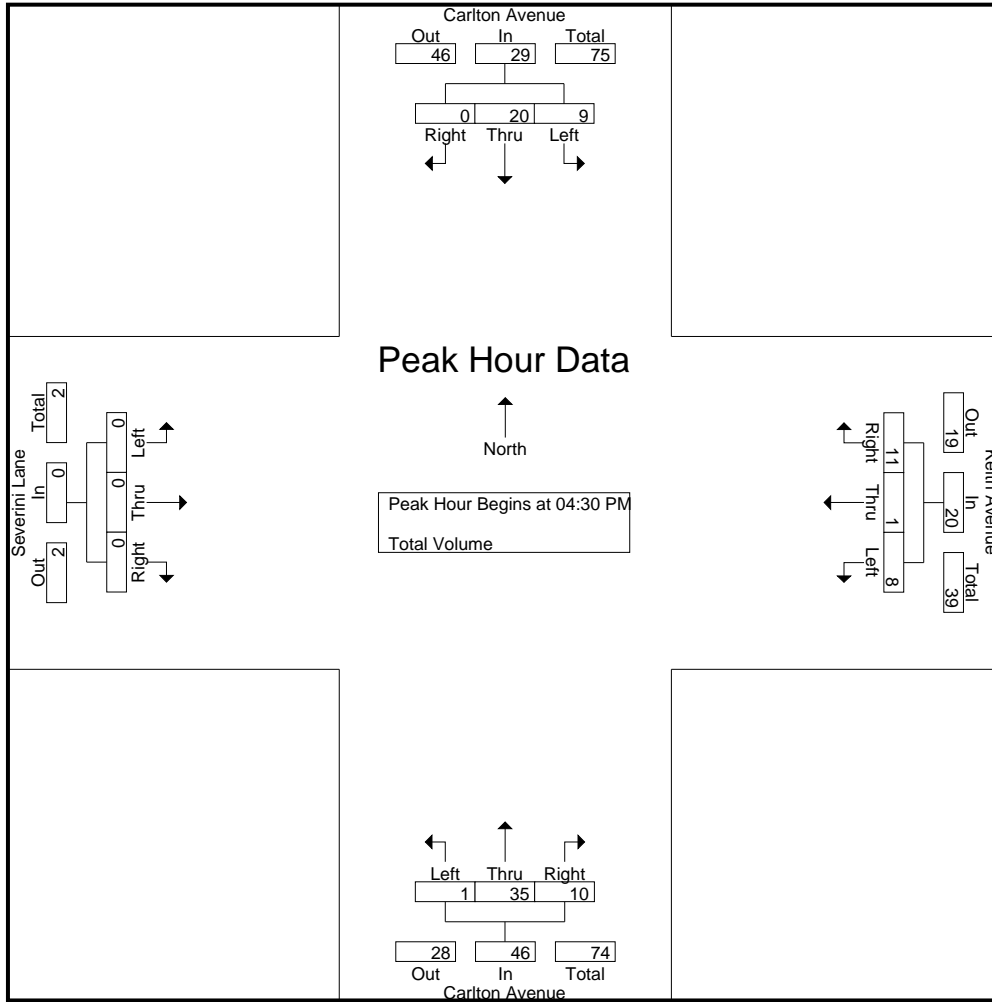

Peak Hour Analysis From 04:00 PM to 05:45 PM - Peak 1 of 1
 Peak Hour for Each Approach Begins at:

	04:00 PM				04:15 PM				04:45 PM				04:00 PM			
+0 mins.	4	6	0	10	4	0	3	7	0	9	3	12	0	0	0	0
+15 mins.	0	5	0	5	2	0	3	5	0	7	3	10	0	0	0	0
+30 mins.	5	6	0	11	2	0	2	4	0	14	3	17	0	0	0	0
+45 mins.	1	5	0	6	4	0	0	4	0	6	2	8	0	0	0	0
Total Volume	10	22	0	32	12	0	8	20	0	36	11	47	0	0	0	0
% App. Total	31.2	68.8	0		60	0	40		0	76.6	23.4		0	0	0	
PHF	.500	.917	.000	.727	.750	.000	.667	.714	.000	.643	.917	.691	.000	.000	.000	.000

HCM 6th Signalized Intersection Summary

1: Lake Chabot Road & Sydney Way/Seven Hills Road

04/10/2023

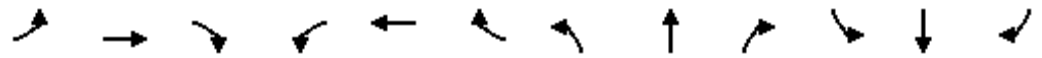

Movement	EBL	EBT	EBR	WBL	WBT	WBR	NBL	NBT	NBR	SBL	SBT	SBR
Lane Configurations		↕	↗		↕	↗	↗	↕↕		↗	↕↕	
Traffic Volume (veh/h)	10	85	49	47	44	280	31	273	31	134	270	5
Future Volume (veh/h)	10	85	49	47	44	280	31	273	31	134	270	5
Initial Q (Qb), veh	0	0	0	0	0	0	0	0	0	0	0	0
Ped-Bike Adj(A_pbT)	1.00		1.00	1.00		1.00	1.00		1.00	1.00		1.00
Parking Bus, Adj	1.00	1.00	1.00	1.00	1.00	1.00	1.00	1.00	1.00	1.00	1.00	1.00
Work Zone On Approach		No			No			No			No	
Adj Sat Flow, veh/h/ln	1870	1870	1870	1870	1870	1870	1870	1870	1870	1870	1870	1870
Adj Flow Rate, veh/h	11	89	52	49	46	0	33	287	33	141	284	5
Peak Hour Factor	0.95	0.95	0.95	0.95	0.95	0.95	0.95	0.95	0.95	0.95	0.95	0.95
Percent Heavy Veh, %	2	2	2	2	2	2	2	2	2	2	2	2
Cap, veh/h	112	223	204	195	101		68	1415	161	179	1796	32
Arrive On Green	0.13	0.13	0.13	0.13	0.13	0.00	0.04	0.44	0.44	0.10	0.50	0.50
Sat Flow, veh/h	112	1729	1585	475	784	1585	1781	3215	366	1781	3573	63
Grp Volume(v), veh/h	100	0	52	95	0	0	33	157	163	141	141	148
Grp Sat Flow(s),veh/h/ln	1841	0	1585	1259	0	1585	1781	1777	1804	1781	1777	1859
Q Serve(g_s), s	0.0	0.0	1.2	1.3	0.0	0.0	0.7	2.2	2.3	3.2	1.8	1.8
Cycle Q Clear(g_c), s	2.0	0.0	1.2	3.3	0.0	0.0	0.7	2.2	2.3	3.2	1.8	1.8
Prop In Lane	0.11		1.00	0.52		1.00	1.00		0.20	1.00		0.03
Lane Grp Cap(c), veh/h	335	0	204	296	0		68	782	794	179	893	934
V/C Ratio(X)	0.30	0.00	0.25	0.32	0.00		0.48	0.20	0.20	0.79	0.16	0.16
Avail Cap(c_a), veh/h	894	0	698	759	0		218	782	794	218	893	934
HCM Platoon Ratio	1.00	1.00	1.00	1.00	1.00	1.00	1.00	1.00	1.00	1.00	1.00	1.00
Upstream Filter(I)	1.00	0.00	1.00	1.00	0.00	0.00	1.00	1.00	1.00	1.00	1.00	1.00
Uniform Delay (d), s/veh	16.4	0.0	16.0	16.9	0.0	0.0	19.3	7.0	7.0	18.0	5.5	5.5
Incr Delay (d2), s/veh	0.5	0.0	0.6	0.6	0.0	0.0	5.3	0.6	0.6	14.3	0.4	0.4
Initial Q Delay(d3),s/veh	0.0	0.0	0.0	0.0	0.0	0.0	0.0	0.0	0.0	0.0	0.0	0.0
%ile BackOfQ(50%),veh/ln	0.8	0.0	0.4	0.8	0.0	0.0	0.4	0.7	0.7	1.8	0.5	0.5
Unsig. Movement Delay, s/veh												
LnGrp Delay(d),s/veh	16.9	0.0	16.7	17.5	0.0	0.0	24.5	7.6	7.6	32.3	5.9	5.9
LnGrp LOS	B	A	B	B	A		C	A	A	C	A	A
Approach Vol, veh/h		152			95			353			430	
Approach Delay, s/veh		16.8			17.5			9.2			14.5	
Approach LOS		B			B			A			B	
Timer - Assigned Phs	1	2		4	5	6		8				
Phs Duration (G+Y+Rc), s	8.6	22.5		9.8	6.1	25.1		9.8				
Change Period (Y+Rc), s	4.5	4.5		4.5	4.5	4.5		4.5				
Max Green Setting (Gmax), s	5.0	18.0		18.0	5.0	18.0		18.0				
Max Q Clear Time (g_c+I1), s	5.2	4.3		4.0	2.7	3.8		5.3				
Green Ext Time (p_c), s	0.0	1.5		0.5	0.0	1.3		0.3				

Intersection Summary

HCM 6th Ctrl Delay	13.3
HCM 6th LOS	B

Notes

Unsignalized Delay for [WBR] is excluded from calculations of the approach delay and intersection delay.

HCM 6th TWSC
2: Stanton Ave & Sydney Way

04/10/2023

Intersection						
Int Delay, s/veh	4.8					
Movement	WBL	WBR	NBT	NBR	SBL	SBT
Lane Configurations						
Traffic Vol, veh/h	66	18	25	50	44	39
Future Vol, veh/h	66	18	25	50	44	39
Conflicting Peds, #/hr	0	0	0	0	0	0
Sign Control	Stop	Stop	Free	Free	Free	Free
RT Channelized	-	None	-	None	-	None
Storage Length	0	-	-	-	-	-
Veh in Median Storage, #	0	-	0	-	-	0
Grade, %	0	-	0	-	-	0
Peak Hour Factor	95	95	95	95	95	95
Heavy Vehicles, %	2	2	2	2	2	2
Mvmt Flow	69	19	26	53	46	41

Major/Minor	Minor1	Major1	Major2			
Conflicting Flow All	186	53	0	0	79	0
Stage 1	53	-	-	-	-	-
Stage 2	133	-	-	-	-	-
Critical Hdwy	6.42	6.22	-	-	4.12	-
Critical Hdwy Stg 1	5.42	-	-	-	-	-
Critical Hdwy Stg 2	5.42	-	-	-	-	-
Follow-up Hdwy	3.518	3.318	-	-	2.218	-
Pot Cap-1 Maneuver	803	1014	-	-	1519	-
Stage 1	970	-	-	-	-	-
Stage 2	893	-	-	-	-	-
Platoon blocked, %			-	-		-
Mov Cap-1 Maneuver	778	1014	-	-	1519	-
Mov Cap-2 Maneuver	778	-	-	-	-	-
Stage 1	970	-	-	-	-	-
Stage 2	865	-	-	-	-	-

Approach	WB	NB	SB
HCM Control Delay, s	9.9	0	3.9
HCM LOS	A		

Minor Lane/Major Mvmt	NBT	NBRWBLn1	SBL	SBT
Capacity (veh/h)	-	-	819	1519
HCM Lane V/C Ratio	-	-	0.108	0.03
HCM Control Delay (s)	-	-	9.9	7.4
HCM Lane LOS	-	-	A	A
HCM 95th %tile Q(veh)	-	-	0.4	0.1

HCM 6th TWSC
 3: Project Access & Sydney Way

04/10/2023

Intersection						
Int Delay, s/veh	0					
Movement	EBT	EBR	WBL	WBT	NBL	NBR
Lane Configurations	↑			↑	↑	
Traffic Vol, veh/h	97	0	0	84	0	0
Future Vol, veh/h	97	0	0	84	0	0
Conflicting Peds, #/hr	0	0	0	0	0	0
Sign Control	Free	Free	Free	Free	Stop	Stop
RT Channelized	-	None	-	None	-	None
Storage Length	-	-	-	-	0	-
Veh in Median Storage, #	0	-	-	0	0	-
Grade, %	0	-	-	0	0	-
Peak Hour Factor	95	95	95	95	95	95
Heavy Vehicles, %	2	2	2	2	2	2
Mvmt Flow	102	0	0	88	0	0

Major/Minor	Major1	Major2	Minor1		
Conflicting Flow All	0	-	-	-	190 102
Stage 1	-	-	-	-	102 -
Stage 2	-	-	-	-	88 -
Critical Hdwy	-	-	-	-	6.42 6.22
Critical Hdwy Stg 1	-	-	-	-	5.42 -
Critical Hdwy Stg 2	-	-	-	-	5.42 -
Follow-up Hdwy	-	-	-	-	3.518 3.318
Pot Cap-1 Maneuver	-	0	0	-	799 953
Stage 1	-	0	0	-	922 -
Stage 2	-	0	0	-	935 -
Platoon blocked, %	-	-	-	-	-
Mov Cap-1 Maneuver	-	-	-	-	799 953
Mov Cap-2 Maneuver	-	-	-	-	799 -
Stage 1	-	-	-	-	922 -
Stage 2	-	-	-	-	935 -

Approach	EB	WB	NB
HCM Control Delay, s	0	0	0
HCM LOS			A

Minor Lane/Major Mvmt	NBLn1	EBT	WBT
Capacity (veh/h)	-	-	-
HCM Lane V/C Ratio	-	-	-
HCM Control Delay (s)	0	-	-
HCM Lane LOS	A	-	-
HCM 95th %tile Q(veh)	-	-	-

HCM 6th TWSC
4: Carlton Ave & Keith Ave

04/10/2023

Intersection						
Int Delay, s/veh	3.1					
Movement	WBL	WBR	NBT	NBR	SBL	SBT
Lane Configurations						
Traffic Vol, veh/h	22	9	29	15	12	30
Future Vol, veh/h	22	9	29	15	12	30
Conflicting Peds, #/hr	0	0	0	0	0	0
Sign Control	Stop	Stop	Free	Free	Free	Free
RT Channelized	-	None	-	None	-	None
Storage Length	0	-	-	-	-	-
Veh in Median Storage, #	0	-	0	-	-	0
Grade, %	0	-	0	-	-	0
Peak Hour Factor	95	95	95	95	95	95
Heavy Vehicles, %	2	2	2	2	2	2
Mvmt Flow	23	9	31	16	13	32

Major/Minor	Minor1	Major1	Major2		
Conflicting Flow All	97	39	0	0	47
Stage 1	39	-	-	-	-
Stage 2	58	-	-	-	-
Critical Hdwy	6.42	6.22	-	-	4.12
Critical Hdwy Stg 1	5.42	-	-	-	-
Critical Hdwy Stg 2	5.42	-	-	-	-
Follow-up Hdwy	3.518	3.318	-	-	2.218
Pot Cap-1 Maneuver	902	1033	-	-	1560
Stage 1	983	-	-	-	-
Stage 2	965	-	-	-	-
Platoon blocked, %			-	-	-
Mov Cap-1 Maneuver	895	1033	-	-	1560
Mov Cap-2 Maneuver	895	-	-	-	-
Stage 1	983	-	-	-	-
Stage 2	957	-	-	-	-

Approach	WB	NB	SB
HCM Control Delay, s	9	0	2.1
HCM LOS	A		

Minor Lane/Major Mvmt	NBT	NBRWBLn1	SBL	SBT
Capacity (veh/h)	-	-	931	1560
HCM Lane V/C Ratio	-	-	0.035	0.008
HCM Control Delay (s)	-	-	9	7.3
HCM Lane LOS	-	-	A	A
HCM 95th %tile Q(veh)	-	-	0.1	0

HCM 6th Signalized Intersection Summary

1: Lake Chabot Road & Sydney Way/Seven Hills Road

04/10/2023

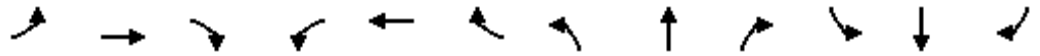

Movement	EBL	EBT	EBR	WBL	WBT	WBR	NBL	NBT	NBR	SBL	SBT	SBR
Lane Configurations		↔	↔		↔	↔	↔	↕	↕	↔	↕	↕
Traffic Volume (veh/h)	10	38	23	23	45	139	30	293	29	187	308	9
Future Volume (veh/h)	10	38	23	23	45	139	30	293	29	187	308	9
Initial Q (Qb), veh	0	0	0	0	0	0	0	0	0	0	0	0
Ped-Bike Adj(A_pbT)	1.00		1.00	1.00		1.00	1.00		1.00	1.00		1.00
Parking Bus, Adj	1.00	1.00	1.00	1.00	1.00	1.00	1.00	1.00	1.00	1.00	1.00	1.00
Work Zone On Approach		No			No			No			No	
Adj Sat Flow, veh/h/ln	1870	1870	1870	1870	1870	1870	1870	1870	1870	1870	1870	1870
Adj Flow Rate, veh/h	11	40	24	24	47	0	32	308	31	197	324	9
Peak Hour Factor	0.95	0.95	0.95	0.95	0.95	0.95	0.95	0.95	0.95	0.95	0.95	0.95
Percent Heavy Veh, %	2	2	2	2	2	2	2	2	2	2	2	2
Cap, veh/h	133	153	158	160	121		66	1449	145	220	1872	52
Arrive On Green	0.10	0.10	0.10	0.10	0.10	0.00	0.04	0.44	0.44	0.12	0.53	0.53
Sat Flow, veh/h	254	1533	1585	416	1212	1585	1781	3263	326	1781	3532	98
Grp Volume(v), veh/h	51	0	24	71	0	0	32	167	172	197	163	170
Grp Sat Flow(s),veh/h/ln	1787	0	1585	1627	0	1585	1781	1777	1812	1781	1777	1853
Q Serve(g_s), s	0.0	0.0	0.6	0.7	0.0	0.0	0.7	2.3	2.4	4.4	1.9	1.9
Cycle Q Clear(g_c), s	1.0	0.0	0.6	1.7	0.0	0.0	0.7	2.3	2.4	4.4	1.9	1.9
Prop In Lane	0.22		1.00	0.34		1.00	1.00		0.18	1.00		0.05
Lane Grp Cap(c), veh/h	286	0	158	281	0		66	789	805	220	942	982
V/C Ratio(X)	0.18	0.00	0.15	0.25	0.00		0.48	0.21	0.21	0.90	0.17	0.17
Avail Cap(c_a), veh/h	882	0	704	849	0		220	789	805	220	942	982
HCM Platoon Ratio	1.00	1.00	1.00	1.00	1.00	1.00	1.00	1.00	1.00	1.00	1.00	1.00
Upstream Filter(I)	1.00	0.00	1.00	1.00	0.00	0.00	1.00	1.00	1.00	1.00	1.00	1.00
Uniform Delay (d), s/veh	16.9	0.0	16.7	17.2	0.0	0.0	19.1	6.9	6.9	17.5	4.9	4.9
Incr Delay (d2), s/veh	0.3	0.0	0.4	0.5	0.0	0.0	5.3	0.6	0.6	34.3	0.4	0.4
Initial Q Delay(d3),s/veh	0.0	0.0	0.0	0.0	0.0	0.0	0.0	0.0	0.0	0.0	0.0	0.0
%ile BackOfQ(50%),veh/ln	0.4	0.0	0.2	0.6	0.0	0.0	0.4	0.8	0.8	3.6	0.5	0.6
Unsig. Movement Delay, s/veh												
LnGrp Delay(d),s/veh	17.2	0.0	17.1	17.6	0.0	0.0	24.4	7.5	7.5	51.8	5.3	5.3
LnGrp LOS	B	A	B	B	A		C	A	A	D	A	A
Approach Vol, veh/h		75			71			371			530	
Approach Delay, s/veh		17.2			17.6			9.0			22.6	
Approach LOS		B			B			A			C	
Timer - Assigned Phs	1	2		4	5	6		8				
Phs Duration (G+Y+Rc), s	9.5	22.5		8.5	6.0	26.0		8.5				
Change Period (Y+Rc), s	4.5	4.5		4.5	4.5	4.5		4.5				
Max Green Setting (Gmax), s	5.0	18.0		18.0	5.0	18.0		18.0				
Max Q Clear Time (g_c+I1), s	6.4	4.4		3.0	2.7	3.9		3.7				
Green Ext Time (p_c), s	0.0	1.6		0.2	0.0	1.6		0.2				

Intersection Summary

HCM 6th Ctrl Delay	17.0
HCM 6th LOS	B

Notes

Unsignalized Delay for [WBR] is excluded from calculations of the approach delay and intersection delay.

HCM 6th TWSC
2: Stanton Ave & Sydney Way

04/10/2023

Intersection						
Int Delay, s/veh	4					
Movement	WBL	WBR	NBT	NBR	SBL	SBT
Lane Configurations						
Traffic Vol, veh/h	34	31	37	43	22	22
Future Vol, veh/h	34	31	37	43	22	22
Conflicting Peds, #/hr	0	0	0	0	0	0
Sign Control	Stop	Stop	Free	Free	Free	Free
RT Channelized	-	None	-	None	-	None
Storage Length	0	-	-	-	-	-
Veh in Median Storage, #	0	-	0	-	-	0
Grade, %	0	-	0	-	-	0
Peak Hour Factor	95	95	95	95	95	95
Heavy Vehicles, %	2	2	2	2	2	2
Mvmt Flow	36	33	39	45	23	23

Major/Minor	Minor1	Major1	Major2		
Conflicting Flow All	131	62	0	0	84
Stage 1	62	-	-	-	-
Stage 2	69	-	-	-	-
Critical Hdwy	6.42	6.22	-	-	4.12
Critical Hdwy Stg 1	5.42	-	-	-	-
Critical Hdwy Stg 2	5.42	-	-	-	-
Follow-up Hdwy	3.518	3.318	-	-	2.218
Pot Cap-1 Maneuver	863	1003	-	-	1513
Stage 1	961	-	-	-	-
Stage 2	954	-	-	-	-
Platoon blocked, %			-	-	-
Mov Cap-1 Maneuver	850	1003	-	-	1513
Mov Cap-2 Maneuver	850	-	-	-	-
Stage 1	961	-	-	-	-
Stage 2	940	-	-	-	-

Approach	WB	NB	SB
HCM Control Delay, s	9.2	0	3.7
HCM LOS	A		

Minor Lane/Major Mvmt	NBT	NBRWBLn1	SBL	SBT
Capacity (veh/h)	-	-	917	1513
HCM Lane V/C Ratio	-	-	0.075	0.015
HCM Control Delay (s)	-	-	9.2	7.4
HCM Lane LOS	-	-	A	A
HCM 95th %tile Q(veh)	-	-	0.2	0

HCM 6th TWSC
3: Project Access & Sydney Way

04/10/2023

Intersection						
Int Delay, s/veh	0					
Movement	EBT	EBR	WBL	WBT	NBL	NBR
Lane Configurations	↑			↑	↑	
Traffic Vol, veh/h	68	0	0	68	0	0
Future Vol, veh/h	68	0	0	68	0	0
Conflicting Peds, #/hr	0	0	0	0	0	0
Sign Control	Free	Free	Free	Free	Stop	Stop
RT Channelized	-	None	-	None	-	None
Storage Length	-	-	-	-	0	-
Veh in Median Storage, #	0	-	-	0	0	-
Grade, %	0	-	-	0	0	-
Peak Hour Factor	95	95	95	95	95	95
Heavy Vehicles, %	2	2	2	2	2	2
Mvmt Flow	72	0	0	72	0	0

Major/Minor	Major1	Major2	Minor1		
Conflicting Flow All	0	-	-	-	144 72
Stage 1	-	-	-	-	72 -
Stage 2	-	-	-	-	72 -
Critical Hdwy	-	-	-	-	6.42 6.22
Critical Hdwy Stg 1	-	-	-	-	5.42 -
Critical Hdwy Stg 2	-	-	-	-	5.42 -
Follow-up Hdwy	-	-	-	-	3.518 3.318
Pot Cap-1 Maneuver	-	0	0	-	849 990
Stage 1	-	0	0	-	951 -
Stage 2	-	0	0	-	951 -
Platoon blocked, %	-	-	-	-	-
Mov Cap-1 Maneuver	-	-	-	-	849 990
Mov Cap-2 Maneuver	-	-	-	-	849 -
Stage 1	-	-	-	-	951 -
Stage 2	-	-	-	-	951 -

Approach	EB	WB	NB
HCM Control Delay, s	0	0	0
HCM LOS			A

Minor Lane/Major Mvmt	NBLn1	EBT	WBT
Capacity (veh/h)	-	-	-
HCM Lane V/C Ratio	-	-	-
HCM Control Delay (s)	0	-	-
HCM Lane LOS	A	-	-
HCM 95th %tile Q(veh)	-	-	-

HCM 6th TWSC
4: Carlton Ave & Keith Ave

04/10/2023

Intersection						
Int Delay, s/veh	2.6					
Movement	WBL	WBR	NBT	NBR	SBL	SBT
Lane Configurations						
Traffic Vol, veh/h	8	12	36	10	9	20
Future Vol, veh/h	8	12	36	10	9	20
Conflicting Peds, #/hr	0	0	0	0	0	0
Sign Control	Stop	Stop	Free	Free	Free	Free
RT Channelized	-	None	-	None	-	None
Storage Length	0	-	-	-	-	-
Veh in Median Storage, #	0	-	0	-	-	0
Grade, %	0	-	0	-	-	0
Peak Hour Factor	95	95	95	95	95	95
Heavy Vehicles, %	2	2	2	2	2	2
Mvmt Flow	8	13	38	11	9	21

Major/Minor	Minor1	Major1	Major2		
Conflicting Flow All	83	44	0	0	49
Stage 1	44	-	-	-	-
Stage 2	39	-	-	-	-
Critical Hdwy	6.42	6.22	-	-	4.12
Critical Hdwy Stg 1	5.42	-	-	-	-
Critical Hdwy Stg 2	5.42	-	-	-	-
Follow-up Hdwy	3.518	3.318	-	-	2.218
Pot Cap-1 Maneuver	919	1026	-	-	1558
Stage 1	978	-	-	-	-
Stage 2	983	-	-	-	-
Platoon blocked, %			-	-	-
Mov Cap-1 Maneuver	913	1026	-	-	1558
Mov Cap-2 Maneuver	913	-	-	-	-
Stage 1	978	-	-	-	-
Stage 2	977	-	-	-	-

Approach	WB	NB	SB
HCM Control Delay, s	8.8	0	2.3
HCM LOS	A		

Minor Lane/Major Mvmt	NBT	NBRWBLn1	SBL	SBT
Capacity (veh/h)	-	-	978	1558
HCM Lane V/C Ratio	-	-	0.022	0.006
HCM Control Delay (s)	-	-	8.8	7.3
HCM Lane LOS	-	-	A	A
HCM 95th %tile Q(veh)	-	-	0.1	0

HCM 6th Signalized Intersection Summary

1: Lake Chabot Road & Sydney Way/Seven Hills Road

04/10/2023

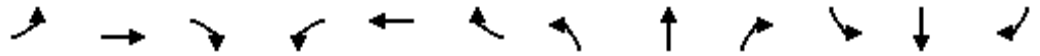

Movement	EBL	EBT	EBR	WBL	WBT	WBR	NBL	NBT	NBR	SBL	SBT	SBR
Lane Configurations		↕	↗		↕	↗	↗	↕↕		↗	↕↕	
Traffic Volume (veh/h)	12	85	51	47	44	280	32	273	31	134	270	6
Future Volume (veh/h)	12	85	51	47	44	280	32	273	31	134	270	6
Initial Q (Qb), veh	0	0	0	0	0	0	0	0	0	0	0	0
Ped-Bike Adj(A_pbT)	1.00		1.00	1.00		1.00	1.00		1.00	1.00		1.00
Parking Bus, Adj	1.00	1.00	1.00	1.00	1.00	1.00	1.00	1.00	1.00	1.00	1.00	1.00
Work Zone On Approach		No			No			No			No	
Adj Sat Flow, veh/h/ln	1870	1870	1870	1870	1870	1870	1870	1870	1870	1870	1870	1870
Adj Flow Rate, veh/h	13	89	54	49	46	0	34	287	33	141	284	6
Peak Hour Factor	0.95	0.95	0.95	0.95	0.95	0.95	0.95	0.95	0.95	0.95	0.95	0.95
Percent Heavy Veh, %	2	2	2	2	2	2	2	2	2	2	2	2
Cap, veh/h	116	221	206	194	102		70	1414	161	179	1784	38
Arrive On Green	0.13	0.13	0.13	0.13	0.13	0.00	0.04	0.44	0.44	0.10	0.50	0.50
Sat Flow, veh/h	133	1703	1585	470	784	1585	1781	3215	366	1781	3559	75
Grp Volume(v), veh/h	102	0	54	95	0	0	34	157	163	141	142	148
Grp Sat Flow(s),veh/h/ln	1836	0	1585	1254	0	1585	1781	1777	1804	1781	1777	1857
Q Serve(g_s), s	0.0	0.0	1.3	1.3	0.0	0.0	0.8	2.2	2.3	3.2	1.8	1.8
Cycle Q Clear(g_c), s	2.1	0.0	1.3	3.3	0.0	0.0	0.8	2.2	2.3	3.2	1.8	1.8
Prop In Lane	0.13		1.00	0.52		1.00	1.00		0.20	1.00		0.04
Lane Grp Cap(c), veh/h	337	0	206	296	0		70	781	793	179	891	931
V/C Ratio(X)	0.30	0.00	0.26	0.32	0.00		0.49	0.20	0.20	0.79	0.16	0.16
Avail Cap(c_a), veh/h	891	0	697	757	0		218	781	793	218	891	931
HCM Platoon Ratio	1.00	1.00	1.00	1.00	1.00	1.00	1.00	1.00	1.00	1.00	1.00	1.00
Upstream Filter(I)	1.00	0.00	1.00	1.00	0.00	0.00	1.00	1.00	1.00	1.00	1.00	1.00
Uniform Delay (d), s/veh	16.4	0.0	16.0	16.9	0.0	0.0	19.3	7.1	7.1	18.0	5.5	5.5
Incr Delay (d2), s/veh	0.5	0.0	0.7	0.6	0.0	0.0	5.2	0.6	0.6	14.3	0.4	0.4
Initial Q Delay(d3),s/veh	0.0	0.0	0.0	0.0	0.0	0.0	0.0	0.0	0.0	0.0	0.0	0.0
%ile BackOfQ(50%),veh/ln	0.8	0.0	0.4	0.8	0.0	0.0	0.4	0.7	0.8	1.8	0.5	0.5
Unsig. Movement Delay, s/veh												
LnGrp Delay(d),s/veh	16.9	0.0	16.7	17.5	0.0	0.0	24.4	7.6	7.6	32.3	5.9	5.9
LnGrp LOS	B	A	B	B	A		C	A	A	C	A	A
Approach Vol, veh/h		156			95			354			431	
Approach Delay, s/veh		16.8			17.5			9.3			14.5	
Approach LOS		B			B			A			B	
Timer - Assigned Phs	1	2		4	5	6		8				
Phs Duration (G+Y+Rc), s	8.6	22.5		9.8	6.1	25.0		9.8				
Change Period (Y+Rc), s	4.5	4.5		4.5	4.5	4.5		4.5				
Max Green Setting (Gmax), s	5.0	18.0		18.0	5.0	18.0		18.0				
Max Q Clear Time (g_c+I1), s	5.2	4.3		4.1	2.8	3.8		5.3				
Green Ext Time (p_c), s	0.0	1.5		0.5	0.0	1.3		0.3				

Intersection Summary

HCM 6th Ctrl Delay	13.4
HCM 6th LOS	B

Notes

Unsignalized Delay for [WBR] is excluded from calculations of the approach delay and intersection delay.

HCM 6th TWSC
2: Stanton Ave & Sydney Way

04/10/2023

Intersection						
Int Delay, s/veh	4.9					
Movement	WBL	WBR	NBT	NBR	SBL	SBT
Lane Configurations						
Traffic Vol, veh/h	69	20	25	52	45	39
Future Vol, veh/h	69	20	25	52	45	39
Conflicting Peds, #/hr	0	0	0	0	0	0
Sign Control	Stop	Stop	Free	Free	Free	Free
RT Channelized	-	None	-	None	-	None
Storage Length	0	-	-	-	-	-
Veh in Median Storage, #	0	-	0	-	-	0
Grade, %	0	-	0	-	-	0
Peak Hour Factor	95	95	95	95	95	95
Heavy Vehicles, %	2	2	2	2	2	2
Mvmt Flow	73	21	26	55	47	41

Major/Minor	Minor1	Major1	Major2		
Conflicting Flow All	189	54	0	0	81
Stage 1	54	-	-	-	-
Stage 2	135	-	-	-	-
Critical Hdwy	6.42	6.22	-	-	4.12
Critical Hdwy Stg 1	5.42	-	-	-	-
Critical Hdwy Stg 2	5.42	-	-	-	-
Follow-up Hdwy	3.518	3.318	-	-	2.218
Pot Cap-1 Maneuver	800	1013	-	-	1517
Stage 1	969	-	-	-	-
Stage 2	891	-	-	-	-
Platoon blocked, %			-	-	-
Mov Cap-1 Maneuver	774	1013	-	-	1517
Mov Cap-2 Maneuver	774	-	-	-	-
Stage 1	969	-	-	-	-
Stage 2	862	-	-	-	-

Approach	WB	NB	SB
HCM Control Delay, s	10	0	4
HCM LOS	B		

Minor Lane/Major Mvmt	NBT	NBRWBLn1	SBL	SBT
Capacity (veh/h)	-	-	817	1517
HCM Lane V/C Ratio	-	-	0.115	0.031
HCM Control Delay (s)	-	-	10	7.5
HCM Lane LOS	-	-	B	A
HCM 95th %tile Q(veh)	-	-	0.4	0.1

HCM 6th TWSC
3: Project Access & Sydney Way

04/10/2023

Intersection						
Int Delay, s/veh	0.5					
Movement	EBT	EBR	WBL	WBT	NBL	NBR
Lane Configurations	↑			↑	↑	
Traffic Vol, veh/h	97	2	2	84	5	4
Future Vol, veh/h	97	2	2	84	5	4
Conflicting Peds, #/hr	0	0	0	0	0	0
Sign Control	Free	Free	Free	Free	Stop	Stop
RT Channelized	-	None	-	None	-	None
Storage Length	-	-	-	-	0	-
Veh in Median Storage, #	0	-	-	0	0	-
Grade, %	0	-	-	0	0	-
Peak Hour Factor	95	95	95	95	95	95
Heavy Vehicles, %	2	2	2	2	2	2
Mvmt Flow	102	2	2	88	5	4

Major/Minor	Major1	Major2	Minor1		
Conflicting Flow All	0	0	104	0	195
Stage 1	-	-	-	-	103
Stage 2	-	-	-	-	92
Critical Hdwy	-	-	4.12	-	6.42
Critical Hdwy Stg 1	-	-	-	-	5.42
Critical Hdwy Stg 2	-	-	-	-	5.42
Follow-up Hdwy	-	-	2.218	-	3.518
Pot Cap-1 Maneuver	-	-	1488	-	794
Stage 1	-	-	-	-	921
Stage 2	-	-	-	-	932
Platoon blocked, %	-	-	-	-	-
Mov Cap-1 Maneuver	-	-	1488	-	793
Mov Cap-2 Maneuver	-	-	-	-	793
Stage 1	-	-	-	-	921
Stage 2	-	-	-	-	931

Approach	EB	WB	NB
HCM Control Delay, s	0	0.2	9.2
HCM LOS			A

Minor Lane/Major Mvmt	NBLn1	EBT	EBR	WBL	WBT
Capacity (veh/h)	857	-	-	1488	-
HCM Lane V/C Ratio	0.011	-	-	0.001	-
HCM Control Delay (s)	9.2	-	-	7.4	-
HCM Lane LOS	A	-	-	A	-
HCM 95th %tile Q(veh)	0	-	-	0	-

HCM 6th TWSC
4: Carlton Ave & Severini Lane/Keith Ave

04/10/2023

Intersection												
Int Delay, s/veh	3.7											
Movement	EBL	EBT	EBR	WBL	WBT	WBR	NBL	NBT	NBR	SBL	SBT	SBR
Lane Configurations		↕			↕			↕			↕	
Traffic Vol, veh/h	2	3	3	22	2	9	2	29	15	12	30	1
Future Vol, veh/h	2	3	3	22	2	9	2	29	15	12	30	1
Conflicting Peds, #/hr	0	0	0	0	0	0	0	0	0	0	0	0
Sign Control	Stop	Stop	Stop	Stop	Stop	Stop	Free	Free	Free	Free	Free	Free
RT Channelized	-	-	None	-	-	None	-	-	None	-	-	None
Storage Length	-	-	-	-	-	-	-	-	-	-	-	-
Veh in Median Storage, #	-	0	-	-	0	-	-	0	-	-	0	-
Grade, %	-	0	-	-	0	-	-	0	-	-	0	-
Peak Hour Factor	95	95	95	95	95	95	95	95	95	95	95	95
Heavy Vehicles, %	2	2	2	2	2	2	2	2	2	2	2	2
Mvmt Flow	2	3	3	23	2	9	2	31	16	13	32	1

Major/Minor	Minor2		Minor1		Major1			Major2				
Conflicting Flow All	108	110	33	105	102	39	33	0	0	47	0	0
Stage 1	59	59	-	43	43	-	-	-	-	-	-	-
Stage 2	49	51	-	62	59	-	-	-	-	-	-	-
Critical Hdwy	7.12	6.52	6.22	7.12	6.52	6.22	4.12	-	-	4.12	-	-
Critical Hdwy Stg 1	6.12	5.52	-	6.12	5.52	-	-	-	-	-	-	-
Critical Hdwy Stg 2	6.12	5.52	-	6.12	5.52	-	-	-	-	-	-	-
Follow-up Hdwy	3.518	4.018	3.318	3.518	4.018	3.318	2.218	-	-	2.218	-	-
Pot Cap-1 Maneuver	871	780	1041	875	788	1033	1579	-	-	1560	-	-
Stage 1	953	846	-	971	859	-	-	-	-	-	-	-
Stage 2	964	852	-	949	846	-	-	-	-	-	-	-
Platoon blocked, %								-	-	-	-	-
Mov Cap-1 Maneuver	855	773	1041	864	781	1033	1579	-	-	1560	-	-
Mov Cap-2 Maneuver	855	773	-	864	781	-	-	-	-	-	-	-
Stage 1	952	839	-	970	858	-	-	-	-	-	-	-
Stage 2	952	851	-	935	839	-	-	-	-	-	-	-

Approach	EB		WB		NB		SB	
HCM Control Delay, s	9.1		9.2		0.3		2	
HCM LOS	A		A					

Minor Lane/Major Mvmt	NBL	NBT	NBR	EBLn1WBLn1	SBL	SBT	SBR
Capacity (veh/h)	1579	-	-	879	898	1560	-
HCM Lane V/C Ratio	0.001	-	-	0.01	0.039	0.008	-
HCM Control Delay (s)	7.3	0	-	9.1	9.2	7.3	0
HCM Lane LOS	A	A	-	A	A	A	A
HCM 95th %tile Q(veh)	0	-	-	0	0.1	0	-

HCM 6th Signalized Intersection Summary

1: Lake Chabot Road & Sydney Way/Seven Hills Road

04/10/2023

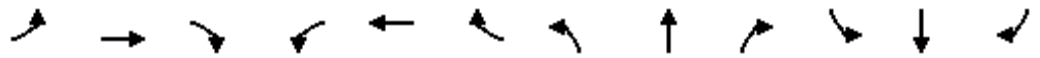

Movement	EBL	EBT	EBR	WBL	WBT	WBR	NBL	NBT	NBR	SBL	SBT	SBR
Lane Configurations		↕	↗		↕	↗	↗	↕↕		↗	↕↕	
Traffic Volume (veh/h)	11	38	24	23	45	139	31	293	29	187	308	9
Future Volume (veh/h)	11	38	24	23	45	139	31	293	29	187	308	9
Initial Q (Qb), veh	0	0	0	0	0	0	0	0	0	0	0	0
Ped-Bike Adj(A_pbT)	1.00		1.00	1.00		1.00	1.00		1.00	1.00		1.00
Parking Bus, Adj	1.00	1.00	1.00	1.00	1.00	1.00	1.00	1.00	1.00	1.00	1.00	1.00
Work Zone On Approach		No			No			No			No	
Adj Sat Flow, veh/h/ln	1870	1870	1870	1870	1870	1870	1870	1870	1870	1870	1870	1870
Adj Flow Rate, veh/h	12	40	25	24	47	0	33	308	31	197	324	9
Peak Hour Factor	0.95	0.95	0.95	0.95	0.95	0.95	0.95	0.95	0.95	0.95	0.95	0.95
Percent Heavy Veh, %	2	2	2	2	2	2	2	2	2	2	2	2
Cap, veh/h	137	151	159	160	121		68	1448	145	220	1868	52
Arrive On Green	0.10	0.10	0.10	0.10	0.10	0.00	0.04	0.44	0.44	0.12	0.53	0.53
Sat Flow, veh/h	274	1507	1585	414	1212	1585	1781	3263	326	1781	3532	98
Grp Volume(v), veh/h	52	0	25	71	0	0	33	167	172	197	163	170
Grp Sat Flow(s),veh/h/ln	1781	0	1585	1626	0	1585	1781	1777	1812	1781	1777	1853
Q Serve(g_s), s	0.0	0.0	0.6	0.7	0.0	0.0	0.7	2.3	2.4	4.4	1.9	1.9
Cycle Q Clear(g_c), s	1.0	0.0	0.6	1.7	0.0	0.0	0.7	2.3	2.4	4.4	1.9	1.9
Prop In Lane	0.23		1.00	0.34		1.00	1.00		0.18	1.00		0.05
Lane Grp Cap(c), veh/h	287	0	159	281	0		68	789	804	220	940	980
V/C Ratio(X)	0.18	0.00	0.16	0.25	0.00		0.48	0.21	0.21	0.90	0.17	0.17
Avail Cap(c_a), veh/h	879	0	703	848	0		220	789	804	220	940	980
HCM Platoon Ratio	1.00	1.00	1.00	1.00	1.00	1.00	1.00	1.00	1.00	1.00	1.00	1.00
Upstream Filter(I)	1.00	0.00	1.00	1.00	0.00	0.00	1.00	1.00	1.00	1.00	1.00	1.00
Uniform Delay (d), s/veh	16.9	0.0	16.7	17.2	0.0	0.0	19.1	6.9	6.9	17.5	5.0	5.0
Incr Delay (d2), s/veh	0.3	0.0	0.5	0.5	0.0	0.0	5.2	0.6	0.6	34.4	0.4	0.4
Initial Q Delay(d3),s/veh	0.0	0.0	0.0	0.0	0.0	0.0	0.0	0.0	0.0	0.0	0.0	0.0
%ile BackOfQ(50%),veh/ln	0.4	0.0	0.2	0.6	0.0	0.0	0.4	0.8	0.8	3.6	0.5	0.6
Unsig. Movement Delay, s/veh												
LnGrp Delay(d),s/veh	17.2	0.0	17.1	17.6	0.0	0.0	24.3	7.5	7.5	51.9	5.4	5.3
LnGrp LOS	B	A	B	B	A		C	A	A	D	A	A
Approach Vol, veh/h		77			71			372			530	
Approach Delay, s/veh		17.2			17.6			9.0			22.7	
Approach LOS		B			B			A			C	
Timer - Assigned Phs	1	2		4	5	6		8				
Phs Duration (G+Y+Rc), s	9.5	22.5		8.6	6.1	25.9		8.6				
Change Period (Y+Rc), s	4.5	4.5		4.5	4.5	4.5		4.5				
Max Green Setting (Gmax), s	5.0	18.0		18.0	5.0	18.0		18.0				
Max Q Clear Time (g_c+I1), s	6.4	4.4		3.0	2.7	3.9		3.7				
Green Ext Time (p_c), s	0.0	1.6		0.2	0.0	1.6		0.2				

Intersection Summary

HCM 6th Ctrl Delay	17.1
HCM 6th LOS	B

Notes

Unsignalized Delay for [WBR] is excluded from calculations of the approach delay and intersection delay.

HCM 6th TWSC
2: Stanton Ave & Sydney Way

04/10/2023

Intersection						
Int Delay, s/veh	4.1					
Movement	WBL	WBR	NBT	NBR	SBL	SBT
Lane Configurations						
Traffic Vol, veh/h	36	32	37	44	23	22
Future Vol, veh/h	36	32	37	44	23	22
Conflicting Peds, #/hr	0	0	0	0	0	0
Sign Control	Stop	Stop	Free	Free	Free	Free
RT Channelized	-	None	-	None	-	None
Storage Length	0	-	-	-	-	-
Veh in Median Storage, #	0	-	0	-	-	0
Grade, %	0	-	0	-	-	0
Peak Hour Factor	95	95	95	95	95	95
Heavy Vehicles, %	2	2	2	2	2	2
Mvmt Flow	38	34	39	46	24	23

Major/Minor	Minor1	Major1	Major2		
Conflicting Flow All	133	62	0	0	85
Stage 1	62	-	-	-	-
Stage 2	71	-	-	-	-
Critical Hdwy	6.42	6.22	-	-	4.12
Critical Hdwy Stg 1	5.42	-	-	-	-
Critical Hdwy Stg 2	5.42	-	-	-	-
Follow-up Hdwy	3.518	3.318	-	-	2.218
Pot Cap-1 Maneuver	861	1003	-	-	1512
Stage 1	961	-	-	-	-
Stage 2	952	-	-	-	-
Platoon blocked, %			-	-	-
Mov Cap-1 Maneuver	847	1003	-	-	1512
Mov Cap-2 Maneuver	847	-	-	-	-
Stage 1	961	-	-	-	-
Stage 2	937	-	-	-	-

Approach	WB	NB	SB
HCM Control Delay, s	9.3	0	3.8
HCM LOS	A		

Minor Lane/Major Mvmt	NBT	NBRWBLn1	SBL	SBT
Capacity (veh/h)	-	-	914	1512
HCM Lane V/C Ratio	-	-	0.078	0.016
HCM Control Delay (s)	-	-	9.3	7.4
HCM Lane LOS	-	-	A	A
HCM 95th %tile Q(veh)	-	-	0.3	0

HCM 6th TWSC
3: Project Access & Sydney Way

04/10/2023

Intersection						
Int Delay, s/veh	0.4					
Movement	EBT	EBR	WBL	WBT	NBL	NBR
Lane Configurations	↑			↑	↑	
Traffic Vol, veh/h	68	2	1	68	3	2
Future Vol, veh/h	68	2	1	68	3	2
Conflicting Peds, #/hr	0	0	0	0	0	0
Sign Control	Free	Free	Free	Free	Stop	Stop
RT Channelized	-	None	-	None	-	None
Storage Length	-	-	-	-	0	-
Veh in Median Storage, #	0	-	-	0	0	-
Grade, %	0	-	-	0	0	-
Peak Hour Factor	95	95	95	95	95	95
Heavy Vehicles, %	2	2	2	2	2	2
Mvmt Flow	72	2	1	72	3	2

Major/Minor	Major1	Major2	Minor1		
Conflicting Flow All	0	0	74	0	147 73
Stage 1	-	-	-	-	73 -
Stage 2	-	-	-	-	74 -
Critical Hdwy	-	-	4.12	-	6.42 6.22
Critical Hdwy Stg 1	-	-	-	-	5.42 -
Critical Hdwy Stg 2	-	-	-	-	5.42 -
Follow-up Hdwy	-	-	2.218	-	3.518 3.318
Pot Cap-1 Maneuver	-	-	1526	-	845 989
Stage 1	-	-	-	-	950 -
Stage 2	-	-	-	-	949 -
Platoon blocked, %	-	-	-	-	-
Mov Cap-1 Maneuver	-	-	1526	-	844 989
Mov Cap-2 Maneuver	-	-	-	-	844 -
Stage 1	-	-	-	-	950 -
Stage 2	-	-	-	-	948 -

Approach	EB	WB	NB
HCM Control Delay, s	0	0.1	9
HCM LOS			A

Minor Lane/Major Mvmt	NBLn1	EBT	EBR	WBL	WBT
Capacity (veh/h)	897	-	-	1526	-
HCM Lane V/C Ratio	0.006	-	-	0.001	-
HCM Control Delay (s)	9	-	-	7.4	-
HCM Lane LOS	A	-	-	A	-
HCM 95th %tile Q(veh)	0	-	-	0	-

HCM 6th TWSC
4: Carlton Ave & Severini Lane/Keith Ave

04/10/2023

Intersection												
Int Delay, s/veh	3											
Movement	EBL	EBT	EBR	WBL	WBT	WBR	NBL	NBT	NBR	SBL	SBT	SBR
Lane Configurations		↕			↕			↕			↕	
Traffic Vol, veh/h	1	2	2	8	1	12	1	36	10	9	20	0
Future Vol, veh/h	1	2	2	8	1	12	1	36	10	9	20	0
Conflicting Peds, #/hr	0	0	0	0	0	0	0	0	0	0	0	0
Sign Control	Stop	Stop	Stop	Stop	Stop	Stop	Free	Free	Free	Free	Free	Free
RT Channelized	-	-	None	-	-	None	-	-	None	-	-	None
Storage Length	-	-	-	-	-	-	-	-	-	-	-	-
Veh in Median Storage, #	-	0	-	-	0	-	-	0	-	-	0	-
Grade, %	-	0	-	-	0	-	-	0	-	-	0	-
Peak Hour Factor	95	95	95	95	95	95	95	95	95	95	95	95
Heavy Vehicles, %	2	2	2	2	2	2	2	2	2	2	2	2
Mvmt Flow	1	2	2	8	1	13	1	38	11	9	21	0

Major/Minor	Minor2		Minor1		Major1		Major2					
Conflicting Flow All	92	90	21	87	85	44	21	0	0	49	0	0
Stage 1	39	39	-	46	46	-	-	-	-	-	-	-
Stage 2	53	51	-	41	39	-	-	-	-	-	-	-
Critical Hdwy	7.12	6.52	6.22	7.12	6.52	6.22	4.12	-	-	4.12	-	-
Critical Hdwy Stg 1	6.12	5.52	-	6.12	5.52	-	-	-	-	-	-	-
Critical Hdwy Stg 2	6.12	5.52	-	6.12	5.52	-	-	-	-	-	-	-
Follow-up Hdwy	3.518	4.018	3.318	3.518	4.018	3.318	2.218	-	-	2.218	-	-
Pot Cap-1 Maneuver	892	800	1056	899	805	1026	1595	-	-	1558	-	-
Stage 1	976	862	-	968	857	-	-	-	-	-	-	-
Stage 2	960	852	-	974	862	-	-	-	-	-	-	-
Platoon blocked, %								-	-	-	-	-
Mov Cap-1 Maneuver	875	794	1056	891	799	1026	1595	-	-	1558	-	-
Mov Cap-2 Maneuver	875	794	-	891	799	-	-	-	-	-	-	-
Stage 1	975	857	-	967	856	-	-	-	-	-	-	-
Stage 2	946	851	-	964	857	-	-	-	-	-	-	-

Approach	EB		WB		NB		SB	
HCM Control Delay, s	9		8.8		0.2		2.3	
HCM LOS	A		A					

Minor Lane/Major Mvmt	NBL	NBT	NBR	EBLn1WBLn1	SBL	SBT	SBR
Capacity (veh/h)	1595	-	-	900	958	1558	-
HCM Lane V/C Ratio	0.001	-	-	0.006	0.023	0.006	-
HCM Control Delay (s)	7.3	0	-	9	8.8	7.3	0
HCM Lane LOS	A	A	-	A	A	A	A
HCM 95th %tile Q(veh)	0	-	-	0	0.1	0	-